



HEAVY DUTY ENCODERS & RESOLVERS

- Incremental
- Absolute
- Smartcoder & R-D IC
- Serial Interface

Contact Us! 800-433-3434 USA
Email info@grp6.com

15Hunrtng Ridge Drive
Simsbury, CT 06070

Motortronics®

Advanced Rotary Sensor

Best Suited for High-performance • Heavy-duty Applications



TAMAGAWA SEIKI CO.,LTD.

Contact: GROUP SIX

800-433-3434 USA

email: info@grp6.com

Purchase Source: GROUP SIX (USA)

info@grp6.com 800-433-3434

Fresh air and an abundance of industrious manpower...here is the base of cutting-edge technology.



Tamagawa seiki
Headquarters



〈100 selected pure bodies of water in Japan〉

Sarukura Springs

Sarukura Springs is located about 1 km northwest of Tamagawa Seiki. The water, designated as one of the 100 purest bodies of water in Japan by the Environment Agency, is well-known for its purity. It is more proof that this area is favored with a clean environment.



Encoders & Resolvers

Contents

- Features and Comparison of Encoders/Resolvers 3 • 4
- Digest of Encoders..... 5 • 6
- Specifications of Encoders..... 7 • 8
- Model Designation of Encoders 9 • 10
- Dimensions of Encoders 11 ~ 17
- Serial Signal Receiver IC 18
- Installation of Encoders 19
- Notice in Handling Encoders..... 20
- Digest of Resolvers 21 • 22
- Specifications of Resolvers 23 • 24
- Dimensions of Resolvers 25 • 26
- Smartcoder®
(Resolver to Digital Converter:AU6802N1)..... 27
- Connection of Smartcoder®
(AU6802N1) to Resolvers..... 28
- Installation of Resolvers 29 • 30
- Holders for Resolvers 31
- Notice in Handling Resolvers 32
- Types and Designations of Protective Structure 33
- Conversion Table 34



〈100 selected Avenues in Japan〉

Apple Avenue

A major fire in 1947 reduced the old residential and business section of Iida City Center to ashes. After the fire, apple trees were planted along a burnt mid-town avenue and nurtured devotedly by students of one of the town's junior high schools. Since then this 400 meter row of apple trees, among which are some trees derived from Newton's apple tree, have been proudly cultivated as a symbol of modern Iida City.

Features and Comparison of Encoders/Resolvers

Features of Encoders (for High-performance Applications)

Features

■ High resolution. Small diameter

- Incremental type : 3,000C/T with $\phi 35$ 6,000C/T with $\phi 48$ 8,192C/T with $\phi 60$
- Absolute type : 17 bit (131,072 division, 9.89 sec) with $\phi 35$ provided with multi-turn function.

■ Easy to interface

- Easy to control pulse output of encoders.

■ Fewer wires

(Absolute Type)

- Capable of wire-saving and high-speed data communication through serial transmission. Only 4~6 output wires for a 17 bit encoder.

- Capable of bus connection up to 8 encoders. (Not included in this catalog)

(Incremental Type)

- Output wires are minimized : 14 wires \rightarrow 8 wires

■ Intelligent (Absolute Type)

- Provided with Fail-check function
- Provided with Zero position clear function

■ Compact·Miniaturized (Absolute Type)

- Systems can be compact by modular structure
- Extremely thin – only 18 mm in height

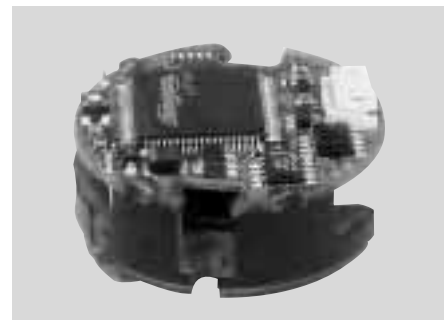

Comparison of encoders

Angular sensor	Encoder	
	Incremental	Absolute
Accuracy of absolute angle	◎ ~ $\pm 60''$	◎ ~ $\pm 80''$
Resolution	~10,000 C/T	17/33bit
Tracking rate	○ 6,000min ⁻¹	○ 6,000min ⁻¹
Structure	○	◎
Heat-resistance	○ -20°C~+85°C	○ -10°C~+85°C
Noise-resistance	◎	◎
Reliability	○	○

◎Excellent ○Satisfactory △Inferior

Features of Resolvers (for Heavy-duty Applications)

Features

- Wide temperature range
 - Operating temperature -55~+155°C
- Robust against demanding environment
 - Vibration 196m/s² {20G}
 - Shock 980m/s² {100G}
 - Humidity Relative humidity 90% Rh or more
- High speed revolution
 - 20,000min⁻¹ {rpm} (Smartsyn[®])
(S-08 : 30,000min⁻¹ {rpm})
 - 30,000min⁻¹ {rpm} (Singlsyn[®])
- High reliability
 - Resolvers have similar structure to electric motors. In particular, our Singlsyn[®] (a kind of resolver) has high reliability because no wire is coiled on its rotor.
 - Free from maintenance because no bearing is used.
- Sensing absolute position and velocity
 - Capable of converting analog output signals of a resolver to digital position signals or velocity signals by connecting the resolver to Smartcoder[®] (Resolver to Digital converter).
 - The position signals are transformed into absolute position output within a range of electrical one cycle.
- Capable of corresponding to multi-polar type
- Compact
 - Realizes smallest mounting space because of its extremely thin dimensions. (S-15 : 16mm)











Comparison of resolvers

Angular sensor	Resolver	
	Singlsyn	Smartsyn
Accuracy of absolute angle	△ ± 30' ~±60'	○ ± 10'
Resolution	1,024×2 / 4,096×2 (2×) 1,024×3 / 4,096×3 (3×) 1,024×4 / 4,096×4 (4×) ※1	1,024 4,096 ※1
Tracking rate	◎ 30,000min ⁻¹	◎ 20,000min ⁻¹
Structure	◎	○
Heat-resistance	◎ -55°C~+155°C	◎ -55°C~+155°C
Noise-resistance	◎	◎
Reliability	◎	◎

※1 Combination with Smartcoder[®]

Absolute Encoders

	Outer dia. (mm)	Inner dia. (mm)	Resolution (bit)	Supply voltage (V)	Output form	Pages for electrical spec.
TS5668N41 	ϕ 35	ϕ 6 (Blind hole type)	17 (Single turn)	DC+5	Line driver	7,8
TS5669N120 						
TS5667N120 						
TS5667N127 	ϕ 37.5	17/33 (1 turn/ 1 turn+ multi-turn)				
TS5667N420 	ϕ 46					
TS5667N320 	ϕ 48					
TS5667N253 	ϕ 100	ϕ 30 (Through type)				
TS5667N650 	ϕ 135	ϕ 65 (Through type)				

Specifications of Encoders

Specifications of incremental encoders

Model	Outer dia. mm	Inner dia. mm	Length mm	A.Bch Resolution C/T	Supply Voltage V	Output form	Consumption Current Max.	Output Phase		Response frequency KHz
TS5200N3□□ Series	φ 35	φ 6 (Blind hole type)	31.5	500, 1,000 1,024, 2,000	DC+5	Line driver ※1 ※2	200mA	A,B,Z,U,V,W U,V,W Correspond to 4.6.8 poles.	A,B,Z,U,V,W U,V,W Correspond to 4.6.8 poles.	200
TS5200N3□5 Series	φ 37.5 (With cover)		35	2,048, 2,500 3,000						
TS5200N5□□ Series	φ 48 (With cover)	φ 8 (Through type)	35	1,000, 1,024 2,000, 2,048 2,500, 3,000 5,000, 6,000						
TS5200N4□□ Series	φ 60 (With cover)	φ 10~ φ 20 (Through type)	42	1,000, 1,024 2,000, 2,500 5,000, 6,000 8,192						
TS5200N1□□ Series	φ 100 (With cover)	φ 30 (Through type)	51	8,192, 10,000						
			43	512, 1,024	DC+12~15	Complemental ※3	140mA	A,B,Z,U,V,W		100
							40mA	A,B		85

Examples of circuit at output stage

※1 Line driver (parallel type)

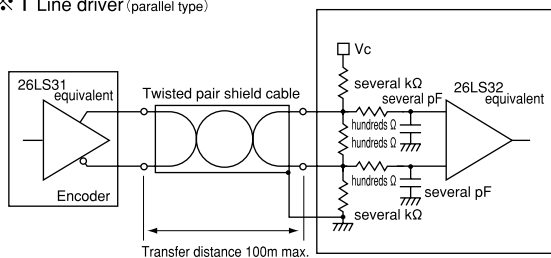

※2 Line driver (wire-saving type)

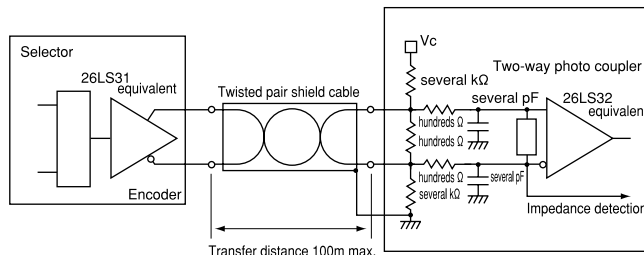

※3 Complemental

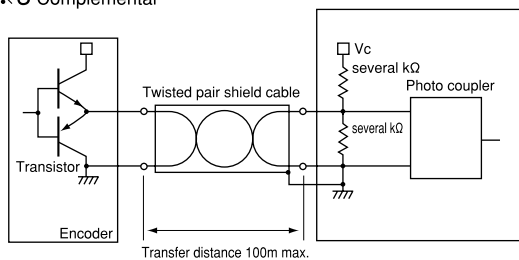

※4 Line driver (Two-way communication)

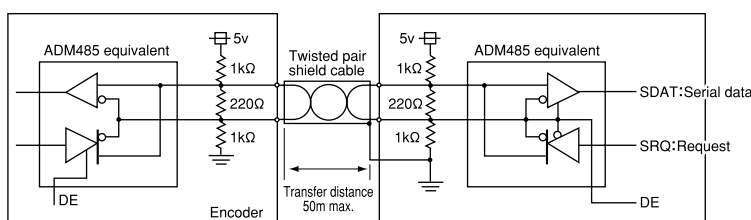

Specifications of absolute encoders

Model	Outer dia. mm	Inner dia. mm	Length mm	Resolution bit	Supply Voltage V	Output form	Consumption Current mA	Output method	Inner capacitor	Max Rotating speed min ⁻¹
TS5668N41	φ 35	φ 6 (Modular)	18	17 (Single turn)	DC+5	Line driver ※4	70mA TYP	Two-way serial output	Without	6,000
TS5669N120										
TS5667N120 ※5 (N127)	φ 35 (φ 37.5)	φ 6 (Blind hole type)	41 43	17/33bit (1turn/ 1turn+ multi turn)					With	
TS5667N420 ※5 (N320)	φ 46 (φ 48)	φ 8 (Blind hole type)	38 41.6							
TS5667N253	φ 100	φ 30 (Through)	51						3,000	
TS5667N650	φ 135	φ 65 (Through)	59						Without	1,500

※5 N127 and N320 are with cover.

Model	Mounting tolerances		Starting torque	Operating temp. °C	Protective construction	Vibration		Shock (3times for each axis)	Mass kg	Pages for outline	Page for instal.
	Radial	Axial				2h for each axis	Constantly				
TS5200N3□□ Series	±0.025 mm	±0.10 mm	5.9×10 ⁻³ N·m {60gf·cm}	-20~+85	Not enclosed	5~40Hz Full amplitude 1.5mm 49m/s ² {5G} 40~200Hz	9.8m/s ² {1G}	490m/s ² (11ms) {50G}	0.2 (0.25)	11	19
TS5200N3□5 Series			9.8×10 ⁻³ N·m {100gf·cm}		980m/s ² (11ms) {100G}						
TS5200N5□□ Series			6.0×10 ⁻² N·m {612gf·cm}		490m/s ² (13ms) {50G}						
TS5200N4□□ Series	±0.075 mm	±0.17 mm	6.0×10 ⁻² N·m {612gf·cm}	-10~+70	IP40	98m/s ² {10G}		490m/s ² (13ms) {50G}	0.8	13	

■ Output wave form (Incremental)

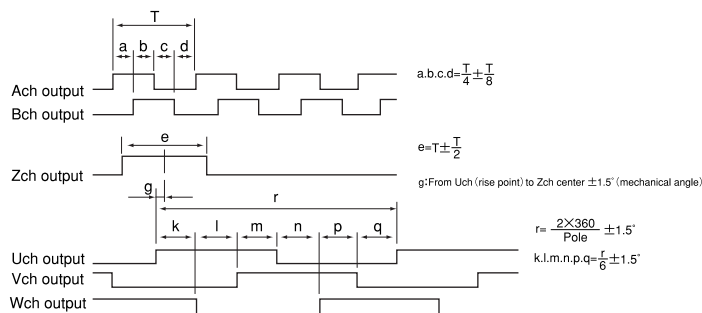

■ Timing chart for wire-saving type (Incremental)

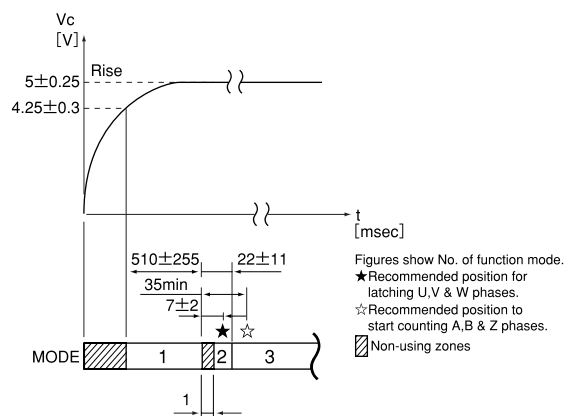

Output signal wire	MODE		
	1	2	3
Output wire 1	HZ	Uch	Ach
Output wire 2	HZ	Vch	Bch
Output wire 3	HZ	Wch	Zch

HZ : High impedance

Model	Mounting tolerances		Starting torque	Operating temp. °C	Protective construction	Vibration		Shock (3times for each axis)	Mass kg	Pages for outline	Page for instal.	Receiving ASIC model
	Radial	Axial				2h for each axis	Constantly					
TS5668N41	±0.005 mm	±0.1 mm	—	—	Not enclosed	5~58Hz Full amplitude 1.5mm	9.8m/s ² {1G}	1,960m/s ² (11ms) {200G}	0.03	14	19	AU5561N1
TS5669N120												
TS5667N120 (N127)	±0.025 mm	±0.05 mm	5.9×10 ⁻³ N·m {60gf·cm}	-10~+85	IP40	58~2,000Hz 98m/s ² {10G}	9.8m/s ² {1G}	1,960m/s ² (11ms) {200G}	0.06 (0.08)	15	19	AU5561N1
TS5667N420 (N320)			9.8×10 ⁻³ N·m {100gf·cm}						0.08 (0.10)			
TS5667N253			7.9×10 ⁻³ N·m {810gf·cm}						1.2			
TS5667N650									2.0	17		

Model Designation of Encoders

Incremental Encoders

Hollow Shaft Type

Function **OIH** -

Optical Incremental Hollow Shaft Encoder

Size ϕ	Resolution C/T	Model No.	N-number		
			4 poles	6 poles	8 poles
35 : ϕ 35mm ※1	500	TS5204	N300 (N305)	N310 (N315)	N330 (N335)
	1,000	TS5207			
	1,024	TS5208			
	2,000	TS5212			
	2,048	TS5213			
	2,500	TS5214			
	3,000	TS5231			
48 : ϕ 48mm	1,000	TS5207	N500	N510	N530
	1,024	TS5208			
	2,000	TS5212			
	2,048	TS5213			
	2,500	TS5214			
	3,000	TS5231			
	5,000	TS5217			
6,000	TS5233				
60 : ϕ 60mm	1,000	TS5207	N400	N410	N430
	1,024	TS5208			
	2,000	TS5212			
	2,500	TS5214			
	5,000	TS5217			
	6,000	TS5233			
	8,192	TS5246			
100 : ϕ 100mm	8,192	TS5246	N112	N113	N114
	10,000	TS5236			

P - **L** - **5V**

Voltage
5V

Output phase
3 : 6 phase wire-saving type
6 : 6 phase parallel type
(6 phase=A, B, Z, U, V, W)

Output form
L : Line driver

U, V, W poles
4 : 4 poles
6 : 6 poles
8 : 8 poles

Model No. : TS52N

Function **OIH** -

Optical Incremental Hollow Shaft Encoder

Size ϕ	Resolution C/T	Model No.	N-number
100 : ϕ 100mm	512 ※2	TS5226	N120
	1,024 ※2	TS5208	

C/T - **P2** - **15V**

Voltage
15V

Output phase
2 : A, B phase only

Output form
P : Complemental

※ 1 Covered type is also 35. (Size: ϕ 37.5mm)
 ※ 2 Complemental is applicable only to OIH 100-512,1024 C/T.

Model Designation of Encoders

Absolute Encoders

Single-turn Absolute

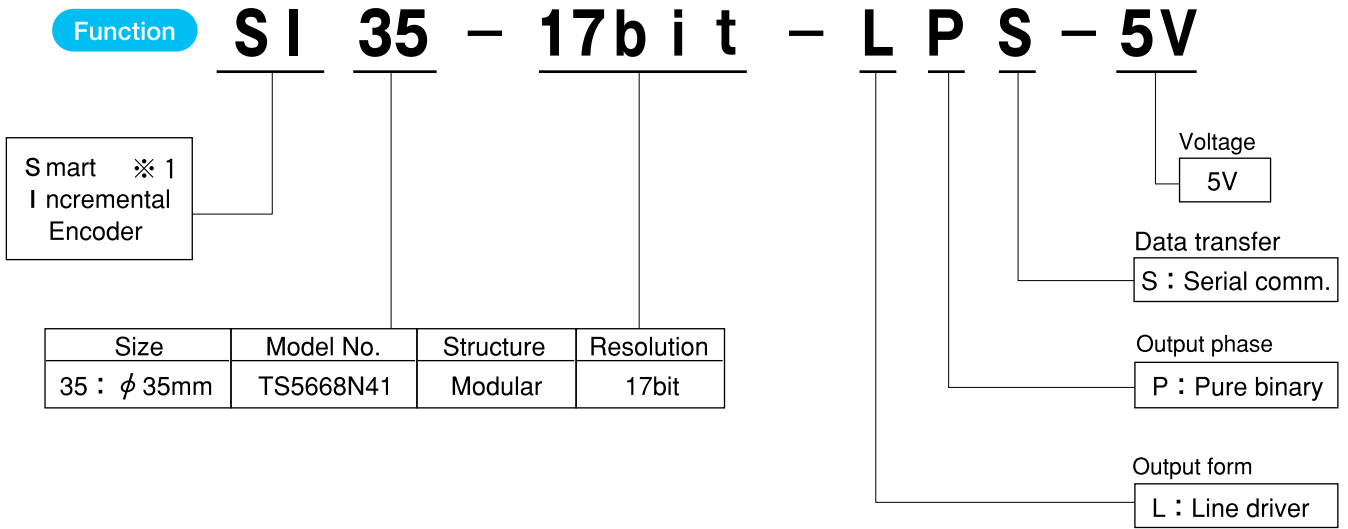

Multi-turn Absolute

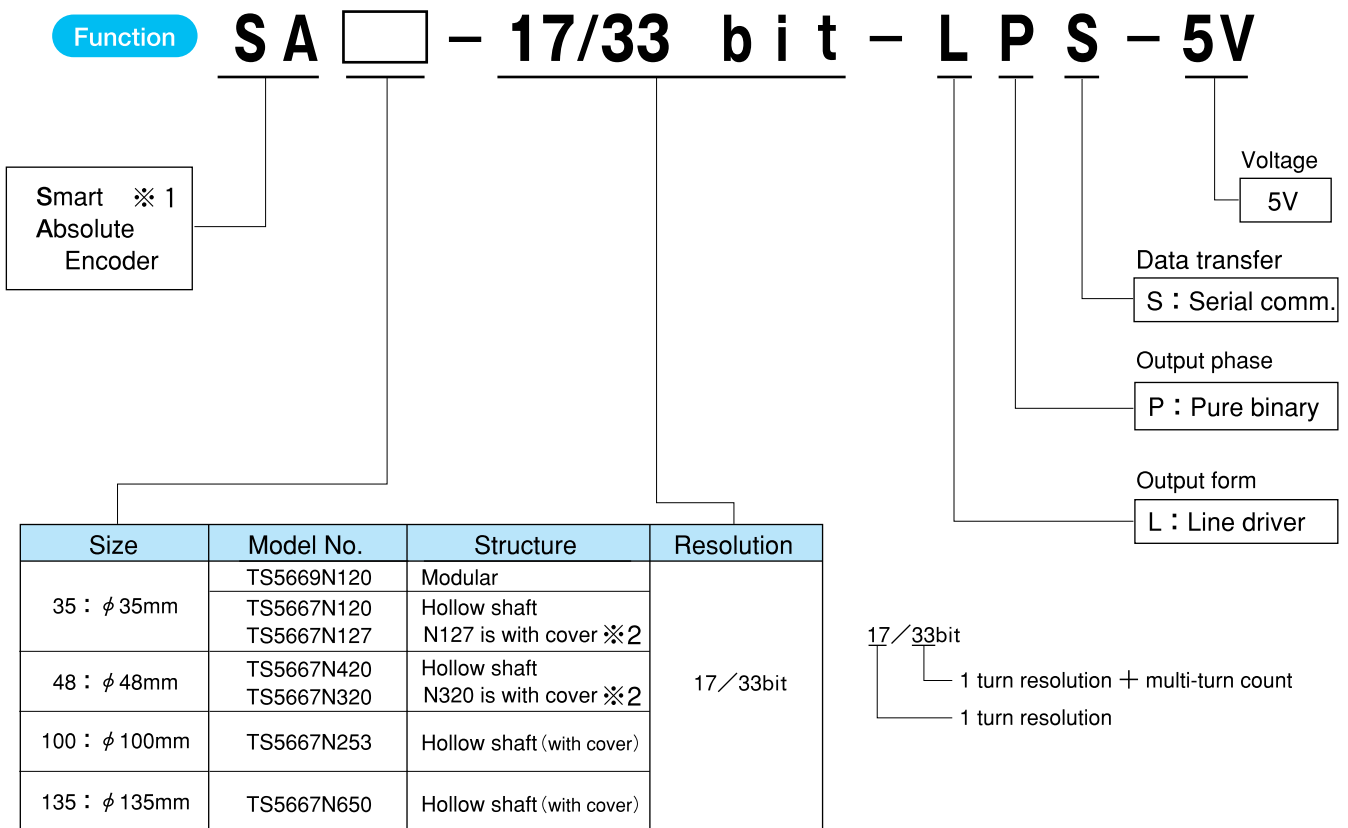

Model No. : TS566□N□□□

※1 : Smart means function of our absolute encoder, Smart Abs®.
 ※2 : Covered type is also 35 or 48.

Model Designation of Encoders

Dimensions of Encoders

Incremental Encoders

Outline (mm)

TS5200N3 Series (φ35)

(Without cover)

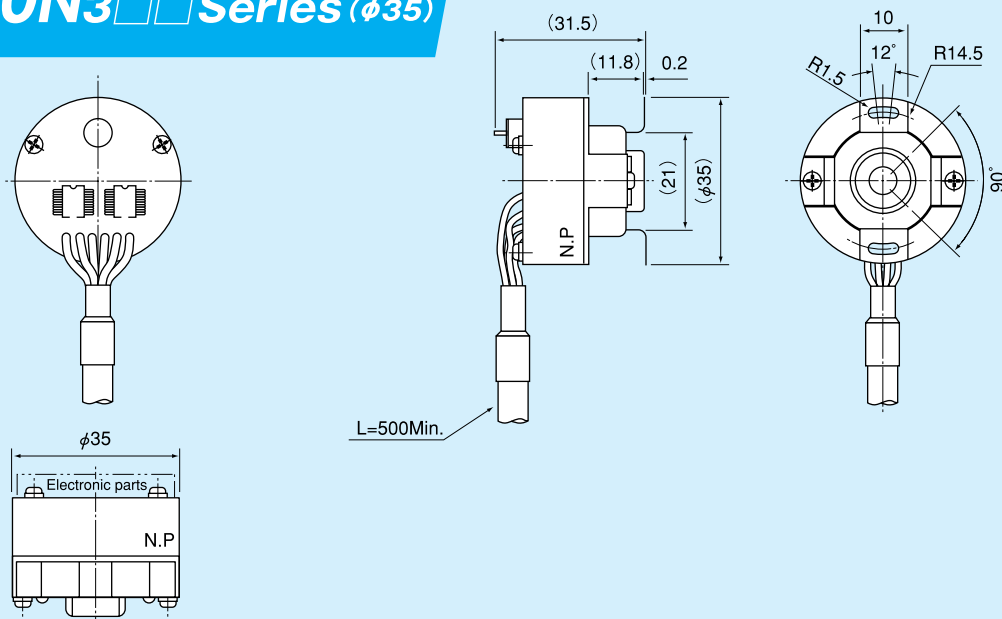

TS5200N35 Series (φ38)

(With cover)

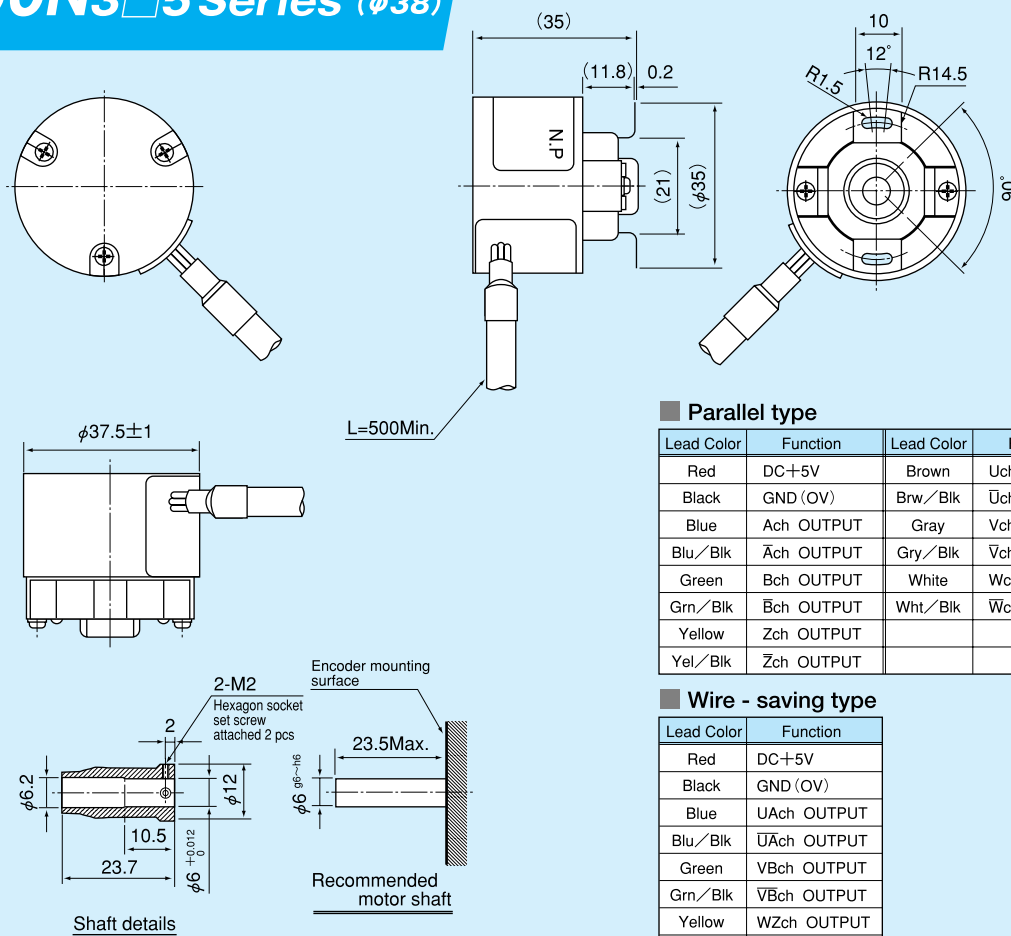

Parallel type

Lead Color	Function	Lead Color	Function
Red	DC+5V	Brown	Uch OUTPUT
Black	GND (OV)	Brw/Blk	Ūch OUTPUT
Blue	Ach OUTPUT	Gray	Vch OUTPUT
Blu/Blk	Āch OUTPUT	Gry/Blk	Ṽch OUTPUT
Green	Bch OUTPUT	White	Wch OUTPUT
Grn/Blk	B̄ch OUTPUT	Wht/Blk	W̄ch OUTPUT
Yellow	Zch OUTPUT		
Yel/Blk	Z̄ch OUTPUT		

Wire - saving type

Lead Color	Function
Red	DC+5V
Black	GND (OV)
Blue	UAch OUTPUT
Blu/Blk	ŪAch OUTPUT
Green	VBch OUTPUT
Grn/Blk	ṼBch OUTPUT
Yellow	WZch OUTPUT
Yel/Blk	W̄Zch OUTPUT

● Please refer to page 7~8 for electric specifications, and page 19~20 for installation.

TS5200N5 Series (φ48)

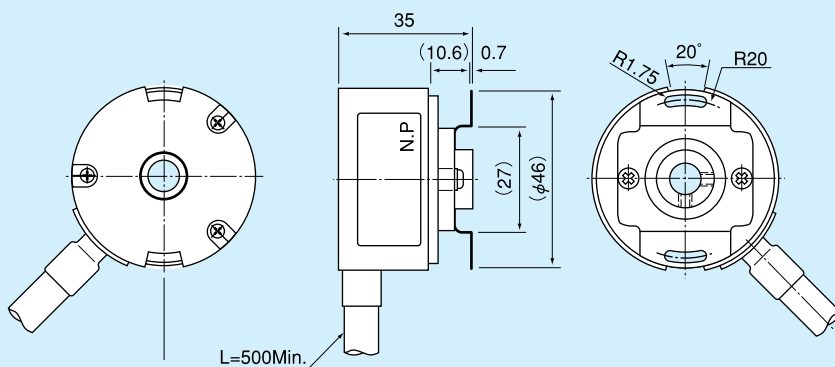

Wire - saving type

Lead Color	Function
Red	DC+5V
Black	GND (OV)
Blue	UAch OUTPUT
Blu/Blk	U \bar{A} ch OUTPUT
Green	VBch OUTPUT
Grn/Blk	V \bar{B} ch OUTPUT
Yellow	WZch OUTPUT
Yel/Blk	W \bar{Z} ch OUTPUT

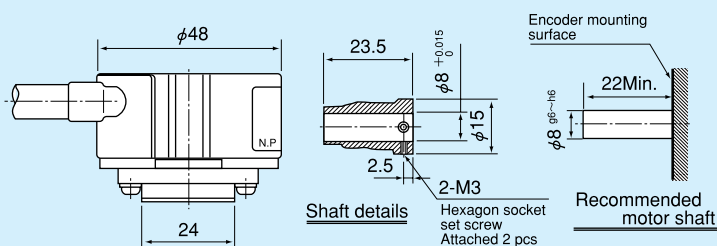

Parallel type

Lead Color	Function	Lead Color	Function
Red	DC+5V	Brown	Uch OUTPUT
Black	GND (OV)	Brw/Blk	U \bar{c} h OUTPUT
Blue	Ach OUTPUT	Gray	Vch OUTPUT
Blu/Blk	A \bar{c} h OUTPUT	Gry/Blk	V \bar{c} h OUTPUT
Green	Bch OUTPUT	White	Wch OUTPUT
Grn/Blk	B \bar{c} h OUTPUT	Wht/Blk	W \bar{c} h OUTPUT
Yellow	Zch OUTPUT		
Yel/Blk	Z \bar{c} h OUTPUT		

TS5200N4 Series (φ60)

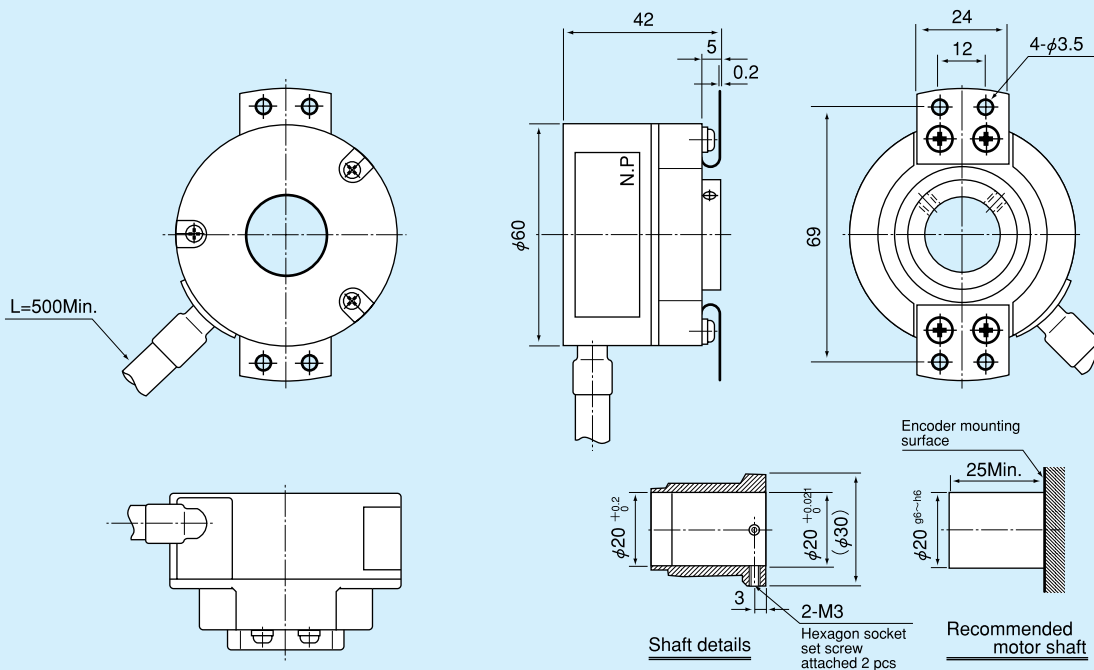

Parallel type

Lead Color	Function	Lead Color	Function
Red	DC+5V	Brown	Uch OUTPUT
Black	GND (OV)	Brw/Blk	U \bar{c} h OUTPUT
Blue	Ach OUTPUT	Gray	Vch OUTPUT
Blu/Blk	A \bar{c} h OUTPUT	Gry/Blk	V \bar{c} h OUTPUT
Green	Bch OUTPUT	White	Wch OUTPUT
Grn/Blk	B \bar{c} h OUTPUT	Wht/Blk	W \bar{c} h OUTPUT
Yellow	Zch OUTPUT		
Yel/Blk	Z \bar{c} h OUTPUT		

Wire - saving type

Lead Color	Function
Red	DC+5V
Black	GND (OV)
Blue	UAch OUTPUT
Blu/Blk	U \bar{A} ch OUTPUT
Green	VBch OUTPUT
Grn/Blk	V \bar{B} ch OUTPUT
Yellow	WZch OUTPUT
Yel/Blk	W \bar{Z} ch OUTPUT

● Please refer to page 7~8 for electric specifications, and page 19~20 for installation.

Dimensions of Encoders

TS5236N1 12.1 13.1 14

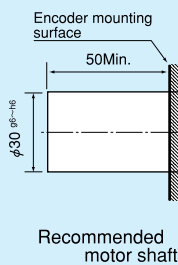
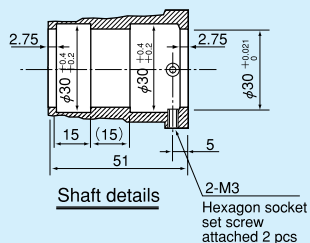
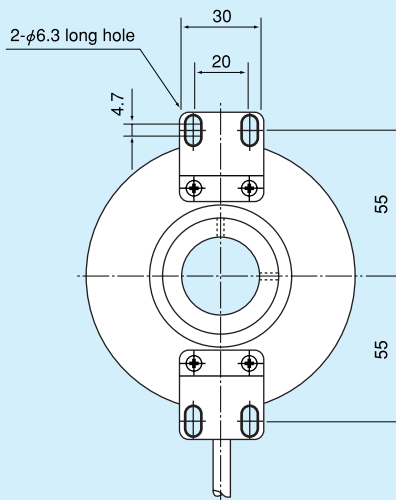
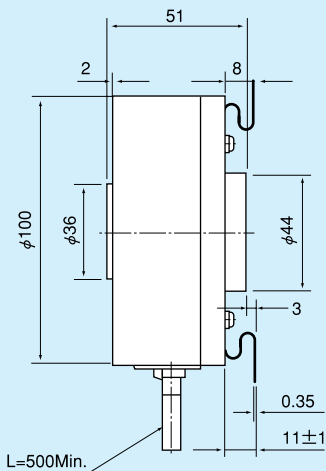
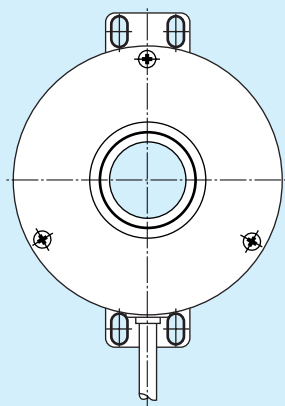

Parallel type

Lead Color	Function	Lead Color	Function
Red	DC+5V	Brown	Uch OUTPUT
Black	GND (0V)	Brw/Blk	Ūch OUTPUT
Blue	Ach OUTPUT	Gray	Vch OUTPUT
Blu/Blk	Āch OUTPUT	Gry/Blk	V̄ch OUTPUT
Green	Bch OUTPUT	White	Wch OUTPUT
Grn/Blk	B̄ch OUTPUT	Wht/Blk	W̄ch OUTPUT
Yellow	Zch OUTPUT		
Yel/Blk	Z̄ch OUTPUT		

TS5200N120 Series

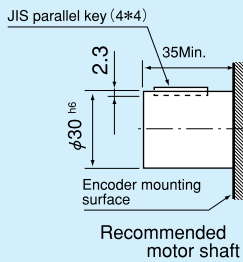
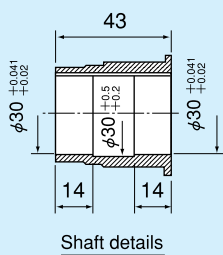
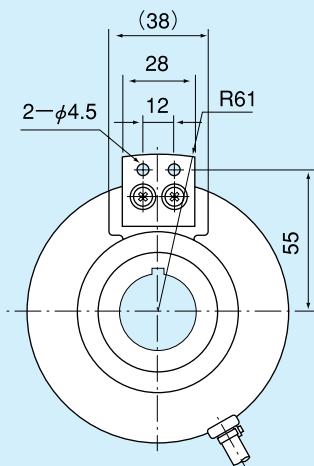
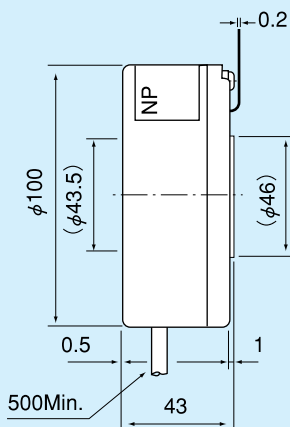
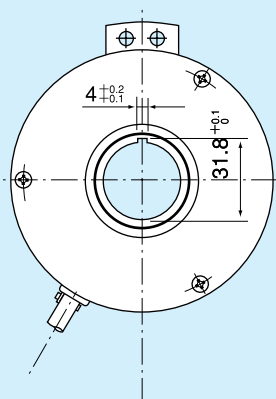

Lead Color	Function
Red	DC+12~15V
Black	GND (0V)
Green	Ach OUTPUT
Blue	Bch OUTPUT
Shield	CASE GND

● Please refer to page 7~8 for electric specifications, and page 19~20 for installation.

Absolute Encoders

Outline (mm)

TS5668N41 (Single-turn)

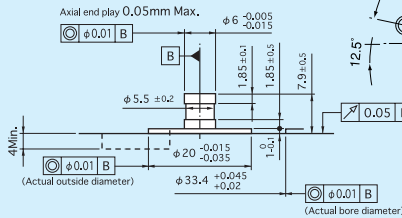
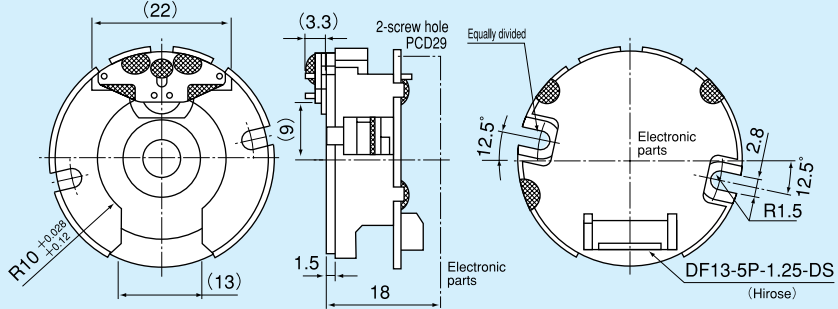
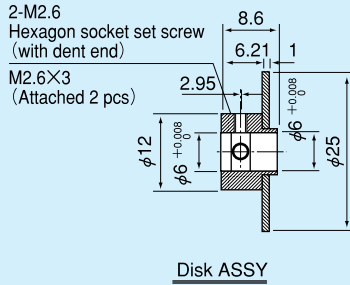

Recommended motor shaft and dimensions on mounting place.

Pin	Function	
1	—	—
2	GND	—
3	SD	Serial data
4	SD	Serial data
5	Vcc	Power DC+5V±5%

Connector : Hirose DF13-5P-1.25DS (20)

TS5669N120 (Multi-turn)

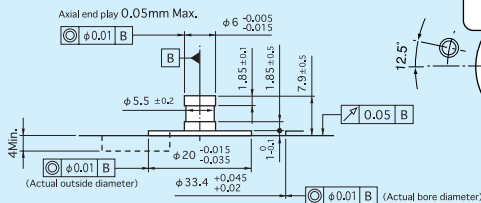
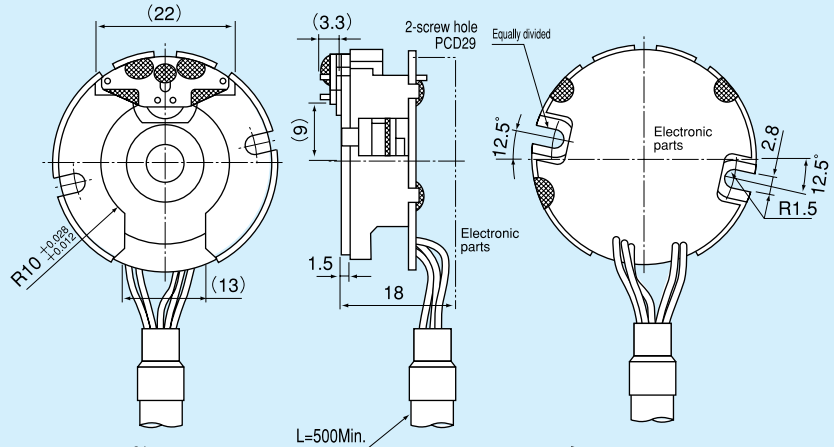
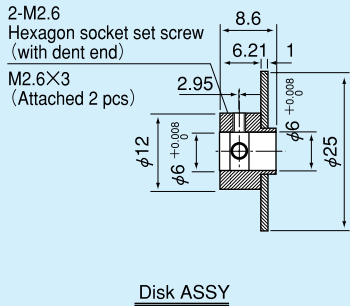

Recommended motor shaft and dimensions on mounting place

Lead color	Function	
Red	Vcc	Power DC+5V±5%
Black	GND	—
Brown	VB	External battery
Brn/Blk	GND	—
Blue	SD	Serial data
Blu/Blk	SD	Serial data

Please refer to page 7~8 for electric specifications, and page 19~20 for installation.

Dimensions of Encoders

Outline (mm)

TS5667N120

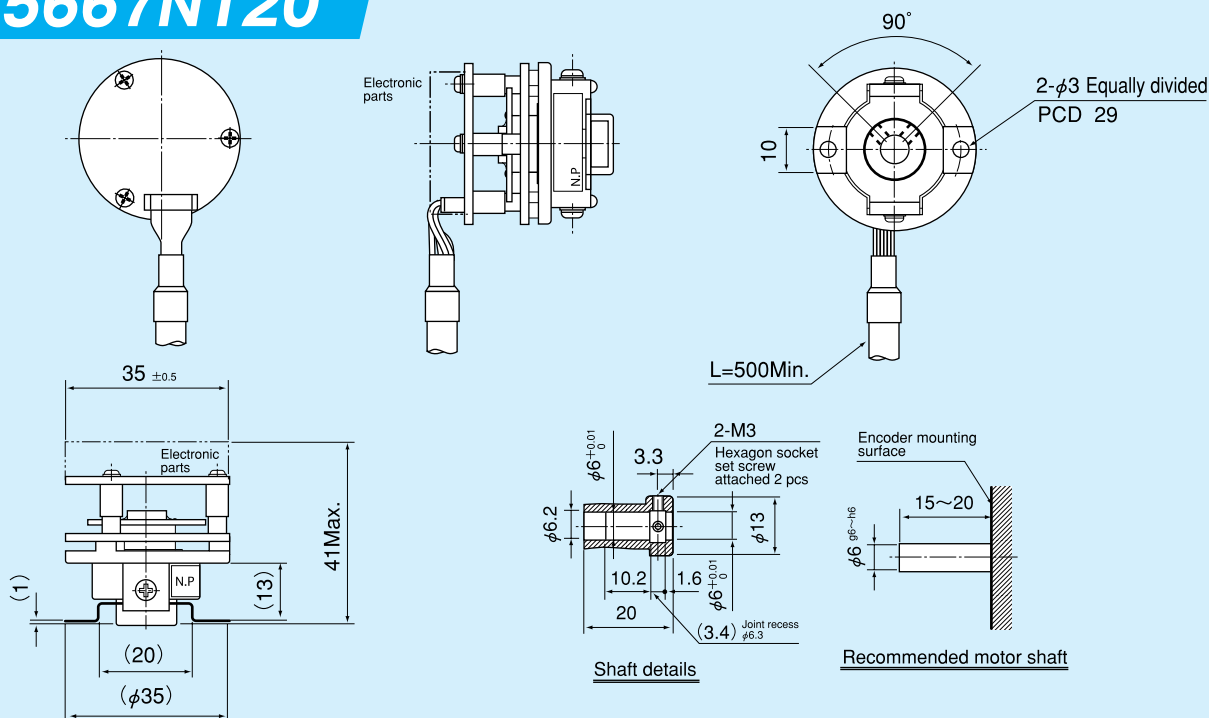

TS5667N127 (With cover)

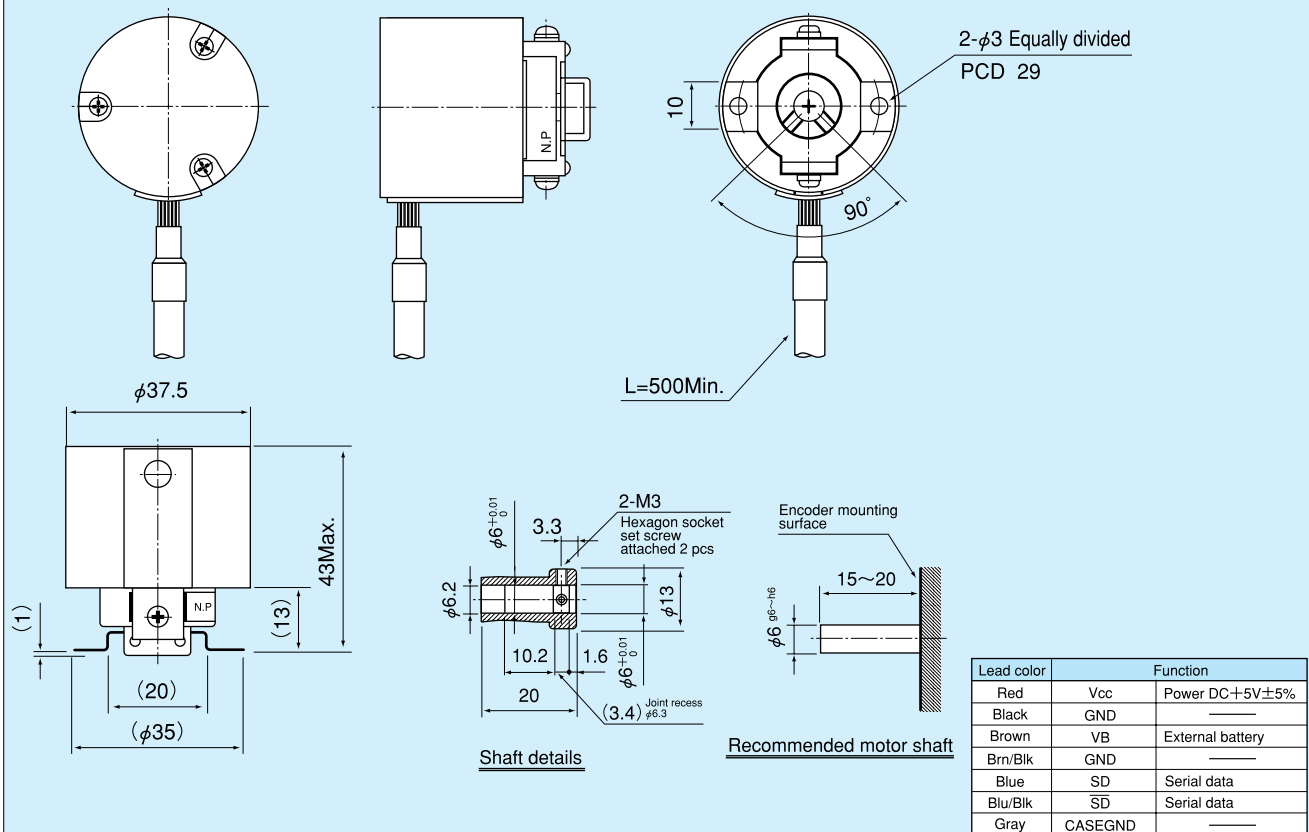

Lead color	Function	
Red	Vcc	Power DC+5V±5%
Black	GND	—
Brown	VB	External battery
Brn/Blk	GND	—
Blue	SD	Serial data
Blu/Blk	SD	Serial data
Gray	CASEGND	—

● Please refer to page 7~8 for electric specifications, and page 19~20 for installation.

Outline (mm)

TS5667N420

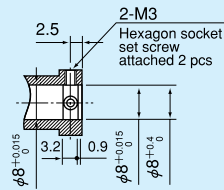
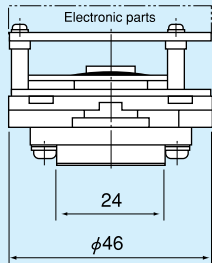
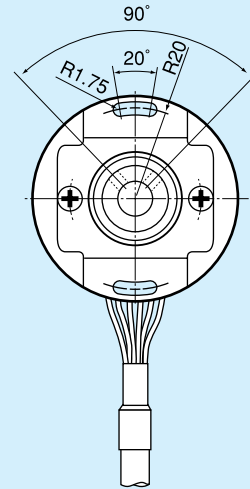
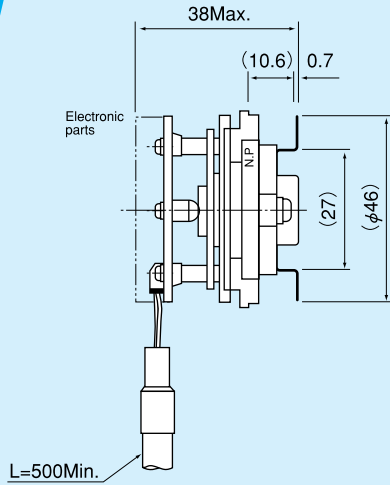
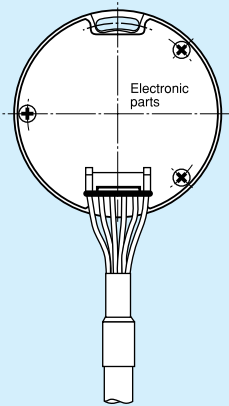

Shaft details

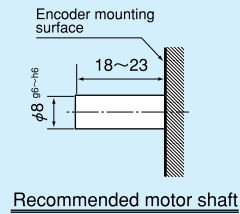

Recommended motor shaft

TS5667N320 (With cover)

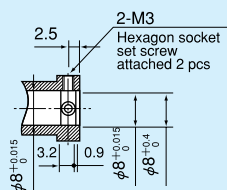
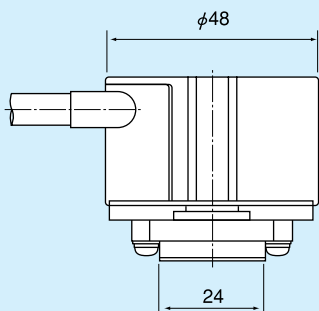
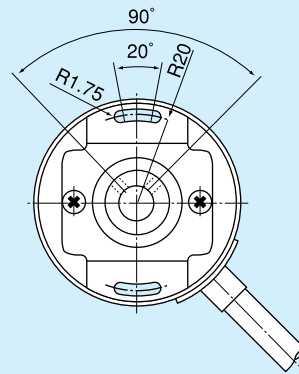
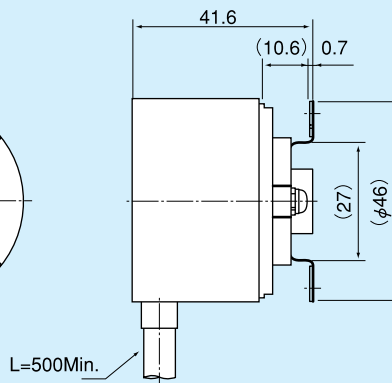
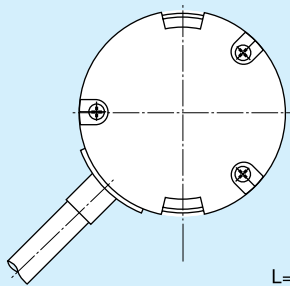

Shaft details

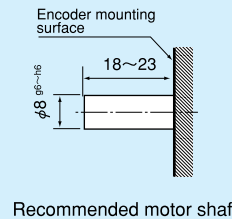

Recommended motor shaft

Lead color	Function	
Red	Vcc	Power DC+5V±5%
Black	GND	—
Brown	VB	External battery
Brn/Blk	GND	—
Blue	SD	Serial data
Blu/Blk	SD	Serial data
Gray	CASE GND	—

● Please refer to page 7~8 for electric specifications, and page 19~20 for installation.

Dimensions of Encoders

Outline (mm)

TS5667N253

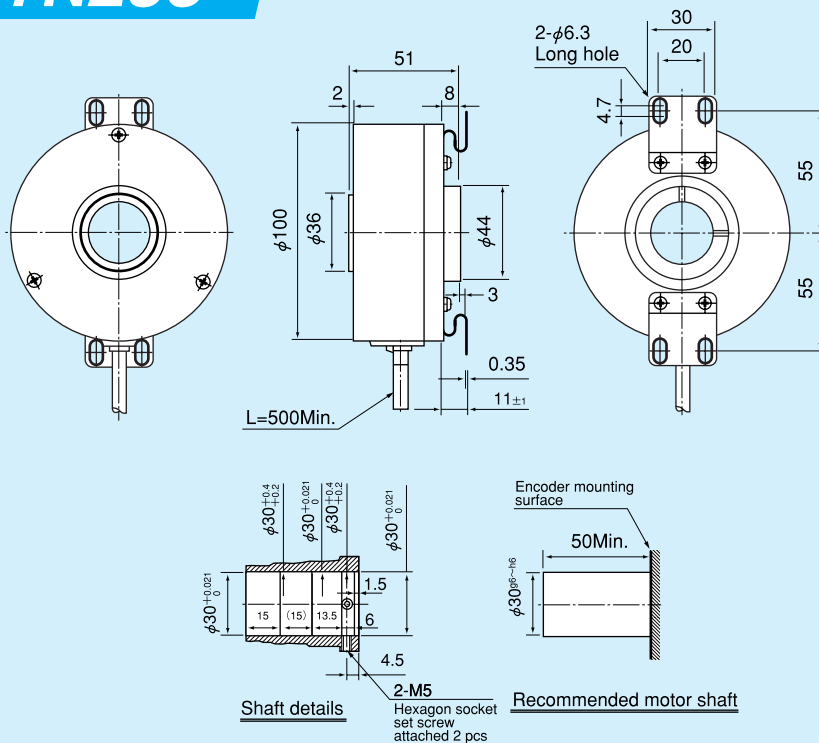

TS5667N650

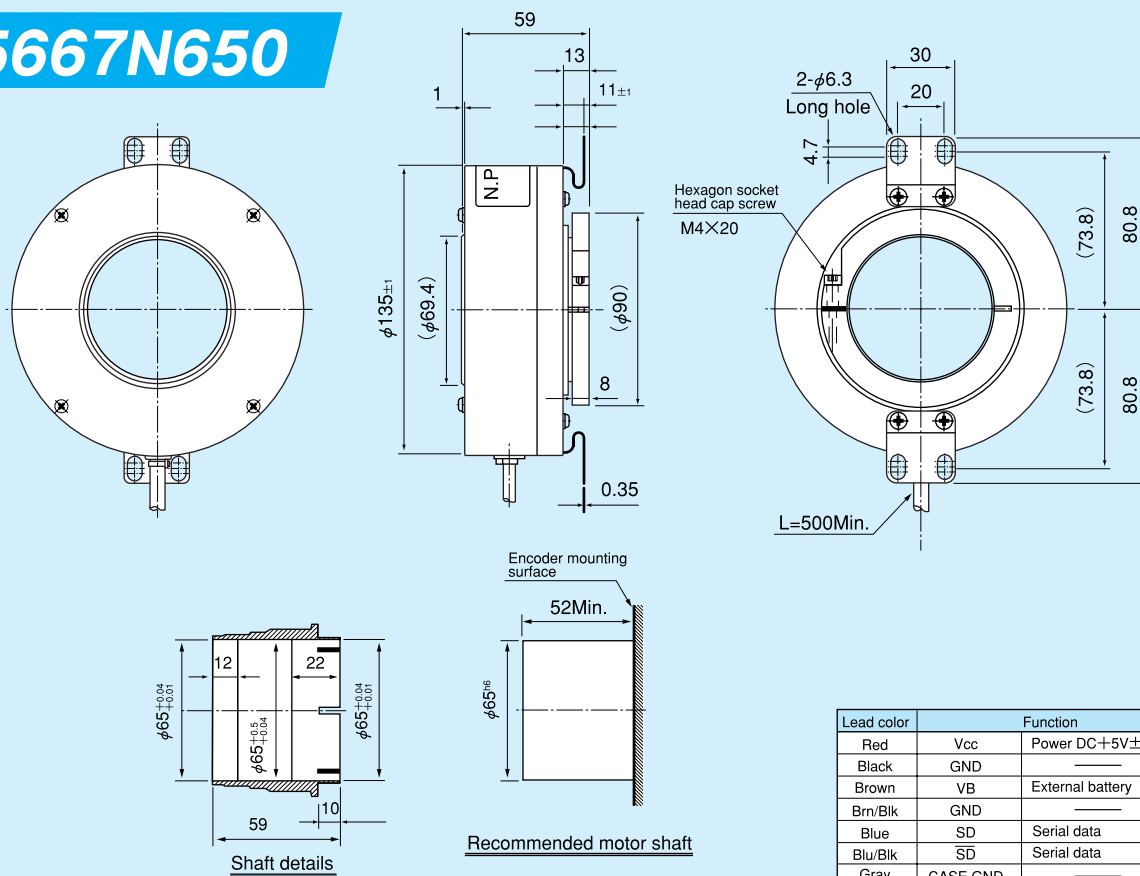

Lead color	Function	
Red	Vcc	Power DC +5V ±5%
Black	GND	—
Brown	VB	External battery
Brrn/Blk	GND	—
Blue	SD	Serial data
Blu/Blk	SD	Serial data
Gray	CASE GND	—

● Please refer to page 7~8 for electric specifications, and page 19~20 for installation.

Serial Signal Receiver IC



AU5561N1

Features

- (1) A serial signal receiver IC which provides serial-to-parallel conversion and interfaces with a 16/32 bit CPU or DSP bus.
Dedicated to TS5667, TS5668 and TS5669.
- (2) Provides interrupt signals to synchronize with a CPU.
- (3) Capable of reading encoder data without a CPU in two ways (Manual Mode) : ID3 (Single-turn data, Multi-turn data, and Alarm) .

Specifications

※For details, please refer to spec. of AU5561N1 (Drawing No.801100401E50)

Supply voltage	5.0V±10%
Source current	40mA Max
Permissible voltage	Max : V _{DD} Min : V _{SS}
Output current / Terminal	±24mA Max
Permissible Dissipation	±200mW Max
Operating temperature	-20~+85°C
Storage temperature	-65~+150°C

System Connection

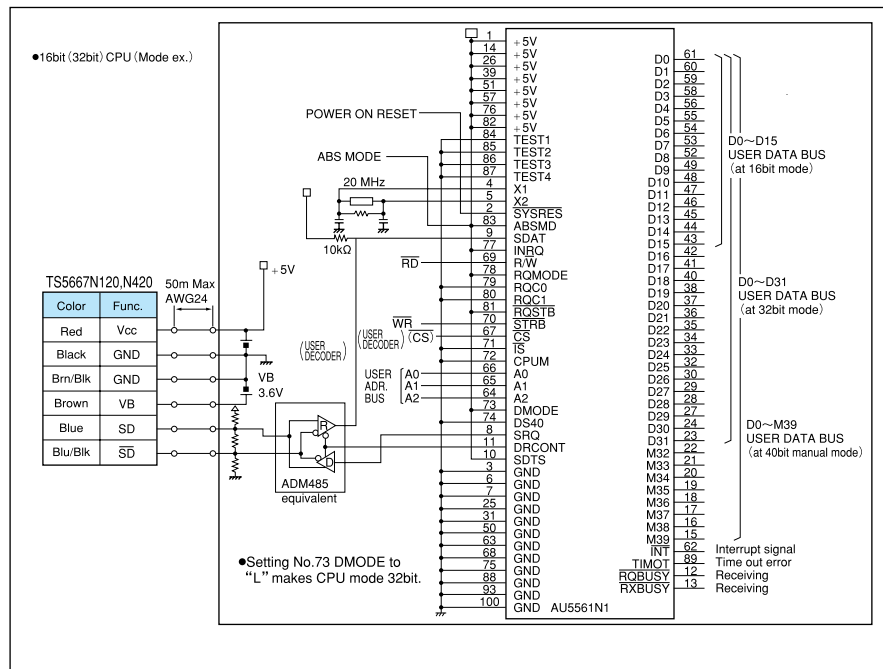

Outline

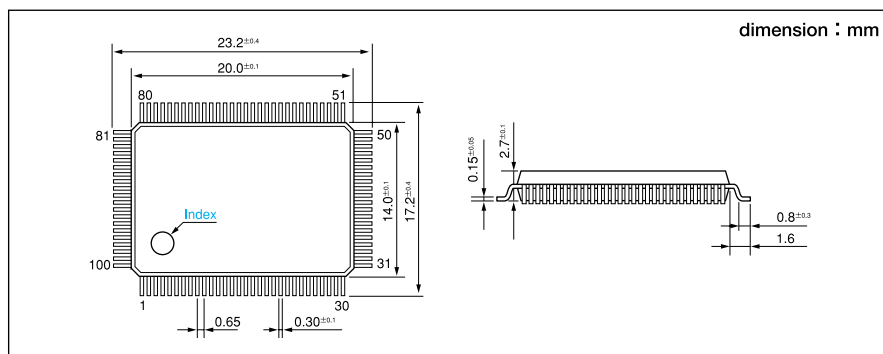

Installation of Encoders

- ① For dimensions of attaching sections, please refer to respective outlines.
 ② Regarding the installation for modular type encoders (Absolute encoders), please refer to the following manual.

TS5 6 6 8 : 8 0 1 3 0 0 1 1 3 E 5 0

TS5 6 6 9 : 8 0 1 3 0 0 1 1 6 E 5 0

- ③ In case of a hollow shaft encoder (Blind hole type and Through type)
 After coupling the hollow shaft of the encoder with the drive shaft with screws in a position where encoder flanges are easily fixed, fix the flanges.
 If the flanges are fixed in a warped state, they will wear on the ball bearing and may cause damage to the mounting plate. Please apply "screw lock" to each screw.

- ④ Mounting tolerances
 Radial 0.05mm TIR Max.
 Axial ± 0.1 mm Max.
 Shaft runout 0.1° Max.

Adding undercut at a clamping section of the shaft set screw may cause shaft runout.

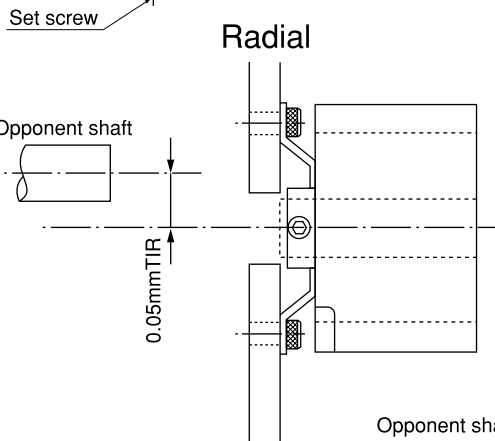
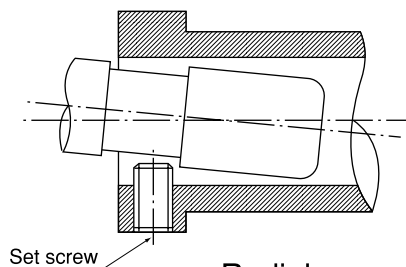

Radial

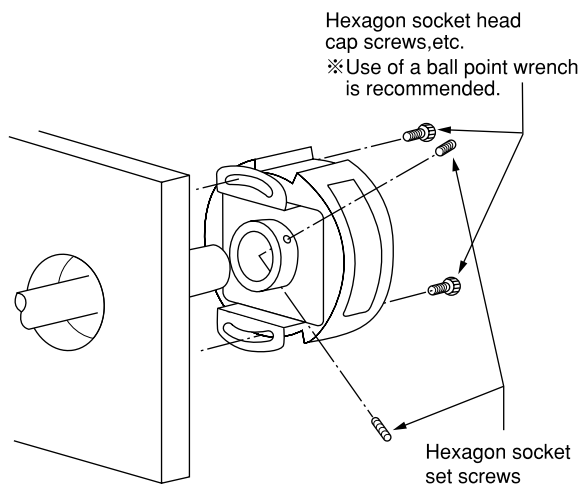

Axial

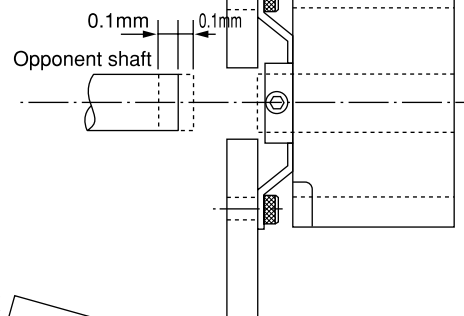

Shaft runout

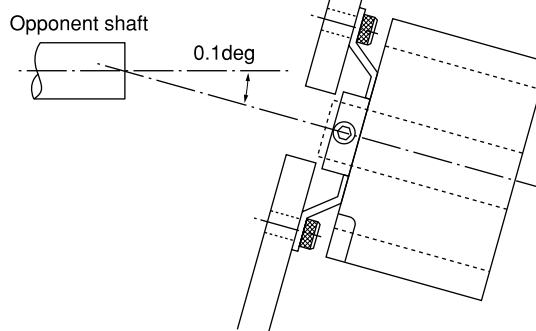

Notice in Handling Encoders

An encoder is a precise instrument and it must be used with full understanding of the safety notes to maximize its performance.

The following is the gist of safety precautions :

(1) Safety notes on unpacking

- ① After opening the package, check the appearance of the encoder for any abnormality.
- ② In opening the package of encoders which are provided with flanges, do not give excessive force on the flanges.
- ③ Do not carry or shake the encoder by the leads.
- ④ In carrying the encoder, be careful not to jar it because such a shock can damage the quality of the encoder.

(2) Safety notes on installation

- ① Attach the encoder according to the handling manual. Take ample precaution against vibration, noise, attaching direction, ambience (temperature, humidity, dust) , etc.
- ② Never use the encoder in the presence of corrosive gas or liquid.
- ③ Never use the encoder in the presence of radiation.
- ④ In installing the encoder, do not give forcible impact to it.

(3) Safety notes on wiring

- ① Check the power supply and signal wires of the encoder.
- ② When miss-wiring or mis-operation of the encoder is made, replace the encoder with a new one because damage may remain in the old encoder.
- ③ Wire the power line of the motor and the power/signal wires of the encoder as far away from each other as possible in order to avoid noise mixing in.
(Do not wire them in the same duct.)

(4) Safety notes on pre-operation

- ① The earthing for a motor or an instrument which the encoder is attached to should be 100Ω or less.
- ② Never subject the encoder terminal to withstand a voltage test or a megger test.

(5) Safety notes on operation

- ① Be sure to use the encoder under the specified ambient temperature and relative humidity. (When the encoder is attached to a motor, the ambient temperature is the surface temperature of the motor frame and shaft.)
- ② Do not drop or splash any water or oil onto the products.
- ③ Consult us about the use of the encoder in a place with much vibration and shock.

Digest of Resolvers

Resolvers (Singlsyn®)

Size	Max.Outer Dia. (mm)	Inner.Dia. (mm)	Number of multiple	Combination with Smartcoder		Pages for electric spec.
				Resolution (12bit)	Supply volt. (from AU6802)	
S-10 TS2223N12E102 (2×) TS2223N13E102 (3×) TS2223N14E102 (4×) 	φ 25.00	φ 6.00	2×	8,192		
			3×	12,288		
			4×	16,384		
S-15 TS2224N12E102 (2×) TS2224N13E102 (3×) TS2224N14E102 (4×) 	φ 37.00	φ 9.52	2×	8,192	DC+5V	23,24
			3×	12,288		
			4×	16,384		
S-21 TS2225N12E102 (2×) TS2225N13E102 (3×) TS2225N14E102 (4×) 	φ 52.00	φ 12.70	2×	8,192		
			3×	12,288		
			4×	16,384		

Resolver (Smartsyn®)

Size	Max.Outer Dia. (mm)	Inner.Dia. (mm)	Number of multiple	Combination with Smartcoder		Pages for electric spec.
				Resolution	Supply volt. (from AU6802)	
S-08 TS2605N1E64 	φ 20.32	φ 4.00	1×	4,096 (=2 ¹²) or 1,024 (=2 ¹⁰)	DC+5V	23,24
S-10 TS2610N171E64 	φ 30.00	φ 6.00	1×			
S-15 TS2620N21E11 	φ 37.50	φ 9.52	1×			
S-21 TS2640N321E64 	φ 52.40	φ 12.70	1×			

Specifications of Resolvers

Specifications of Resolvers (Singsyn®)

Size	Model	Outer Dia. mm	Inner Dia. mm	Length (Thickness) mm	Number of Multiple ※1	Electrical Error	Max. Rotating Speed min ⁻¹	Mounting Tolerances	
								Radial	Axial
S-10	TS2223N12E102	φ 25.00	φ 6.00	16	2×	±60' Max	30,000以上	±0.05mm	±0.25mm
	TS2223N13E102				3×	±45' Max			
	TS2223N14E102				4×	±30' Max			
S-15	TS2224N12E102	φ 37.00	φ 9.52		2×	±60' Max			
	TS2224N13E102				3×	±45' Max			
	TS2224N14E102				4×	±30' Max			
S-21	TS2225N12E102	φ 52.00	φ 12.70	2×	±60' Max				
	TS2225N13E102			3×	±45' Max				
	TS2225N14E102			4×	±30' Max				

※1× is not available.

■ An electrical error caused by a stator eccentricity error of 0.05mm (Reference)

Function	2×	3×	4×
S-10	45'	10'	5'
S-15	35'	3'	2'
S-21	10'	2'	1'

Specifications of Resolvers (Smartsyn®)

Size	Model	Outer Dia. mm	Inner Dia. mm	Length (Thickness) mm	Number of Multiple	Electrical Error	Max. Rotating Speed min ⁻¹	Mounting Tolerances	
								Radial	Axial
S-08	TS2605N1E64	φ 20.32	φ 4.00	18	1×	±10' Max	30,000	TIR0.05mm	±0.25mm
S-10	TS2610N171E64	φ 30.00	φ 6.00	22					
S-15	TS2620N21E11	φ 37.50	φ 9.52	16			20,000		
S-21	TS2640N321E64	φ 52.40	φ 12.70	27.1					

■ An electrical error caused by a core eccentricity error of 0.05mm (Reference)

	TS2605N1E64	TS2610N171E64	TS2620N21E11	TS2640N321E64
Stator Core shift	8'	6'	4'	3'
Rotor Core shift	8'	6'	4'	3'

Size	Model	Operating temp.	Vibration	Shock	Humidity	Mass kg	Page for outline	Page for installation	Accuracy: Combination with Smartcoder (ex.)			
									Resolution	Electrical Error	Max Tracking Rate	
S-10	TS2223N12E102	-55~ +155°C	196m/s ² {20G} 10~500Hz 2 hours for each of 3 axes	980m/s ² {100G} 6ms 3 times for each of 6 axes 18 times in total	+60°C 90%Rh	0.023		25	29	4,096X2	±71'	30,000min ⁻¹
	4,096X3									±52'	20,000	
	4,096X4									±35'	15,000	
S-15	TS2224N12E102									4,096X2	±71'	30,000min ⁻¹
	TS2224N13E102									4,096X3	±52'	20,000
	TS2224N14E102									4,096X4	±35'	15,000
S-21	TS2225N12E102									4,096X2	±71'	30,000min ⁻¹
	TS2225N13E102									4,096X3	±52'	20,000
	TS2225N14E102									4,096X4	±35'	15,000

■ An electrical error caused by a rotor eccentricity error of 0.05mm (Reference)

Function	2×	3×	4×
S-10	30'	3'	3'
S-15	10'	2'	1'
S-21	3'	1'	1'

Size	Model	Operating temp.	Vibration	Shock	Humidity	Mass kg	Page for outline	Page for installation	Accuracy: Combination with Smartcoder (ex.)		
									Resolution	Electrical Error	Max Tracking Rate
S-08	TS2605N1E64	-55~ +155°C	196m/s ² {20G} 10~500Hz 2 hours for each of 3 axes	980m/s ² {100G} 6ms 3 times for each of 6 axes 18 times in total	+60°C 90%Rh Min.	0.030	26	30	4,096 (=2 ¹²) or 1,024 (=2 ¹⁰)	±31' or ±52'	30,000min ⁻¹
S-10	TS2610N171E64					0.040					20,000min ⁻¹
S-15	TS2620N21E11					0.065					
S-21	TS2640N321E64					0.280					

Dimensions of Resolvers

Resolvers (Singlsyn®)

Outline (mm)

Size **S-10** Model: TS2223 Series

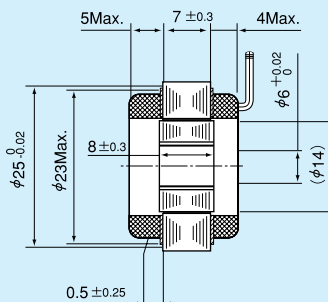
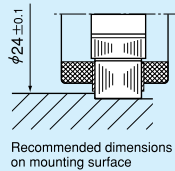

Mounting method of a stator and a rotor in the axial direction

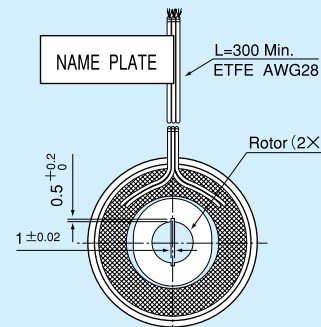

Size **S-15** Model: TS2224 Series

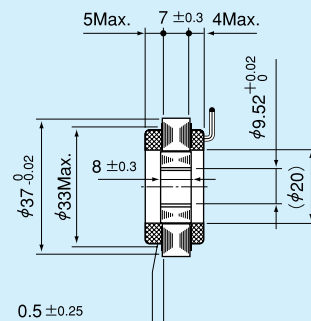

Mounting method of a stator and a rotor in the axial direction

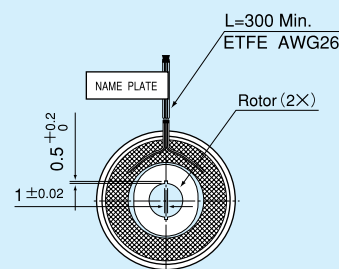

Size **S-21** Model: TS2225 Series

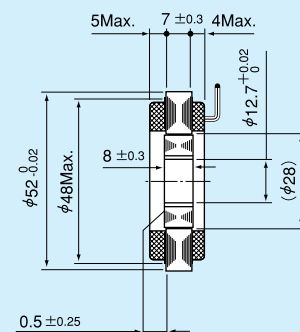

Mounting method of a stator and a rotor in the axial direction

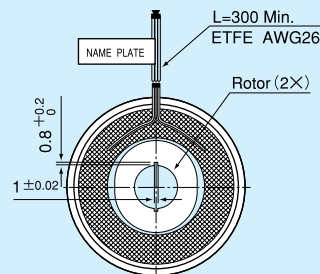

Number of multiple and shapes of rotors

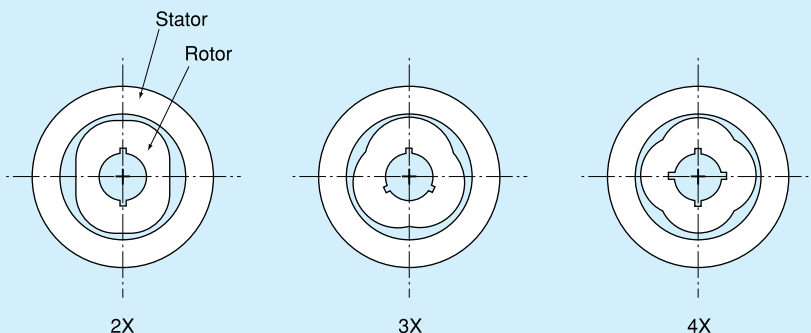

Wiring Diagram (Common to all models)

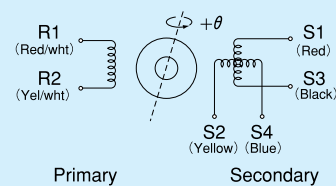

● Please refer to page 23~24 for electric specifications, and page 29 for installation.

Resolvers (Smartsyn®)

Outline (mm)

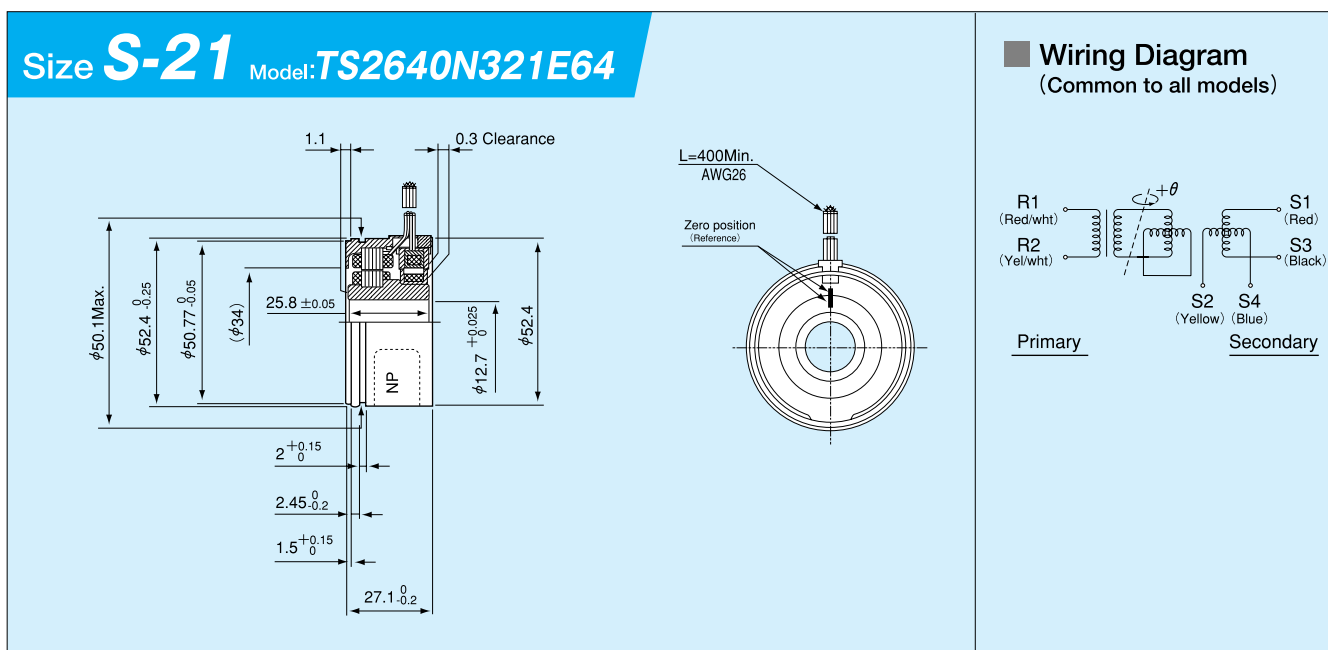
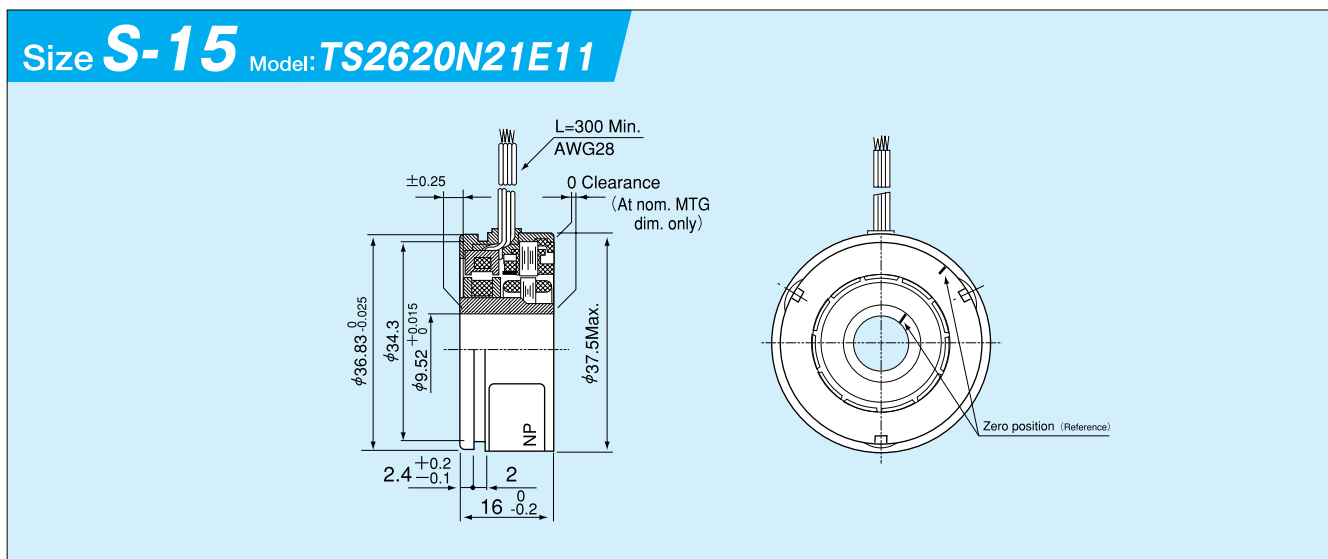
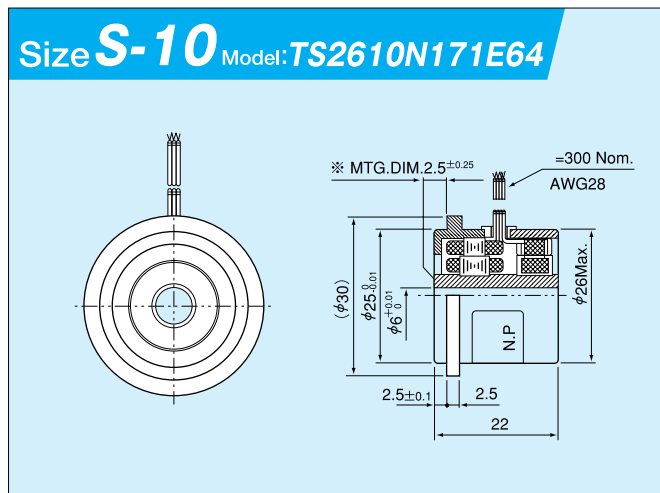
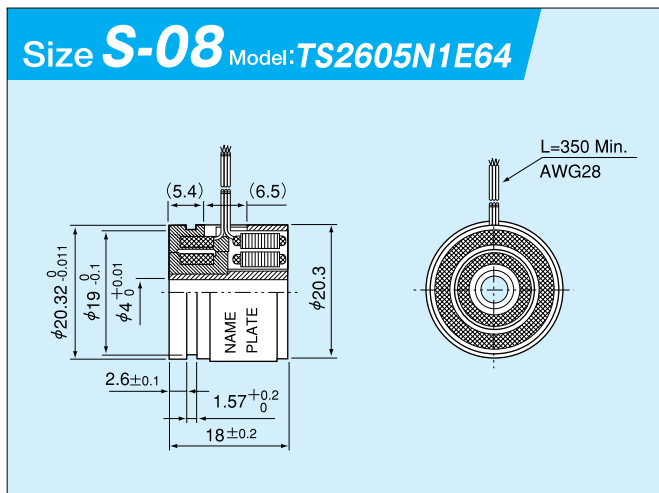

● Please refer to page 23~24 for electric specifications, and page 30 for installation.

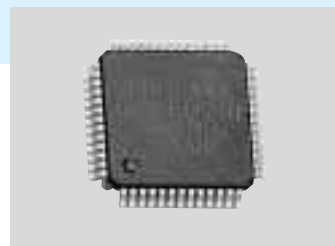

Model : AU6802N1

Features

- (1) Applicable to all of our resolvers. (1 phase excitation 2 phase output)
- (2) Vehicle-mount quality
 - Quality level : Transportation equipment involved in safety
 - Operating temperature range : -40~+125°C
- (3) High accuracy
- (4) Simple to use
 - Real time output (High tracking rate : 240,000min⁻¹/10bit resolution)
 - Single power supply of DC5V (Integrated oscillator for exciting resolver : 10/20KHz)
 - Small size and light weight (10×10mm, pin interval : 0.65mm, 52pin TQFP, Mass 0.3g)
 - Built-in test (Internal error detection) function
 - Pulse / Parallel / Bus + Serial output (Selectable)
 - Capable of setting a number of poles for UVW (Selectable from ×1,2,3,4)
 - Clock input (20MHz) : External CLK input / Crystal resonator / Ceramic resonator (Selectable)
 - Resolution of 10/12 bit (Selectable)

Outline

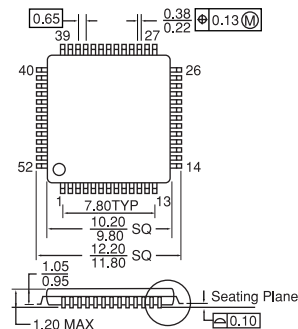

Specifications

Output form	Binary code parallel 10/12 bit bus compatible, positive logic	
Resolution	1,024 (2 ¹⁰)	4,096 (2 ¹²)
Tracking rate	240,000min ⁻¹	60,000min ⁻¹
Conversion accuracy	±2LSB	±4LSB (2 ¹)
Settling time (For step input of 180° in electric angle)	1ms Typ. (ACMD="H")	2.5ms Typ. (ACMD="H")
Response (As output response delay in electric angle)	±0.2° Max./10,000min ⁻¹	±0.4° Max./10,000min ⁻¹
2 phase pulse signal (A,B)	256C/T	1,024C/T
Source dissipation	DC5V±5% 45mA Max. (30mA Typ.)	
Operating temperature	-40~+125°C	
Storage temperature	-65~+150°C	
Humidity	90%Rh Max.	
Mass	1g Max.	

Functional Block Diagram

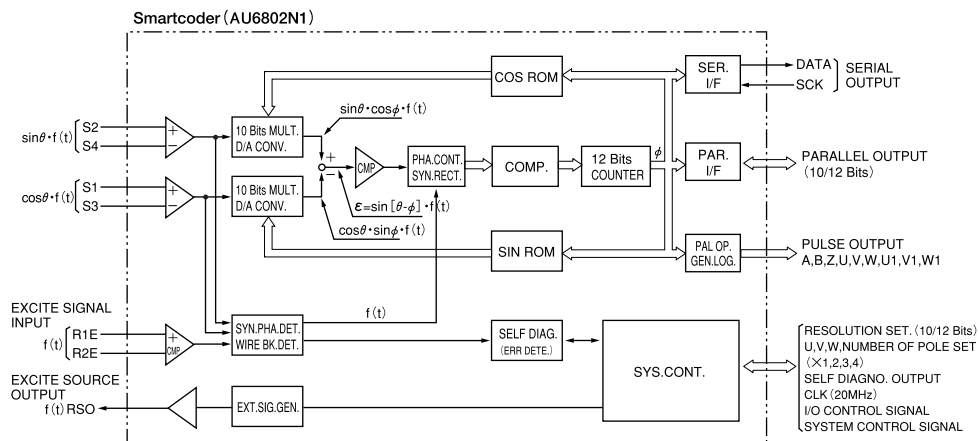

Pin Description

Pin No.	Symbol	Form	Function	Pin No.	Symbol	Form	Function	Pin No.	Symbol	Form	Function	Pin No.	Symbol	Form	Function
1	R1E	A/I	EXT.EXCIT.IP.	14	A GND	—	ANALOGUE GND	27	D0	D/O (BUS)	PRTY/φ12	40	D GND	—	DIGITAL GND
2	R2E	A/I	(DIF.IP.)	15	MDSEL	D/I	RES.SELECT	28	D1	D/O (BUS)	ERRHLD/φ11	41	CSB	D/I	CHIP SELECT
3	VCC	—	ANALOGUE SOURCE	16	ACMD	D/I	ACCEL.MODE CONTROL	29	D2	D/O (BUS)	ERR/φ10	42	RDB	D/I	LEAD
4	SINMNT	A/O	SIN.MONITOR	17	XSEL1	D/I	UVW P SEL.	30	D3	D/O (BUS)	W1/φ9	43	INHB (RD)	D/I	INHIBIT
5	S4	A/I	SIN.IP.	18	XSEL2	D/I		31	D4	D/O (BUS)	V1/φ8	44	PRTY	D/O (BUS)	PARITY
6	S2	A/I	(DIF.IP.)	19	OUTMD	D/I	OP.SEL	32	D5	D/O (BUS)	U1/φ7	45	ERRHLD	D/O	ERROR HOLD
7	A GND	—	ANALOGUE GND	20	SCSB	D/I	SERIAL CSB.	33	D GND	—	DIGITAL GND	46	ERRSTB	D/I	ERROR RESET
8	S1	A/I	COS.IP.	21	DATA	D/O	SERIAL DATA	34	D6	D/O (BUS)	Wch./φ6	47	FSEL1	D/I	FREQUENCY SELECT
9	S3	A/I	(DIF.IP.)	22	SCK	D/I	SERIAL LOCK	35	D7	D/O (BUS)	Vch./φ5	48	FSEL2	D/I	FREQUENCY SELECT
10	COSMNT	A/O	COS.MONITOR	23	VDD	—	DIGITAL SOURCE	36	D8	D/O (BUS)	Uch./φ4	49	VDD	—	DIGITAL SOURCE
11	VCC	—	ANALOGUE SOURCE	24	XTAL	—	OSC.CONN.	37	D9	D/O (BUS)	Zch./φ3	50	TEST1	D/I	TEST MODE SET
12	RSO	A/O	SIG.FOR EXCIT.	25	CLKIN	D/I	EXTERNAL CLK INPUT	38	D10	D/O (BUS)	Bch./φ2	51	TEST2	D/I	TEST MODE SET
13	COM	A/O	COMMON (2.5V)	26	D GND	—	DIGITAL GND	39	D11	D/O (BUS)	Ach./φ1	52	A GND	—	ANALOGUE GND

Note : *A/I ANALOG INPUT. *A/O ANALOG OUTPUT. *D/I DIGITAL INPUT. *D/O DIGITAL OUTPUT.

Connection of Smartcoder® (AU6802N1) to Resolvers

- ① The system to convert resolver signals (analog) to digital data is shown in the block diagram below.
- ② Please set the exciting source of a resolver to the exciting voltage / frequency specified in resolver specifications, by means of a buffer amplifier.
But when the specified voltage cannot be secured by reason of DC power source for the buffer amplifier, please refer to specifications of the Smartcoder. (Drawing No.801101411I40)
- ③ For details about connection of Smartcoder® (AU6802N1) , please refer to specifications of the Smartcoder. (Drawing No.801101411I40)

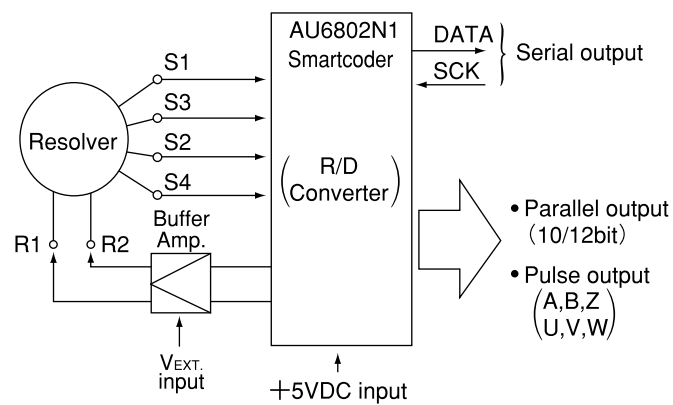

Installation of Resolvers

Attachment of resolvers (Singsyn®)

Ex. ① Attaching a resolver inside of a motor

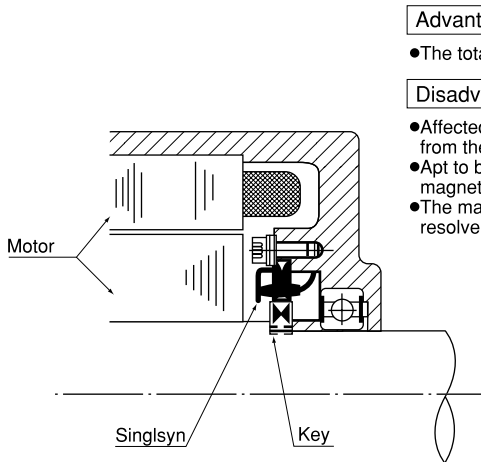

Advantage

- The total length can be shortened.

Disadvantage

- Affected greatly by the heat from the motor.
- Apt to be affected by the magnetic field of the motor.
- The maintenance of the resolver is not easy.

Ex. ② Attaching a resolver outside of a motor

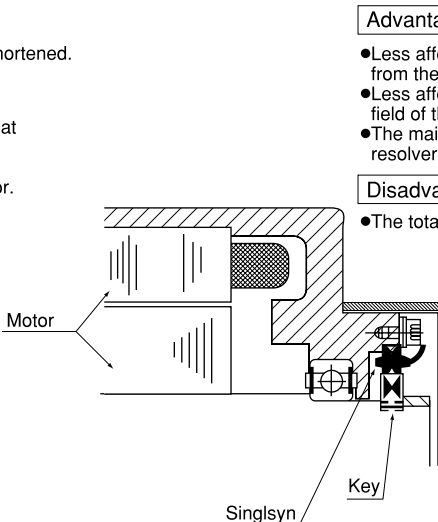

Advantage

- Less affected by the heat from the motor.
- Less affected by the magnetic field of the motor.
- The maintenance of the resolver is easy.

Disadvantage

- The total length is large.

Ex. ③ Attaching a resolver by use of magnetic shield-cum-fixing plate

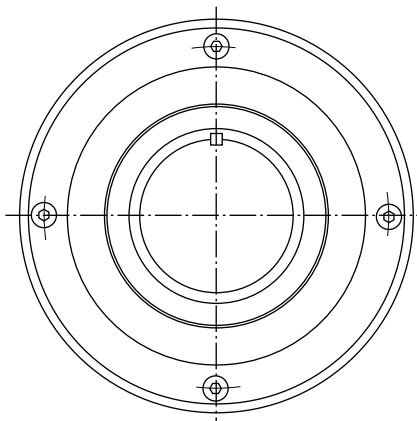
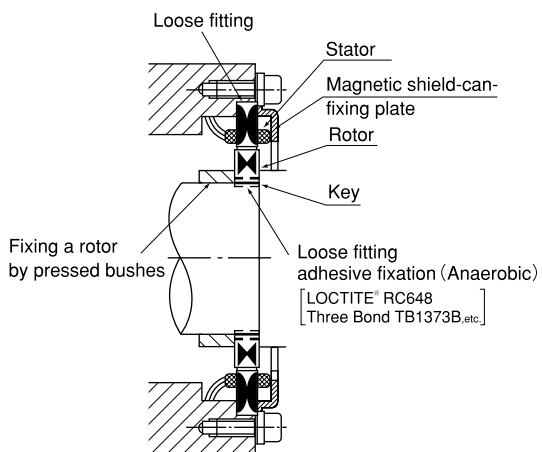

Ex. ④ Attaching a resolver by use of attaching nails

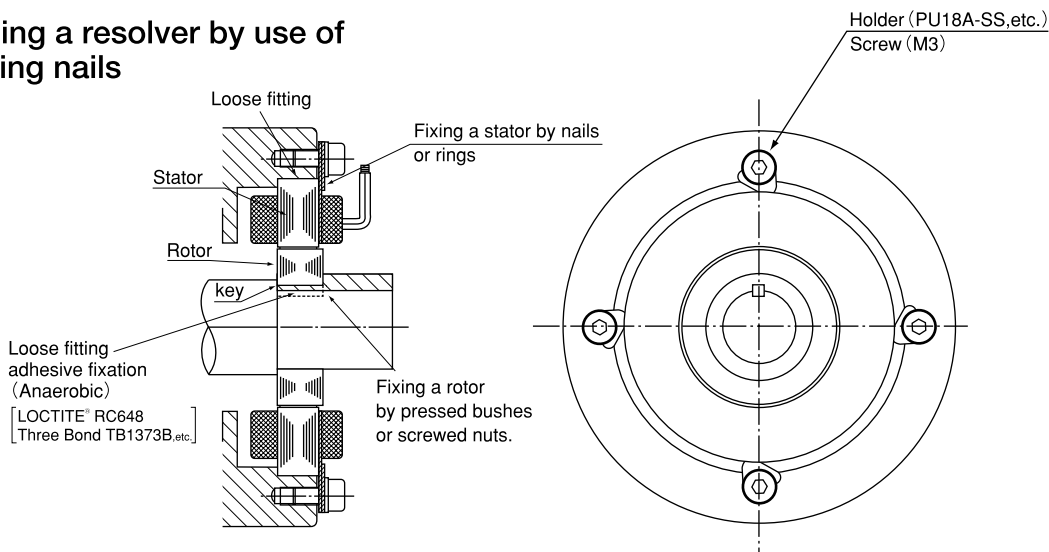

Attaching way of Resolvers (Smartsyn®)

① Groove Type

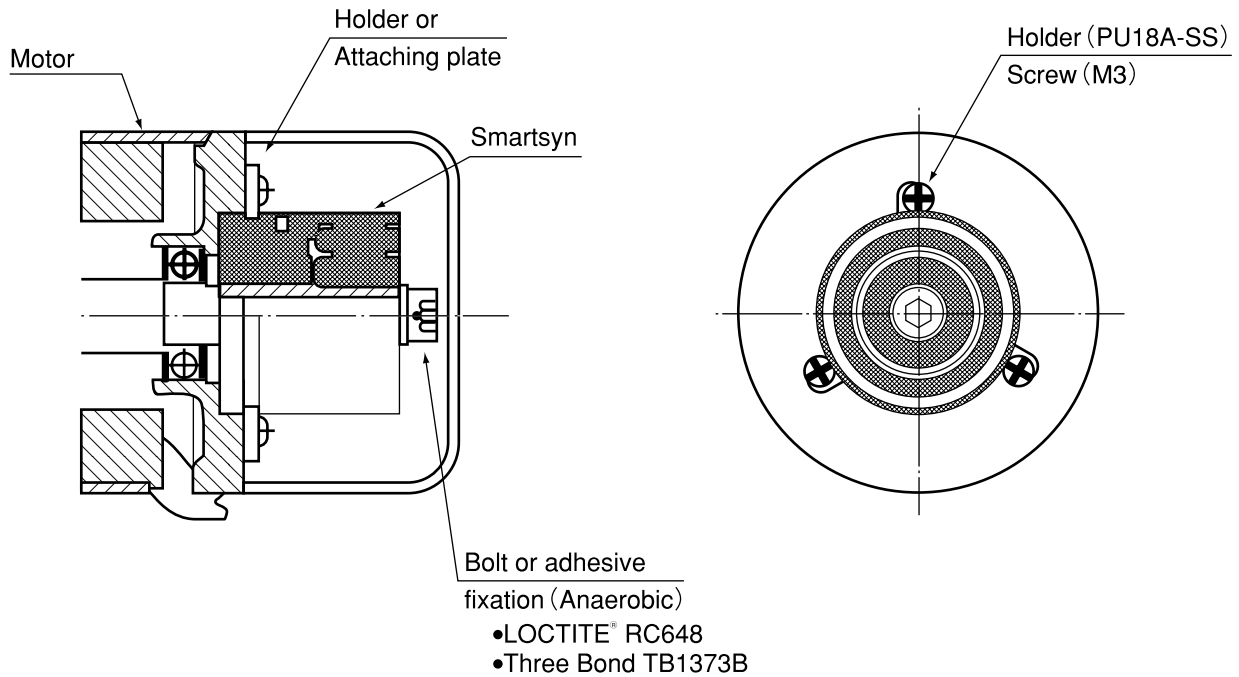

② Flange Type

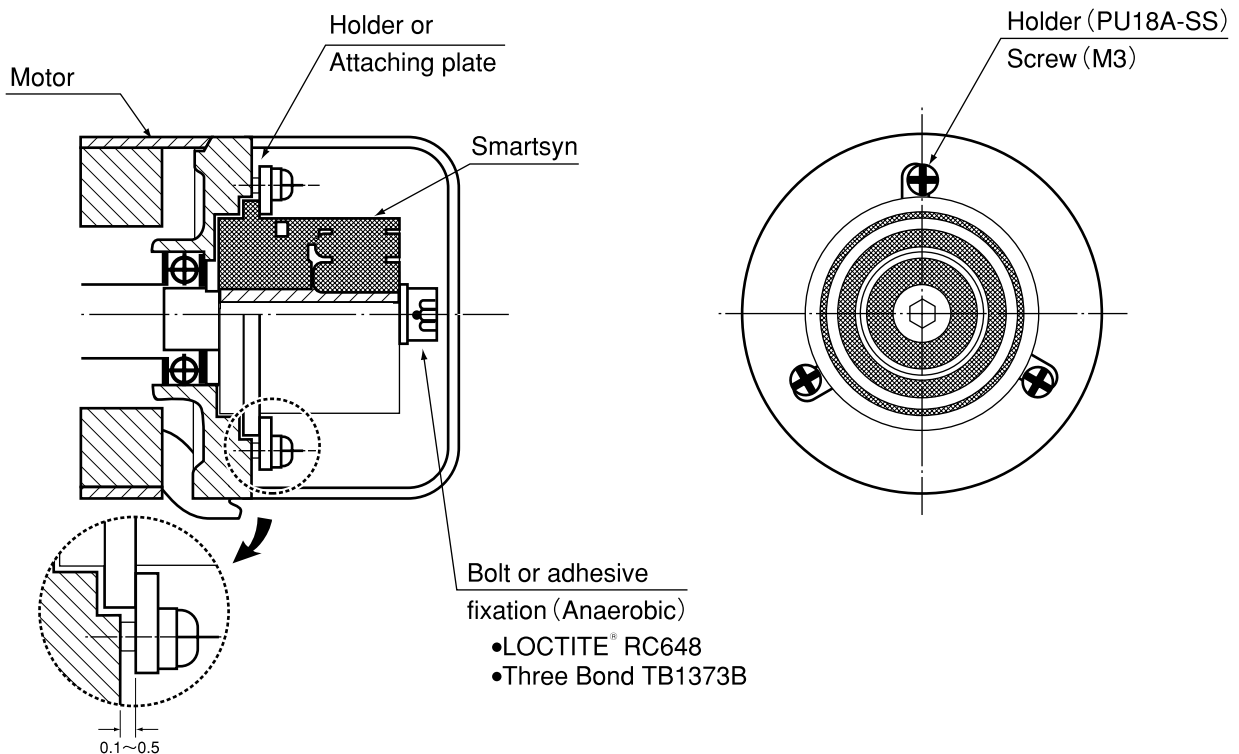

*Holders and screws are optional.

Notice in Handling Resolvers

A resolver is a precise instrument and it must be used with full understanding of safety notes to maximize its performance.

The following is the gist of safety precautions :

(1) Safety notes on unpacking

- ① After opening the package, check the appearance of the resolver for any abnormality.
- ② Do not touch coiled sections.
- ③ Do not carry or shake the resolver by the leads.
- ④ In carrying the resolver, be careful not to jar it because such a shock can cause malfunction.

(2) Safety notes on installation

- ① As to axial runout of a motor shaft, please refer to the mounting tolerances on page 23.
- ② Never use the resolver in the presence of corrosive gas or liquid.
- ③ Never use the resolver in the presence of radiation.
- ④ In installing the resolver, do not give forcible impact to it. Particularly do not hit the coiled sections.
- ⑤ In case of the presence of a strong external magnetic field around the resolver, it affects the magnetic flux in the resolver and may result in some electrical errors. In this case, please consider setting some shielding in the resolver.

(3) Safety notes on wiring

- ① In case of the presence of a large noise source in the vicinity or in case of a long transmission line, twisted pair lines with shield in each pair should basically be used.
- ② If the resolver is connected to imbalanced loads for each output of 2 phases, two output voltages become imbalanced and may result in some electric errors. Therefore, the loads of 2 phases should be in the same condition.

(4) Safety notes on pre-operation

- ① Please double-check if the stator and the rotor are firmly fixed.

(5) Safety notes on operation

- ① Be sure to use the resolver under the specified ambient temperature, relative humidity and rotating speed. If the resolver is used for a long time under the conditions that relative humidity is near 100%, the electrical insulation of the resolver may gradually deteriorate. In such a case, some protective cover for the resolver is recommended.
- ② Do not touch the rotating shaft.
- ③ Do not drop or splash any water or oil onto the products.
- ④ Consult us about the use of the encoder in a place with much vibration and shock.

Types and Designations of Protective Structure

1 . Designations of protective structures

Types of protective structures are designated with the symbol IP, First coding in Table1, and Second coding in Table2 in this order.

IP 3 0

Table1: Types of protective structures against entry of solids

First Coding	Protection Degree
3 (Semi totally-enclosed type)	Solids of 2.5mm or over in diameter do not enter inside.
4 (Totally-enclosed type)	Solids of 1.0mm or over in diameter do not enter inside.
5 (Dustproof type)	Dust that impairs the designed operation or safety of sensors do not enter inside.
6 (Dusttight type)	Dust particles do not enter inside.

Table2 : Types of protective structures against entry of water

Second Coding	Protection Degree
0 (Open type)	Not protected against entry of water.
2 (Drip-proof 2 type)	Subject to no harmful effects by waterdrops falling at angles 15° or less from vertical.
3 (Rain-proof type)	Subject to no harmful effects by waterdrops falling at angles 60° or less from vertical.
4 (Spray-proof type)	Subject to no harmful effects by water spray from any direction.
5 (Jet-proof type)	Subject to no harmful effects by water jets from any direction.
6 (Water-proof type)	Impervious to water in strong jets from any direction. (Note 1)
7 (Immersion-proof type)	No water entering when immersed under water at specified pressure for specified time.

Note (1) "Water-proof" means a structure that does not allow the entry of water against strong water jets from any directions, but it does not mean a structure that allows use under water.

Conversion Table

Binary Bit	Counts	degree	min	sec
7	128	2.8125	168.75	10125.00
8	256	1.40625	84.375	5062.50
9	512	0.703125	42.1875	2531.25
10	1,024	0.3515625	21.09375	1265.63
11	2,048	0.17578125	10.546875	632.81
12	4,096	0.087890625	5.2734375	316.41
13	8,192	0.043945313	2.63671875	158.20
14	16,384	0.021972656	1.318359375	79.10
15	32,768	0.010986328	0.659179688	39.55
16	65,536	0.005493164	0.329589844	19.78
17	131,072	0.002746582	0.164794922	9.89
18	262,144	0.001373291	0.082397461	4.94
19	524,288	0.000686646	0.041198730	2.47
20	1,048,576	0.000343323	0.020599365	1.24
21	2,097,152	0.000171661	0.010299683	0.62
22	4,194,304	0.000085831	0.005149841	0.31
23	8,388,608	0.000042915	0.002574921	0.15
24	16,777,216	0.000021458	0.001287460	0.08
25	33,554,432	0.000010729	0.000643730	0.04
26	67,108,864	0.000005364	0.000321865	0.019
27	134,217,728	0.000002682	0.000160933	0.010
28	268,435,456	0.000001341	0.000080466	0.005
29	536,870,912	0.000000671	0.000040233	0.002
30	1,073,741,824	0.000000335	0.000020117	0.001

Conversion Table

Concept of angles expressed in arc second

α	χ
10,000 arc sec (2.8degrees)	35m
1,000 arc sec (0.28degrees)	350m
100 arc sec (0.028degrees)	3.5km
10 arc sec	35km
2 arc sec	180km
1 arc sec	350km
0.6 arc sec	550km
0.5 arc sec	650km
0.1 arc sec	3,500km
0.01 arc sec	35,000km

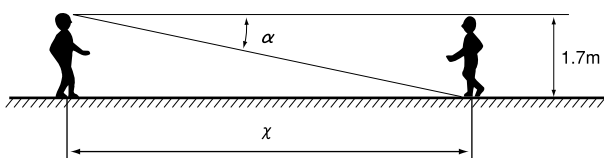



TAMAGAWA TRADING CO.,LTD.

A COMPANY OF TAMAGAWA SEIKI CO.,LTD.

HEADQUARTERS:

1879 OHYASUMI, IIDA, NAGANO PREF, 395-8515, JAPAN
PHONE : 0265-21-1800
FAX : 0265-21-1861

SALES OFFICE:

1020 KEGA, IIDA, NAGANO PREF, 395-8520, JAPAN
PHONE : 0265-56-5423
FAX : 0265-56-5427

TOKYO OFFICE:

3-19-9 SHINKAMATA, OHTA-KU, TOKYO, 144-0054, JAPAN
PHONE : 03-3738-3132
FAX : 03-3738-3175

WARRANTY

Tamagawa Seiki warrants that this product is free from defects in material or workmanship under normal use and service for a period of one year from the date of shipment from its factory. This warranty, however, excludes incidental and consequential damages caused by careless use of the product by the user. Even after the warranty period, Tamagawa Seiki offers repair service, with charge, in order to maintain the quality of the product. The MTBF (mean time between failures) of our product is quite long; yet, the predictable failure rate is not zero. The user is advised, therefore, that multiple safety means be incorporated in your system or product so as to prevent any consequential troubles resulting from the failure of our product.



●URL <http://www.tamagawa-seiki.co.jp>

Contact: **GROUP SIX**

800-433-3434 USA

All specifications are subject to change without notice.

04.7
email: info@grp6.com

TAMAGAWA SEIKI CO., LTD. 2004.7.1