

HIGH ACCURACY SINGLE AXIS MODULE SG SERIES

DIMENSIONS

●SG20

(Unit : mm)

With 1 long block : A (With 2 long blocks : B)

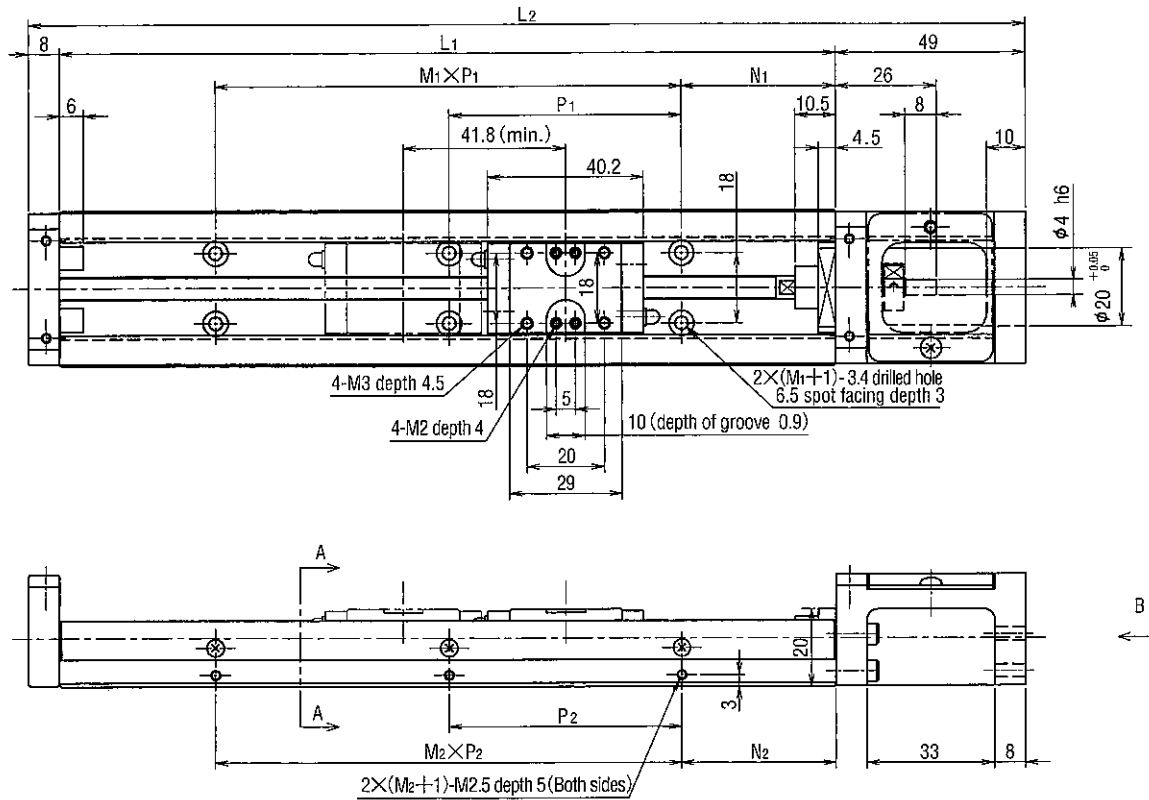

Without dustproof cover

Motor bracket configuration : A0

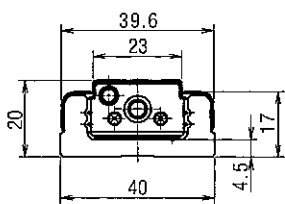

A-A sectional view

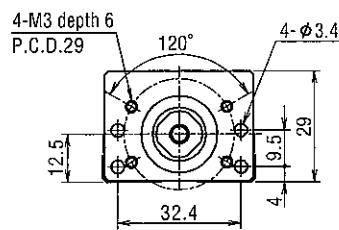

B view

HIGH ACCURACY SINGLE AXIS MODULE SG SERIES

DIMENSIONS

●SG20

(Unit : mm)

With dustproof cover and long block

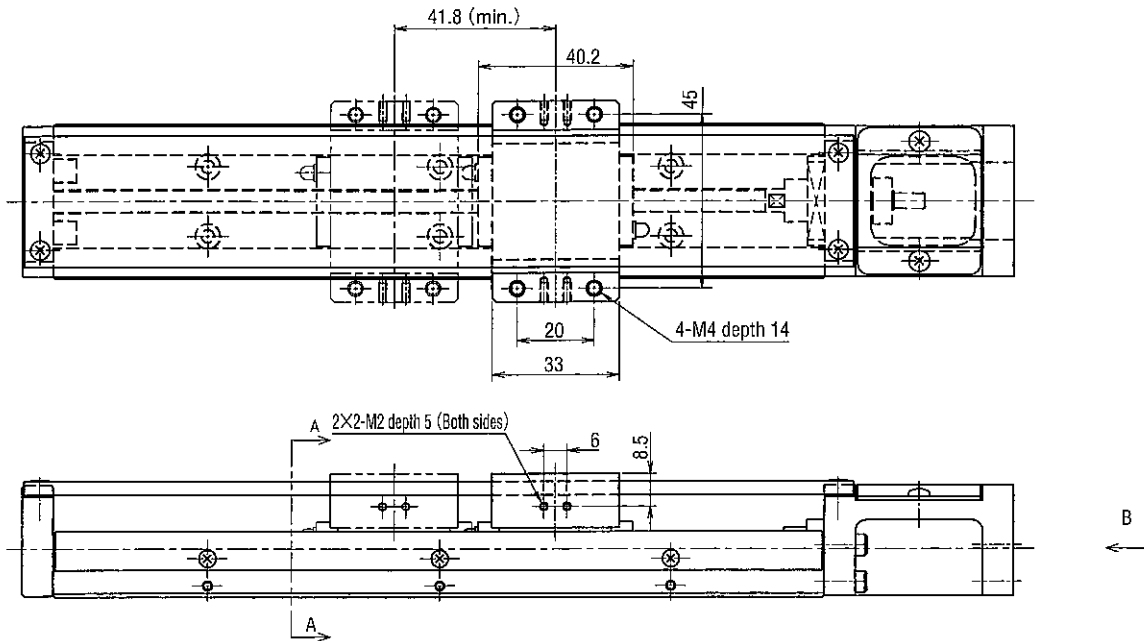

With dustproof cover

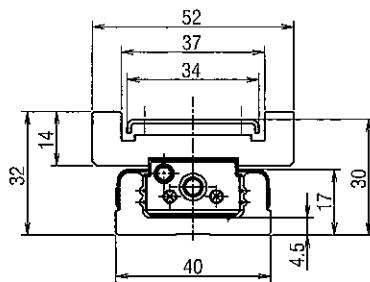

A-A sectional view

Motor bracket
configuration : A0

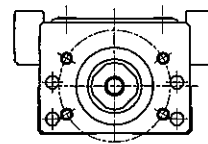

B view

Dimensions						Maximum stroke	
L_1	L_2	N_1	$M_1 \times P_1$	N_2	$M_2 \times P_2$	SG20□A	SG20□B
100	157	20	1×60	20	1×60	43	—
150	207	15	2×60	15	2×60	93	51
200	257	40		40		143	101

Maximum stroke : Traveling distance of slide block between urethane rubber

HIGH ACCURACY SINGLE AXIS MODULE SG SERIES

DIMENSIONS

●SG26

(Unit : mm)

With dustproof cover and long block

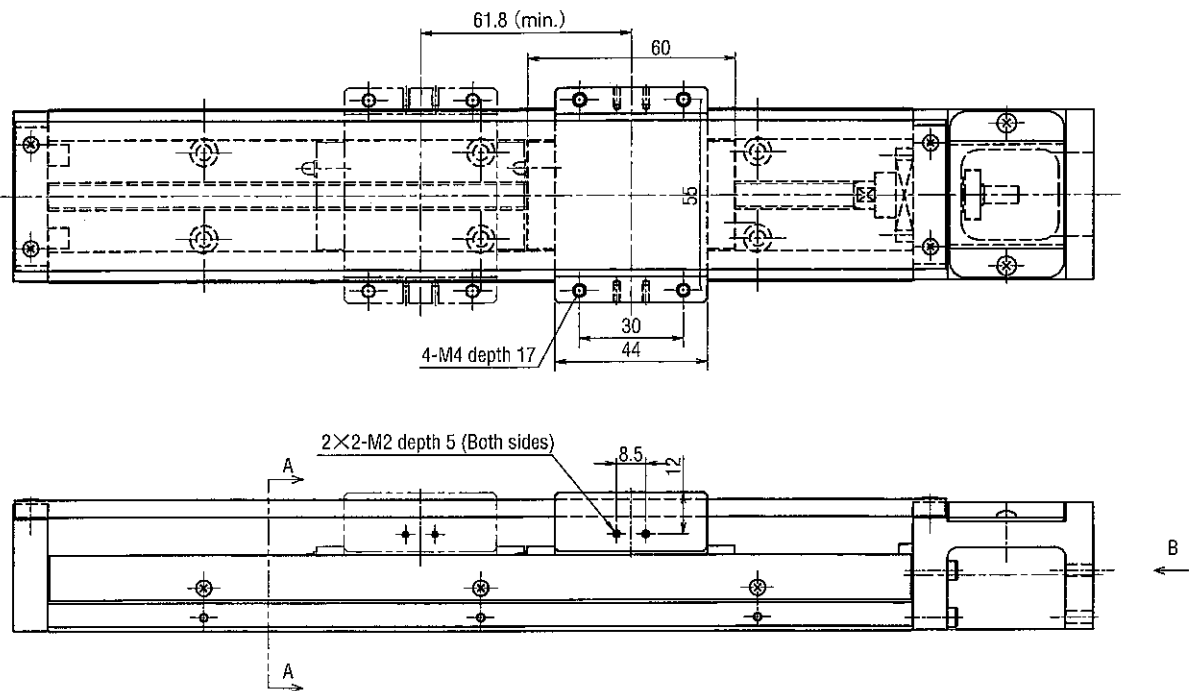

With dustproof cover

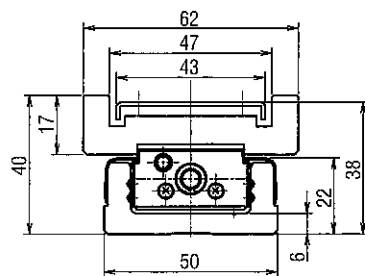

A-A sectional view

Motor bracket configuration : A0

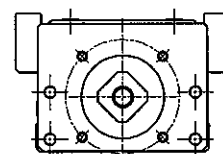

B view

Dimensions						Maximum stroke	
L_1	L_2	N_1	$M_1 \times P_1$	N_2	$M_2 \times P_2$	SG26□A	SG26□B
150	212	35	1×80	35	1×80	73	—
200	262	20	2×80	20	2×80	123	61
250	312	45		45		173	111
300	362	30	3×80	30	3×80	223	161

Maximum stroke : Traveling distance of slide block between urethane rubber

HIGH ACCURACY SINGLE AXIS MODULE SG SERIES

DIMENSIONS

●SG33

(Unit : mm)

With 1 short block : C (With 2 short blocks : D)

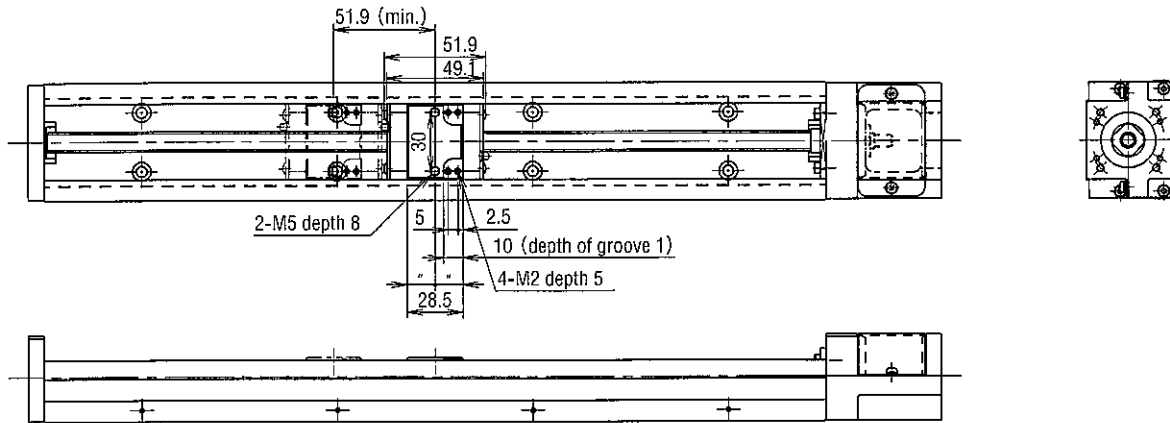

With dustproof cover and short block

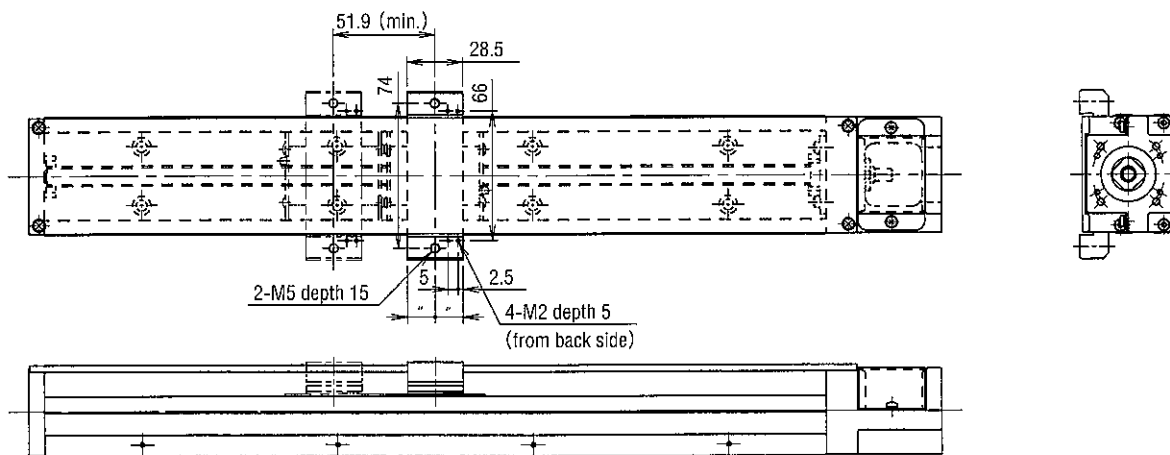

Dimensions						Maximum stroke			
L ₁	L ₂	N ₁	M ₁ × P ₁	N ₂	M ₂ × P ₂	SG33□A	SG33□B	SG33□C	SG33□D
150	217	25	1 × 100	25	1 × 100	60	—	85	34
200	267	50	1 × 100	50	1 × 100	110	—	135	84
300	367		2 × 100		2 × 100	210	133	235	184
400	467		3 × 100		3 × 100	310	233	335	284
500	567		4 × 100		4 × 100	410	333	435	384
600	667		5 × 100		4 × 100	510	433	535	484

Maximum stroke : Traveling distance of slide block between urethane rubber

HIGH ACCURACY SINGLE AXIS MODULE SG SERIES

DIMENSIONS

●SG46

(Unit : mm)

With 1 short block : C (With 2 short blocks : D)

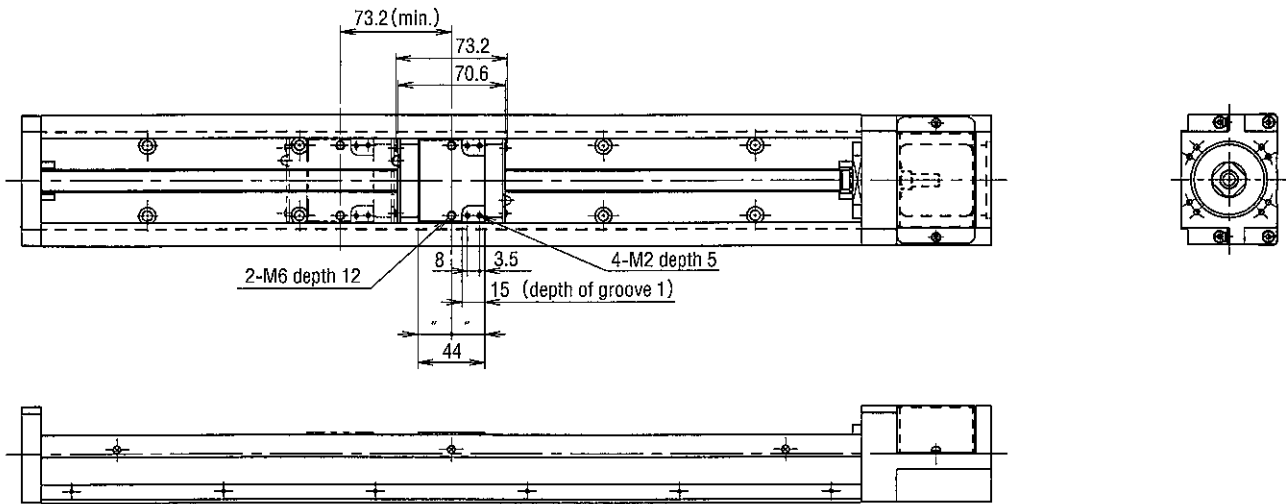

With dustproof cover and short block

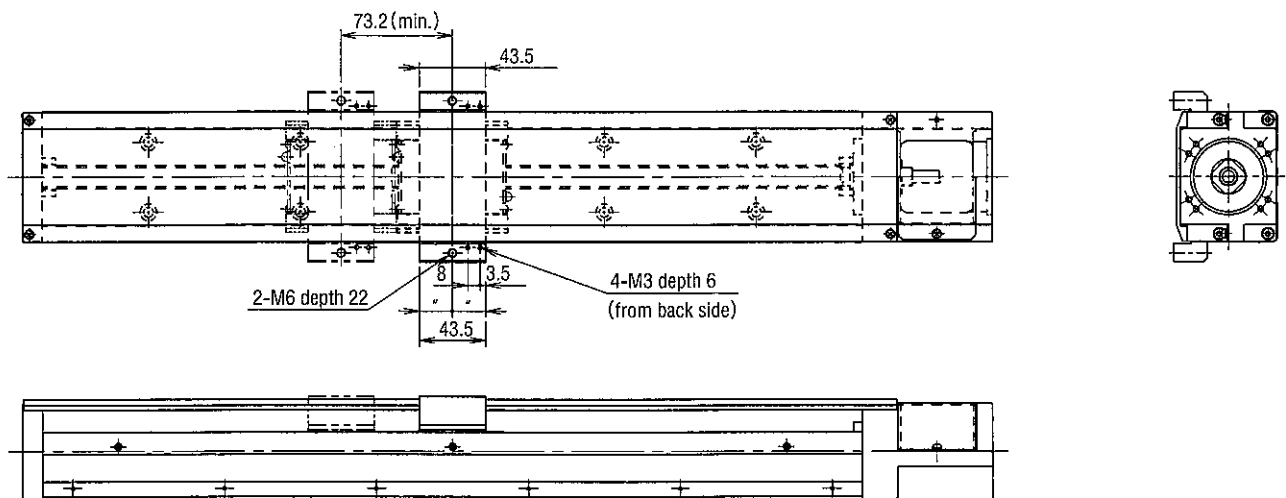

Dimensions						Maximum stroke			
L ₁	L ₂	N ₁	M ₁ × P ₁	N ₂	M ₂ × P ₂	SG46□A	SG46□B	SG46□C	SG46□D
340	438.5	70	2 × 100	20	3 × 100	209	100	245	172
440	538.5		3 × 100		4 × 100	309	200	345	272
540	638.5		4 × 100		5 × 100	409	300	445	372
640	738.5		5 × 100		6 × 100	509	400	545	472
740	838.5		6 × 100		7 × 100	609	500	645	572
840	938.5		7 × 100		8 × 100	709	600	745	672
940	1038.5		8 × 100		9 × 100	809	700	845	772

Maximum stroke : Traveling distance of slide block between urethane rubber

HIGH ACCURACY SINGLE AXIS MODULE SG SERIES

DIMENSIONS

●SG55

(Unit : mm)

With 1 long block : A (With 2 long blocks : B)

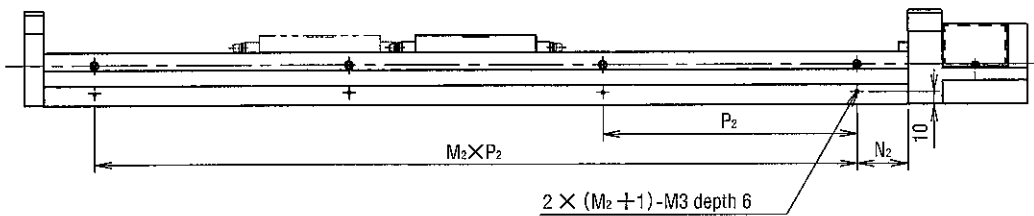
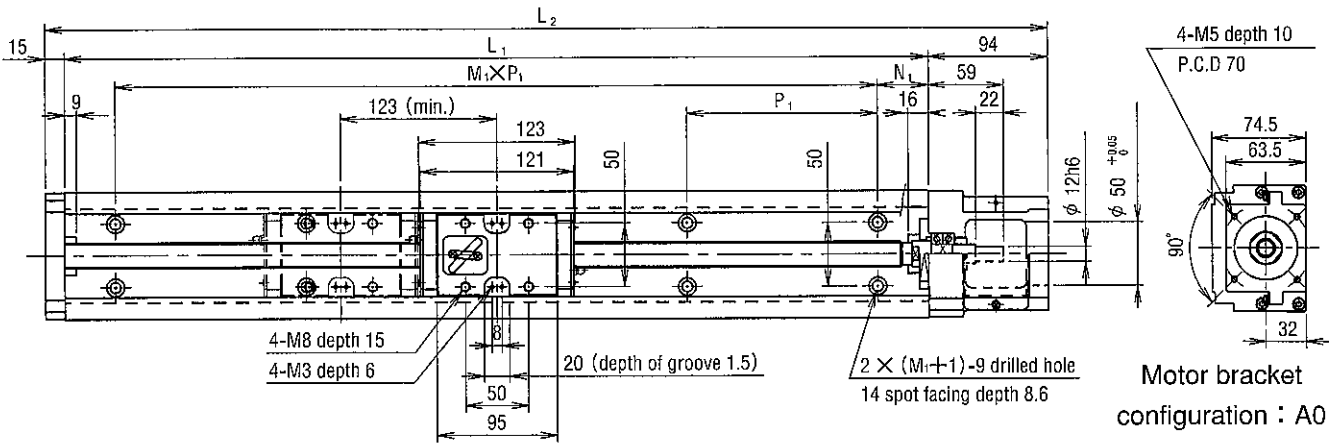

Without dustproof cover

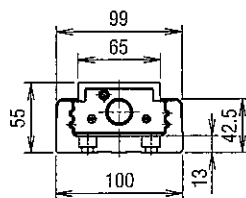

HIGH ACCURACY SINGLE AXIS MODULE SG SERIES

DIMENSIONS

●SG55

(Unit : mm)

With dustproof cover and long block

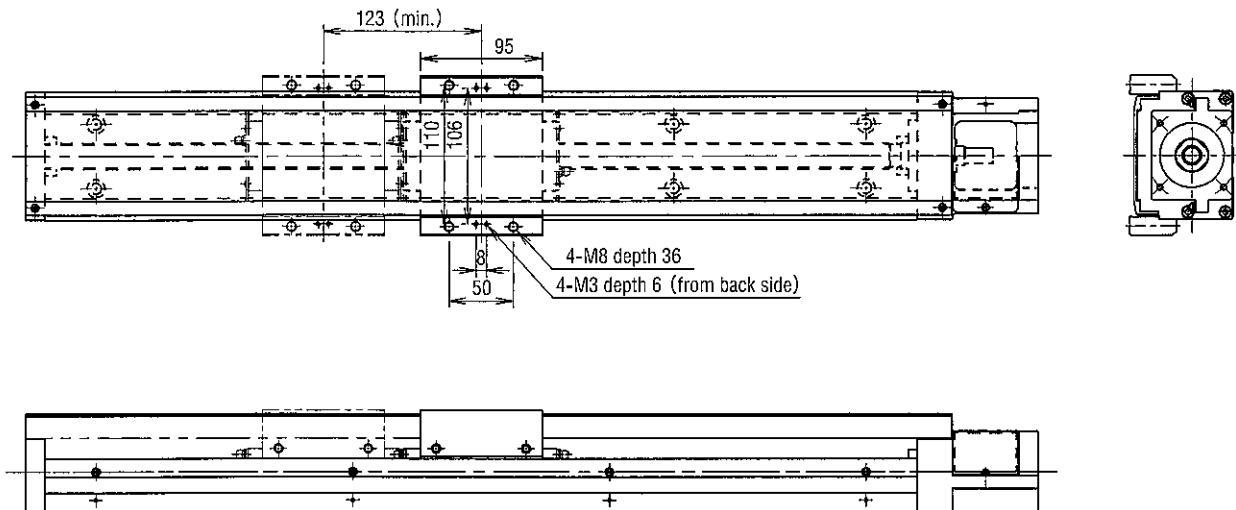

With dustproof cover

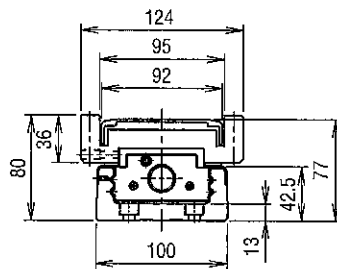

Dimensions						Maximum stroke	
L ₁	L ₂	N ₁	M ₁ × P ₁	N ₂	M ₂ × P ₂	SG55□A	SG55□B
980	1089	40	6 × 150	90	4 × 200	834	711
1080	1189	15	7 × 150	40	5 × 200	934	811
1180	1289	65		90		1034	911
1280	1389	40	8 × 150	40	6 × 200	1134	1011
1380	1489	15	9 × 150	90		1234	1111

Maximum stroke : Traveling distance of slide block between urethane rubber