

Installing Tecnotion Ironless Linear Motors



TECNOTION

TECNOTION B.V.
PO BOX 23
7600 AA ALMELO
THE NETHERLANDS
Document nr. 4022.363.4193.2
Version 2.3
Issue Date: October 2007

Contents

Co

Contents

Contents.....	1
Introduction	2
1. Before you start	3
1.1. Important notice	3
1.2. Safety warnings	4
1.3. EC declaration	5
2. Components	6
2.1. Basic components	7
2.2. Additional Features	8
2.2.1. Bolts and dowel pins.....	9
2.2.2. Controller and measurement unit	10
2.2.3. Tools.....	10
3. Installation	11
3.1. Installation order	12
3.2. Requirements for the mounting surfaces	14
3.3. Magnet track mounting instructions.....	16
3.4. Coil unit mounting instructions.....	18
3.5. Electrical Connections.....	19
3.5.1. General remarks	19
3.5.2. Power lines.....	21
3.5.3. Protective earth.....	21
3.5.4. Temperature Sensor	22
3.5.5. Temperature protection	22
3.5.6. PTC specification.....	22
3.5.7. KTY specification	23
3.5.8. Polarization test	24
4. Operation	26
4.1. General	26
4.2. Configuring.....	27
4.3. Testing	28
4.3.1. End switches.....	28
4.4. Starting up.....	29
4.5. Optimization of control settings.....	29

Intro

I

Introduction

Generally a linear motor system is a part of a specific machine. Tecnotion's linear motors can be combined with numerous application devices. This installation manual is intended for those technicians who construct a machine that includes a linear motor system

When installing a linear motor system one should be familiar with some important safety remarks. In the first chapter these remarks are made. Please, read them carefully.

Besides mounting the coil unit and the magnet plates, the installation includes the electrical wiring and the connections between the motor and the servo-controller.

Before starting up, some required settings will be discussed. Finally your linear motor can take off for it's first ride.

For further information and support, please contact:

TECNOTION B.V. PO Box 23 7600 AA Almelo The Netherlands	Telephone: +31(0)546 534 690 Fax: +31(0)546 534 699 sales@tecnotion.com www.tecnotion.com
--	--

Chapter

Ch

1. Before you start

Please read the following instructions very carefully. They are important for a safe and warranted installation and operation of the Linear Motor.

1.1. Important notice



Before installing and using the Linear Motor, read this instruction manual carefully. The manufacturer declines all responsibility in case of accident or damage due to negligence or lack of observance of the instructions described in this manual. The manufacturer also declines all responsibility in case of accident or damage in conditions that differ from those indicated in the manual; Tecnotion also declines all responsibility for damage caused by improper use of the Linear Motor.



Handle the components of the Linear Motor with care, packed as well as unpacked. Especially the magnet yokes are sensitive to mechanical shocks. Never drop a magnet yoke or release it in an uncontrolled way. Do not expose the magnets to temperatures higher than 70° C. The magnets may be demagnetized at higher temperatures.



Unpack the Linear Motor and check its integrity. If there is any irregularity, contact the dealer or manufacturer, signalling the nature of the defects. Make a note of the serial number. This facilitates the correspondence with the supplier.

1.2. Safety warnings



The Linear Motor is used as a part of a machine. The user has to take care that the machine as a whole fulfils all CE requirements.



The magnet yokes contain a strong magnetic field. Lose iron objects that are brought within 5cm of the yokes, can be drawn into the yokes and cause damage.

Magnetic sensitive objects like banking cards or other magnetic information carriers may be damaged if they are brought within 10cm of the magnet yokes.



The magnet yokes do attract each other while mounting. Take care that the closing plates of one yoke do not damage the magnets of the neighbour magnet yoke while mounting.



If at any time and in any situation there is any doubt about the safety of the Linear Motor, do not use it and contact your supplier.



The Linear Motor is powered by a servo amplifier. In case of a power disruption or fatal error this may automatically result in a free run out of the motor. Make mechanical precautions to prevent damage on the motor or your machine in the case of such an event.



Before installing the motor, make sure that the supply mains are grounded and operate in conformity with the regulations in force.



Make sure that there is an effective protective earth. Make sure that there is no voltage at the line wire terminals before connecting.



An earth connection does not work on non-conducting mounting surfaces like granite. In these cases the protective earth must be established by an earthing wire



Before carrying out checks or doing any maintenance, clear the system by disconnecting the voltage. Be sure that there is no possibility of accidental connections.

1.3. EC declaration

Tecnotion B.V. declares that the all linear motors produced by Tecnotion are manufactured in accordance with the applicable European directives and in conformity with the following standards:

Standard #	Date of issue	Name of Standard
EN 60034	05-1998	Rotating electrical machines
EN 60204 (-1)	02-1995	Safety of machinery
EN 50081-2	08-1993	Emission requirements for products in an industrial environment
EN 50082-2	03-1995	Immunity requirements for products in an industrial environment

Chapter
Ch

2. Components

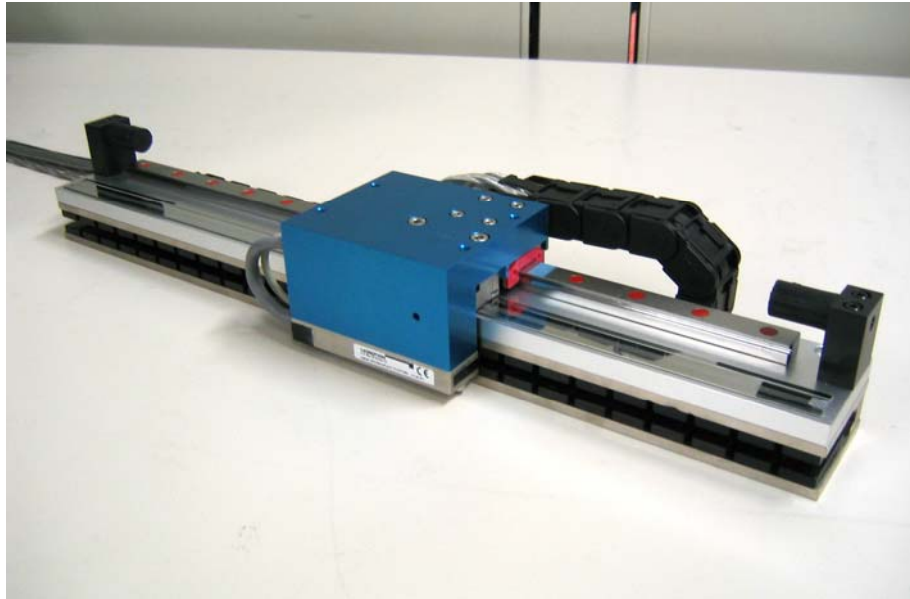

Figure 1: A complete ironless linear motor system

An ironless linear motor of Tecnotion is not a system on itself. It contains several components, such as a coil unit and magnet yokes. The components should be built within a total machine concept or a working unit. The size and the shape of the mounting frame, the design of the slide, the type bearings or the kind of dampers depend of the required application. For instance the mounting frame and the slide should be designed in such a way that a correct air gap between coil unit and magnet yokes will be obtained.

Tecnotion provides standard and special components which are suitable for numerous linear motor applications. These components can easily be applied in your system.

2.1. Basic components

The basic Linear Motor components supplied by Tecnotion are:

- The coil unit (the N and S version differing in voltage and current requirements)

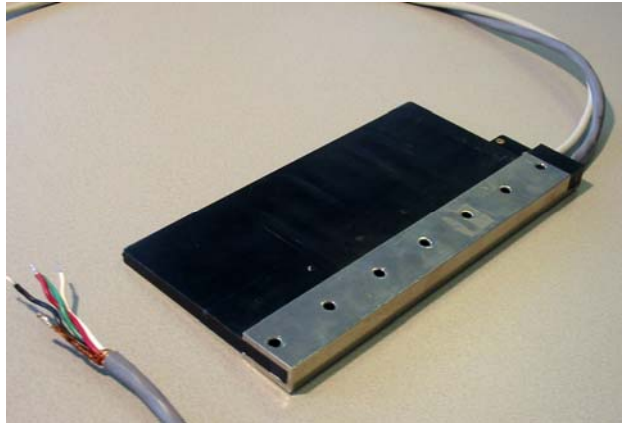

Figure 2: Coil unit

- The magnet yoke (in different lengths, varying in outer dimensions and mounting)

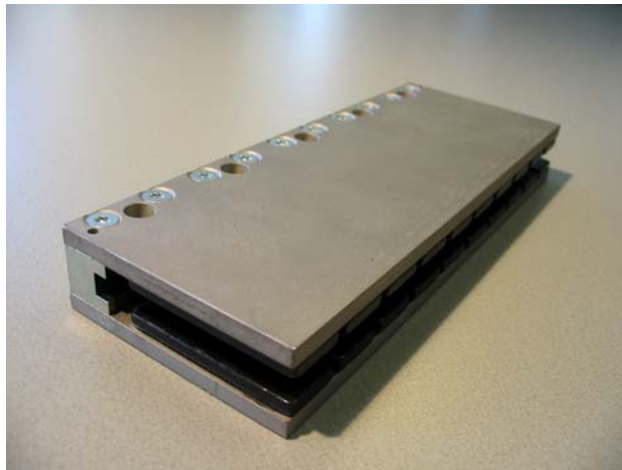

Figure 3: Magnet yoke



Before starting the installation, check the presence of the right number and type of the delivered components. In case of doubt, please contact Tecnotion immediately.

2.2. Additional Features

For a proper installation of your linear motor system you also need

- fixing components, like bolts and pins;
- additional devices, like a servo controller and a linear encoder;
- the right tools.

These features are no part of Tecnotion's standard delivery. If desired Tecnotion can supply all additional components as well as some types of devices.

2.2.1. Bolts and dowel pins



Figure 4: Dowel pins

The following bolts and dowel pins are required for positioning and fixing the coil unit to the slide as well as connecting the magnet yokes to the mounting frame:

Features	UM	UL	UXX
Bolts for coil unit (steel)	M3x16, DIN912	M4x20, DIN912	M5x20, DIN912
Bolts for magnet yoke (steel)	M4x25, DIN912	M5x35, DIN912	M6x50, DIN912
Dowel pins for magnet yoke (optional)	3h8, DIN7		

Features	UC
Bolts for coil unit (steel)	M3, DIN912, Class 12.9
Tightening torque	1.0 - 2.0 Nm
Dept bolt in threath hole	Top: through coil unit Side: 1.5 – 2.8mm
Bolts for magnet yoke (steel)	M4x20, DIN7984
Dowel pins for magnet yoke (optional)	3h8, DIN7

2.2.2. Controller and measurement unit

Required is:

- An appropriate servo controller/amplifier
- A ruler and a linear encoder or an analogue Hall module
- Power supply, cabling and connectors

For more information please contact Tecnotion.

2.2.3. Tools

Necessary for the installation is:

- Allen Key set

Occasionally useful are:

- Heat sink compound (optional)
- Wipes to clean mounting surfaces

Chapter
Ch

3. Installation



3.1. Installation order

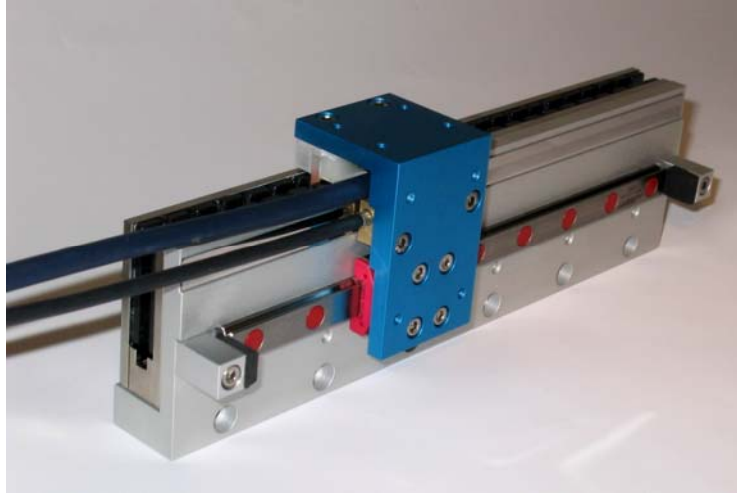

Figure 5: Ironless linear motor system

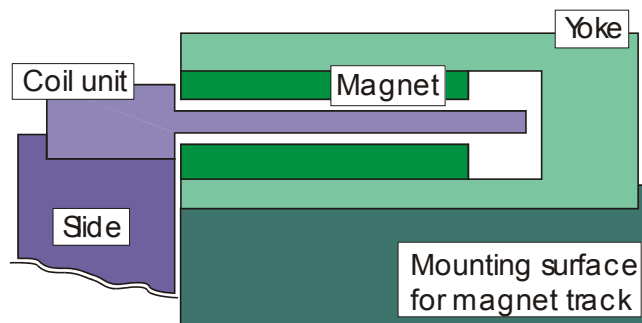

Figure 6: Coil unit, slide, magnet yoke and mounting surface, schematically



The installation order of this instruction manual must be followed. A different order may cause damage to your machine.

Before installing the Linear Motor components, the installation of the mounting frame should be completed. The slide should be provided with bearings, dampers, linear probe and required cabling in such a way that a smooth, save and well positioned transport of the slide over the stroke is established. The ruler should be properly positioned and fixed to the frame. The operation of bearings and dampers should be tested as well as the guidance of the moving cables.

The correct installation order is for electrical safety reasons:

1. Mount the magnet yokes to the mounting surface of the machine.
2. Mount the coil unit to the involved machine parts
3. Connect the wiring to the coil unit.

From a magnetical point of view the installation order of the mechanics is not critical, because no attraction is present between the coil unit and magnet yokes.

The de-installation order is:

1. Disconnect the wiring from the coil unit.
2. Dismount the coil unit from the machine parts.
3. Dismount the magnet yokes from the machine's mounting surface

Before mounting the Linear Motor, special attention must be paid tot the mounting surface of the motor.

3.2. Requirements for the mounting surfaces

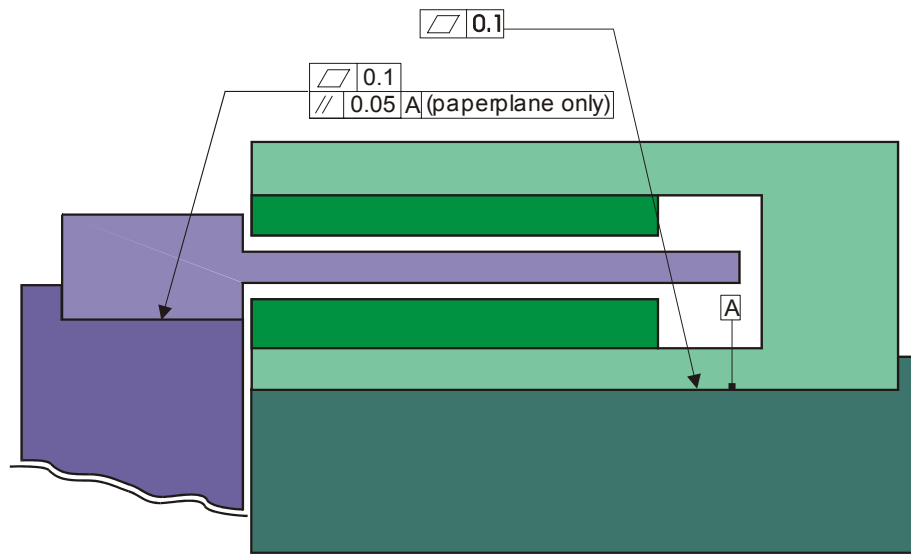

Figure 7: Flatness and parallelism of mounting surfaces, schematically

The mounting surfaces of both magnet yokes and coil units have to be flat to prevent them from being submitted to bending forces.

Specifications:

- Surface for coil unit having a flatness better than 0.1mm.
- Surface for the track of magnet yokes having a flatness better than 0.1mm.

The track of the magnet yokes – from now on to be called the *magnet track* – and the coil unit have to be aligned with respect to each other. Note that this has to be accomplished by the machine's construction.

To guarantee a non-contact running, the mounting surfaces of coil unit and the magnet track must be parallel:

- Parallelism of both surfaces better than 0.05mm in the plane perpendicular to the travelling direction.

To prevent disturbance forces, the axial direction of both components should be parallel. This has to be accomplished by supporting axial references for both the coil unit and the magnet yokes.

- axial references for both coil unit and magnet track with parallelism better than 0.2mm.

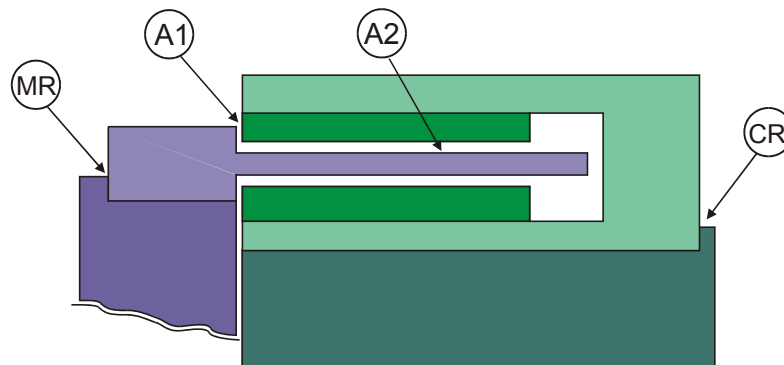

Figure 8: Air gaps and axial references, schematically

Axial reference for the magnet track (MR, see figure above) can be obtained by the use of

- dowel pins in the middle yoke of a short track,
- dowel pins along the complete side of a long track,
- milled reference along complete side of a long track (inner radius < 0.2mm), or
- alignment by hand during mounting.

Axial reference for the coil unit (CR) is obtained by

- two dowel pins beside the first and last bolt of the coil unit,
- milled reference along complete side (inner radius < 0.2mm), or
- alignment by hand during mounting.

Note that only when the right references and dimensions are applied the right dimensioned air gaps (A1 and A2) will be obtained. The dimensions of the coil units and magnet yokes can be found on the internet site of Tecnotion: www.tecnotion.com.

3.3. Magnet track mounting instructions



Especially the magnet yokes must be handled with care. They are sensitive to mechanical shocks. Never drop a magnet yoke or release it in an uncontrolled way!



Be sure that the mounting surfaces are free of contamination. Particles > 0.1mm can cause inaccurate placement and consequently damage to your Linear Motor.



The magnet yokes contain a strong magnetic field. Lose iron objects that are brought within 5cm of the yokes, can be drawn into the yokes and cause damage.

Magnetic sensitive objects like banking cards or other magnetic information carriers may be damaged if they are brought within 10cm of the magnet yokes.



The magnet yokes do attract each other while mounting. Take care that the closing plates of one yoke do not damage the magnets of the neighbour magnet yoke while mounting.

It is recommended to start the mounting of the magnet track with the middle – and preferably the longest – magnet yoke. This middle yoke can be aligned using the 3mm dowel pins or a milled reference.

Fix the magnet yoke on the mounting surface with bolts using the prescribed tightening torque.

The following yokes can be mounted with mechanical contact using the mutual attraction force of the magnet yokes.



Take care: apply the principle of controlled rotational mounting. Uncontrolled approach may cause damage to the magnets (see Figure 9).

Because a straight forward directing and placing of the yokes implies the risk of striking due to magnetical forces (as well as the risk of damaged magnets), the principle of rotational mounting is recommended here.



Figure 9: Principle of controlled rotational mounting of the magnet yokes

The next magnet yokes should not be aligned on dowel pins. Using a track of pins has namely two disadvantages:

1. In that situation rotational mounting is difficult.
2. Mounting can be impossible because of tolerances. The yokes are designed for a contact mounting without guaranteed gap between them.

Using a milled axial reference is advised for placement of the next tracks (longer than 200mm).

Placement of just one yoke on each side of the middle yoke can be done by simply aligning the yokes with respect to each other.

There is no danger of mounting the magnet yokes with an incorrect orientation, they are "Murphy-safe". A 180° rotated yoke does not have any effect on the motor function.

3.4. Coil unit mounting instructions



Be sure that the mounting surfaces are free of contamination. Particles > 0.1mm can cause inaccurate placement and consequently damage to your Linear Motor.

The mounting of the coil unit on appropriate and clean mounting surfaces is very straightforward because no attraction forces are present between coil unit and magnet yokes.

The coil unit can be placed into the machine by hand carefully, pushed to the axial reference and fixed with bolts. Tightening torque of the bolts as prescribed.



For applications which are susceptible to vibrations, the bolts have to be secured against loosening by means of rings or (Loctite) thread lock.



In case of high continuous forces, apply a heatsink compound to obtain optimal thermal contact between the coil unit and the mounting surface.

3.5. Electrical Connections



Before starting any activity on the wiring, make sure that the mains are disconnected.

Work carefully according the instructions belonging to the applied servo controller. Be sure your machine as a whole meets the requirements of all applicable electrical standards, such as the EN 60204 standard.

3.5.1. General remarks

The linear motor's electrical wiring is externally configured with two 1.0 meter cables: a power cable and a temperature cable. If desired you can shorten these cables and provide them with appropriate connectors.

Both power cable and temperature cable are shielded with a plaited metal cable sheath for electromagnetic immunity.

Besides this manual you should follow carefully the installation instructions of your servo amplifier supplier. Make sure that the linear motor system as a whole meets all the applicable electrical directives.

For wiring scheme of the UM, UL and UXX series see figure 10 below. The wiring scheme of the UC type is shown in figure 11.

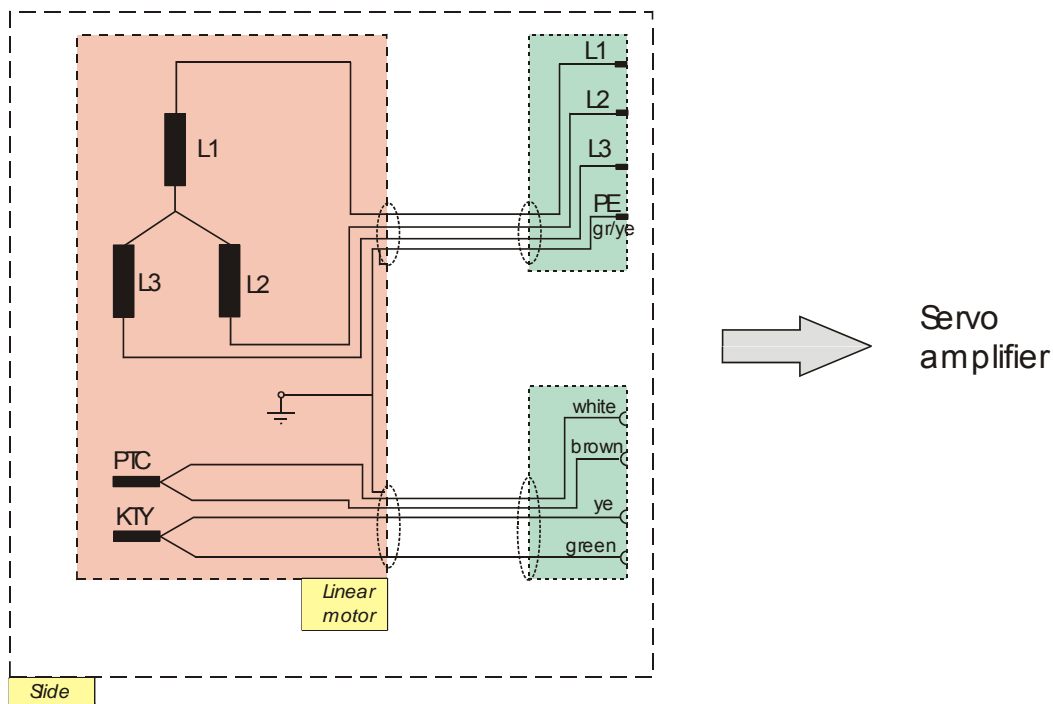

Figure 10: Wiring scheme UM, UL and UXX series ironless

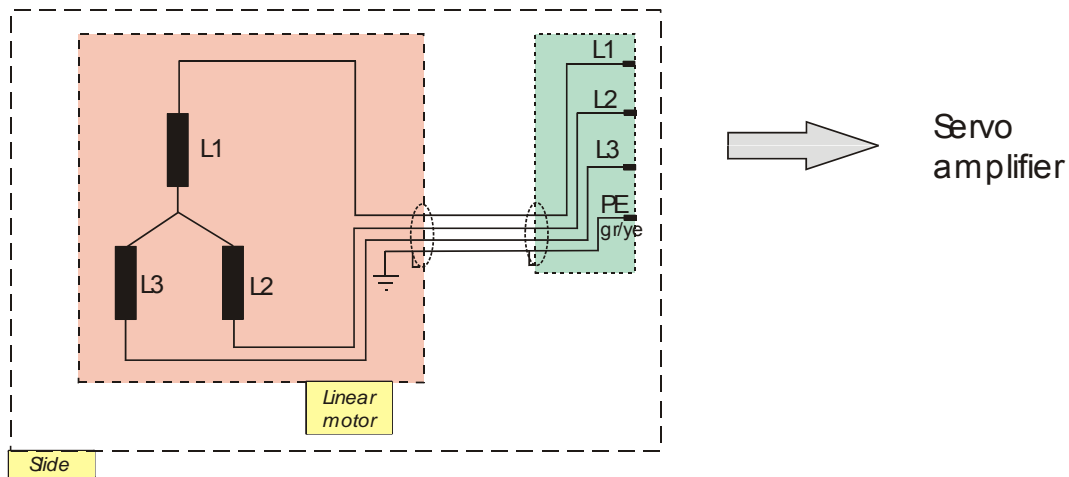

Figure 11: Wiring scheme UC series ironless

3.5.2. Power lines

The three phases of the motor's power cable have to be connected to the servo amplifier in such a way that the positive three phase direction of the motor conforms the positive direction of the linear encoder. This polarization has to be tested, it cannot be seen at first sight.



Testing the polarization is very important, because a wrong polarization will result in an uncontrolled run out of the slide.

The power cable can be confectioned by the user to fit on the servo drive. For moving cables it is advised to make the moving parts replaceable. This can be done by making a connection of the coil unit cable to the moving cable on the slide.

Powerlines		Color – UC, UM, UL and UXX	Connection to servo controller
3-phases	L1	black	3-phases
	L2	red	
	L3	white	
Protective Earth		green	Protective Earth
Shield			(Protective) Earth

3.5.3. Protective earth

Be sure that the earth shield of the cable is well connected – also through the connecting devices – to the PE connector or the housing of the amplifier. Most TL linear motors are driven on the principle of *pulse width modulation*. This involves large electrical impulses and causes a significant risk of electromagnetical interference.

Internally the motor's PE wire (green/yellow) is galvanic connected to the motor housing. This wire must be connected to the PE connector of the servo amplifier. Provide the motor system with PE lines to the amplifier that are as short as possible.

3.5.4. Temperature Sensor

The coil unit of the ironless Linear Motors – except for the UC series – is equipped with two temperature sensors, one of the PTC-1k-type and one of the KTY21-6 type. The PTC resistor is the motor’s standard device for checking the heat production in the coil unit.

The temperature cable consists of four wires. For wire color and function, see table below.

Sensor Lines (color)	Connection to servo controller
PTC (white)	PTC
PTC (brown)	PTC
KTY21 (green)	KTY21-6
KTY21 (yellow)	KTY21-6
Shield	Protective Earth



Attention: In mid-2008 the KTY-sensor will be replaced by a newer type. For more information please contact Tecnotion.

3.5.5. Temperature protection

The temperature sensors are normally used for overheating protection of the coil unit. The KTY-sensor can be used for monitoring temperature, PTC can be used a switch when maximal temperature is exceeded. For specifications and behavior see the next two paragraphs.

In some cases where long peak current are demanded, the thermal response time of the coil unit is too long to ensure a proper overheating protection of the sensors. This can occur for example during an accidental run or by taking a new axis in control.

In this case a I^2t protection can be used to prevent the coil unit from overheating. In almost all controllers an I^2t -protection can be set in the software. We can ensure proper protection of the temperature sensors up to an Irms of 25% of the ultimate current(20°C/s) of the motor.

For more information contact Tecnotion’s Application support team.

3.5.6. PTC specification

The PTC-1k type is a sensor which has a very sudden resistance rise near the critical temperature of the coils. It is almost a digital indicator: temperature below vs. over critical temperature. Therefore it is very

useful for signaling over temperature without requiring sensitive electronics. Disadvantage is that it is not possible to obtain a temperate signal.

At room temperature the PTC has an electrical resistance of about 65 Ohms. When the temperature raises to the critical temperature the resistance will increase rather uniformly up to 1000 Ohms. Above this temperature the resistance increases exponentially. Now, 1000 Ohms is the switching resistance. The amplifier should immediately stop the power supply when this resistance is exceeded. In this way overheating and motor damage can be prevented. No need to say that the PTC cable must be connected properly to the amplifier.

Temperature	Resistance
Up to 20°C below critical temperature	< 250 Ω
Up to 5°C below critical temperature	< 550 Ω
Nominal switching resistance	1000 Ω
Above critical temperature	> 1330 Ω

3.5.7. KTY specification

The KTY 21 has a rather stable and slow temperature coefficient. It can supply a temperature reading in the whole range. Therefore it is useful to monitor the coil temperature during tests and to decide whether the thermal margins are satisfactory to guarantee error-free running of the machine under certain conditions. Disadvantage is that the sensor requires sensitive and accurate electronics to obtain a reliable reading

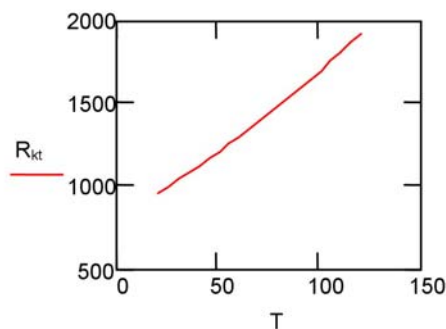

Figure 12: Temperature dependence of KTY 21-6 sensor

T (°C)	0	10	20	30	40	50	60	70	80	90	100	110	120	130
R _{KTY} (Ω)	815	886	961	1040	1123	1209	1300	1394	1492	1594	1700	1810	1923	2041

The sensor should operate under a constant current of 0-2mA. The resistance is not linear with temperature, but a voltage linear with temperature can be obtained when using a resistor network as in the schedule. The accuracy will be around $\pm 5^{\circ}\text{C}$ (with measured resistors), but can be improved to $\pm 1^{\circ}\text{C}$ if this “thermometer” is calibrated at 1 or 2 relevant temperatures (put the complete coil unit into an oven). Contact Tecnotion if more information is needed.

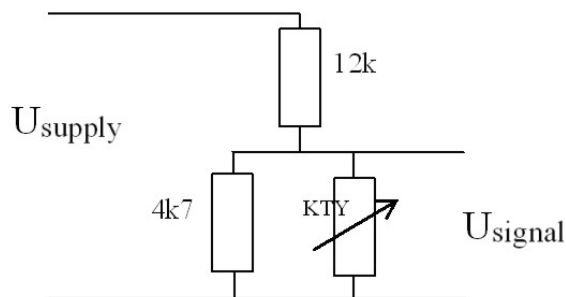

Figure 13: Scheme for obtaining a linear voltage signal from the KTY-sensor



Once more

Attention: In mid-2008 the KTY-sensor will be replaced by a newer type. For more information please contact Tecnotion.

3.5.8. Polarization test



Before testing, make sure that the electrical and mechanical protection of the linear motor system is well configured!

There is one regular way of testing the polarization. Some servo amplifiers can operate in an *in moment service* mode. By means of regulating an external resolver manually, it can be determined whether the motor's direction of running conforms the resolver's sense of

rotation. If so, the motor is well connected. If not, two phases of the power cable – phase 1 and 3 – must be changed.

Internally all ironless linear motors are equally wired and connected, so one test satisfies to find out the polarization of a motor ruler combination. If more axes are constructed in a similar way the polarization will be equal.

For more information, please contact Tecnotion.

Chapter

Ch

4. Operation

4.1. General

When you are convinced that your application's linear motor system is assembled in a proper way, both mechanically and electrically, you can do the next step. You can put your motor system into operation.

But before powering the system, please do have a final check:



- 1. Does the slide have a free run along the whole magnet track, without rubbing against any part of the track?*
- 2. Are the mechanical end stops, end switches and the dampers well dimensioned and properly configured?*
- 3. Does your system have an emergency stop within reach?*
- 4. Has the PE connection been made?*
- 5. Has the temperature cable been properly connected?*
- 6. Has the power cable been properly connected?*

4.2. Configuring

The amplifier can be powered up.

The following items should be configured as parameter settings of your specific servo amplifier:

- Presence and switch mode of end switches,
- Presence of an electromechanical brake,
- Type and interface of feedback device,
- Motor type,
- Maximum continuous current,
- Maximum peak current,
- Switching resistance of the temperature sensor,
- Safety set-up: what should be the systems reaction in case of contacting end-switches, disable, over-current, over-speed, emergency stop, etcetera,
- Magnetic alignment,
- Homing procedure,
- Analogue inputs for receiving analogue commands of controller,
- Current loop settings,
- Speed loop settings,
- Position loop settings.

Depending of the use of rotary or linear based software some items must be configured as well.

For rotary based software:

- Number of poles: 2 (makes one rotation equal to one pole pitch NN),

- Maximum speed (rpm),
- Number of increments or periods of feedback device in one rotation (divide pole pitch length by increments per pole pitch).

For linear based software:

- Pole pitch,
- Maximum speed (units!),
- Resolution or period of feedback device.

4.3. Testing

Before handing over the control of the linear motor to the closed loop feedback controllers, it is wise to perform some tests. Most important issue for testing are the end switches.



Before testing, make sure that the electrical and mechanical protection of the linear motor system is well configured!

4.3.1. End switches

Check the end switches by pushing the slide manually to the switch position. Simultaneously check whether the signal is detected by the amplifier.

4.4. Starting up

Generally spoken, build it up in small steps. Don't climb the stairs with 2 or 3 steps in one time.

Start the tuning with only the speed loop, initially with very low speeds. Then make the step to position control, but still with limited speeds.

Increase maximum speed only if everything operates properly and only when you are in the right configuration. Speed limits save the mechanics.

4.5. Optimization of control settings

Generally, current loop settings are not very critical for the motor performance and mostly there is a wide band of settings that will do. The current loop settings are only depending on amplifier and motor, not on other application parameters.

The speed loop is often the limiting factor of the servo performance, because it is sensitive for all kinds of oscillations, noise and (filter) delays. You should spend some time to get this loop proper, before optimizing the position loop. Two tips:

- Vary the filter time on the feedback speed signal. Balance noise against bandwidth reduction.
- Mostly the hardest setting possible is not the best.

The position loop can only be tuned with a correct speed loop.