



Technologies, Inc.

28310-C Ave Crocker • Valencia, CA 91355
E-mail: info@h2wtech.com
Call Toll Free: 888.702.0540
Phone: 661.702-9346 • Fax: 661.702.9348

Innovation in Linear Motion

Representative Binder



I. POSITIONING STAGES

A. AIR BEARING STAGES

B. BELT DRIVEN POSITIONING STAGES

C. DUAL RAIL LINEAR MOTOR STAGES

D. SINGLE RAIL LINEAR MOTOR STAGES

E. CROSS ROLLER STAGES

II. LINEAR MOTORS

A. LINEAR STEPPER MOTORS

B. BRUSHLESS LINEAR MOTORS

C. LINEAR BRUSH MOTORS

D. VOICE COIL LINEAR ACTUATORS

E. LINEAR INDUCTION MOTORS



III. LIMITED ANGLE TORQUE MOTORS

IV. NEW PRODUCT RELEASES

AIR BEARING POSITIONING STAGE

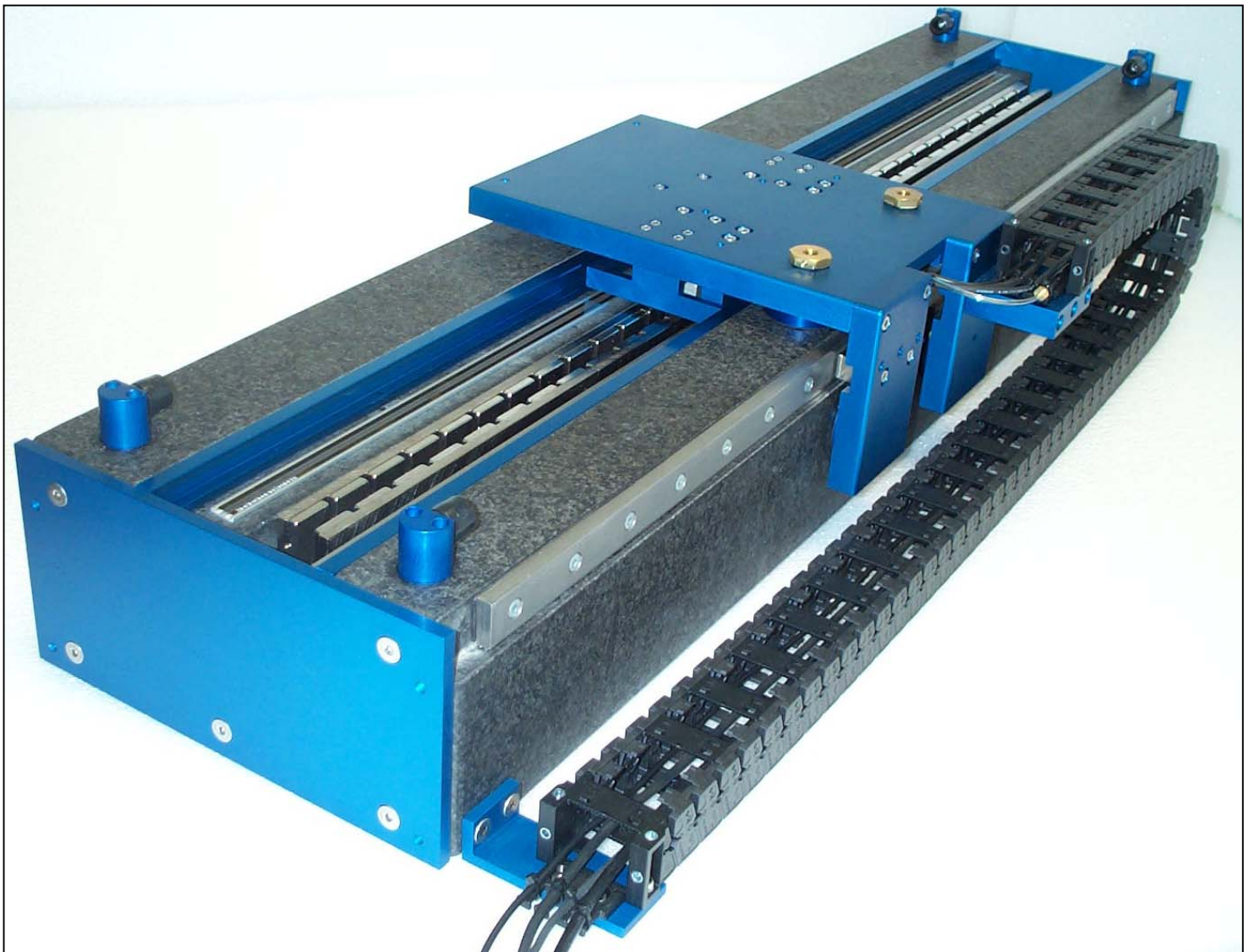

AB Positioning Stage

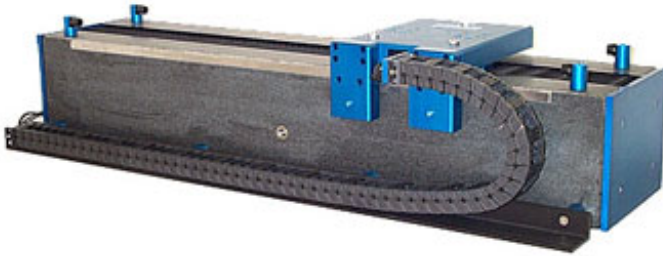

Travel	80 inches	[2 m]
Velocity	200 inches / sec	[5 m/s]
Acceleration	9 G's	9 G's
Peak Force	240 lbs	[1067 N]
Continuous Force	71 lbs	[316 N]
Resolution	.00004" or .0002"	[1 or 5 micron]

The AB Positioning Stage is a high precision, granite base, air bearing positioning stage for high end positioning applications. It is driven by an ironless core, non-cogging 3 phase brushless linear motor and guided by 5 flat magnetically preloaded air bearings floating on a granite base

The ironless core coil assembly is used as the drive mechanism for the AB stage because of its smooth, non-cogging operation. The lightweight of the coil and table assembly allows for high acceleration of light loads.

The air bearings, which are used for supporting and guiding the payload, float on a cushion of air. This ensures that there are no wearing components in the system. The air bearings are not limited to acceleration limits like their mechanical counterparts where balls and rollers can slide instead of roll at high accelerations.

The stiff cross section of the granite base of the stage ensures a flat straight stable platform for the payload to ride on and does not require any special mounting considerations.

The AB stage comes standard with bellows (folded way covers) with a 12:1 extension to compression ratio.

The power for the moving 3 phase coil assembly, encoder and limit switches is routed through shielded flat ribbon cable. Special consideration was made to separate the power and signal cables from each other to reduce the effects of noise on the system. The power cable for the coil assembly and a vacant cable for the customers payload power usage are installed on one side of the stage and the encoder signal, limit switch and an additional vacant signal cable for the customers payload signal usage is provided on the other side of the stage. Standard connectors are provided.

Advantages:

- Excellent flatness and straightness specifications
- Lowest velocity ripple
- No wearing parts
- Enclosed with bellows

Applications:

- Pick and Place
- Vision Inspection
- Parts transfer
- Clean room

The AB positioning stage incorporates the latest in linear motion technology:

- **Motors:** Non-contact 3 Phase Brushless Linear Motor, Ironless Core, commutated either sinusoidally or trapezoidally with Hall Effects. The encapsulated coil assembly moves and the multi pole permanent magnet assembly is stationary. The lightweight coil assembly allows for higher acceleration of light payloads.
- **Bearings:** Linear guidance is achieved by using magnetically preloaded, porous carbon or ceramic air bearings; 3 on the top surface and 2 on the side surface. The bearings are mounted on spherical surfaces. Clean, dry filtered air must be supplied to the moving table of the AB stage.
- **Encoders:** Non-contact glass or metal scale optical linear encoders with a reference mark for homing. Multiple reference marks are available and are spaced every 50 mm down the length of the scale. Typical encoder output is A and B square wave signals but sinusoidal output is available as an option
- **Limit Switches:** End of travel limit switches are included at both ends of the stroke. The switches can be either active high (5V to 24V) or active low. The switches can be used to shut down the amplifier or to signal the controller that an error has occurred. The limit switches are typically an integral part of the encoder, but can be mounted separately if required.
- **Cable Carriers:** Cable guidance is achieved by using flat, shielded ribbon cable. Two additional unused shielded flat ribbon cables are supplied for customer usage with the stage. The 2 power cables for the stage and customer payload are installed on one side of the stage and the 2 signal cables for encoder, limit switch and customer payload are installed separately on the of the stage.
- **Bellows:** The AB comes standard with neoprene / nylon bellows with Mylar stiffeners.

Required Electronics:

The motor requires a 3 phase brushless amplifier with power supply, which is rated with sufficient current and voltage to meet the motion requirements. The inductance of the linear motor coil should be greater than the minimum load inductance of the servo amplifier. A programmable motion controller is required to close the position loop on the system.

Environmental Considerations:

The stage is a precision device with sensitive components, it should not be mounted in an environment that is wet or excessively dirty. The optical encoder scale is open and it should be kept free of debris in order to operate properly. The stationary magnetic assembly is highly magnetic, it should not be placed in an area where loose steel particles can be drawn into the magnetic gap. The stage must not be mounted in an environment with high ambient temperatures (>50°C).

Mounting:

The stage should be mounted to flat and stiff surface. Counter bored thru holes are present in the stage to allow for the mounting of the stage to the customers system. The moving table assembly has threaded holes on the top surface for attaching the payload. The stage may be mounted in any orientation. When mounting the stage with the table moving vertical, it should be noted that the stage will be required to generate additional force due to gravity and that the stage will slide down to the bottom hard stop when power fails.

Maintenance:

The ball bearing guides in the stage should be periodically lubricated with the manufacturers recommended grease.

Ordering Info:

Stages can be ordered for any stroke up to 80 inches and any continuous force up to 24 lbs. The stages are built as the orders are placed, they are not stocked, as each customer requirement is different.

Model # ABS – AAA – BB – CCC - D

where: AAA is the stroke in inches (30 inch stroke is -030)
 BB is the width of the stage (7 inch width is -07)
 CCC is the continuous force (24 lbs is -024)
 D is for special options

(i.e. ABS-030-07-024-0 is a 7" wide AB stage with a 30" stroke, 24 lbs of continuous force and no special options)

Specifications:

Flatness	±.0001" /ft	±8 micron / meter
Straightness	±.0001" /ft	±8 micron / meter
Accuracy*	±.0002" /ft	±16 micron / meter
Repeatability*	±.0001"	±2.5 micron
Load Capacity	22 lbs	10 Kg

(*Encoder dependent)

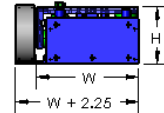
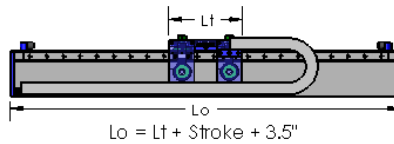
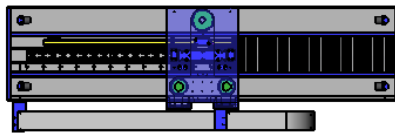
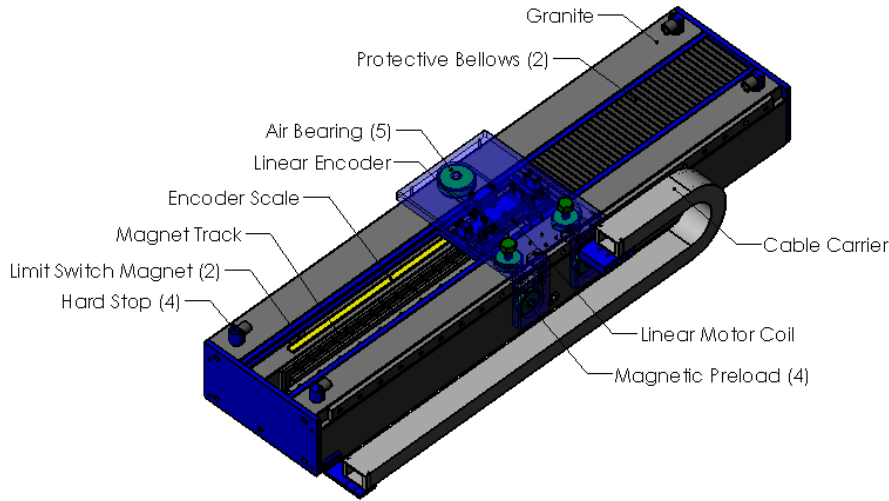

Model #	Stage Width (W)	Stage Height (H)	Table Length (Lt)	Continuous Force	Peak Force
ABS-XXX-10-025A	9.5" [241 mm]	5.60" [142 mm]	6.35 [161 mm]	25 lbs [111 N]	80 lbs [356 N]
ABS-XXX-10-036A	9.5" [241 mm]	5.60" [142 mm]	8.75 [222 mm]	36 lbs [160 N]	120 lbs [533 N]
ABS-XXX-10-047A	9.5" [241 mm]	5.60" [142 mm]	11.15 [283 mm]	47 lbs [209 N]	160 lbs [711 N]
ABS-XXX-10-059A	9.5" [241 mm]	5.60" [142 mm]	13.55 [344 mm]	59 lbs [262 N]	200 lbs [889 N]
ABS-XXX-10-071A	9.5" [241 mm]	5.60" [142 mm]	15.95 [405 mm]	71 lbs [316 N]	240 lbs [1067 N]



Flat air bearings can be readily used to create custom air stages. The gimbed mount allows for great flexibility in tolerance and the threaded ball studs make alignment easy. These bearings are appropriate for highly loaded applications and are the easiest type of air bearings to integrate into prototype designs as they can be readily replaced or changed. Standard and custom bearings are available including replacement bearings for many CMM's.

Typical Applications :

Coordinate measuring machines, specialty gauging, vision machines, high speed applications, diamond turning machines, dry machining of metals.

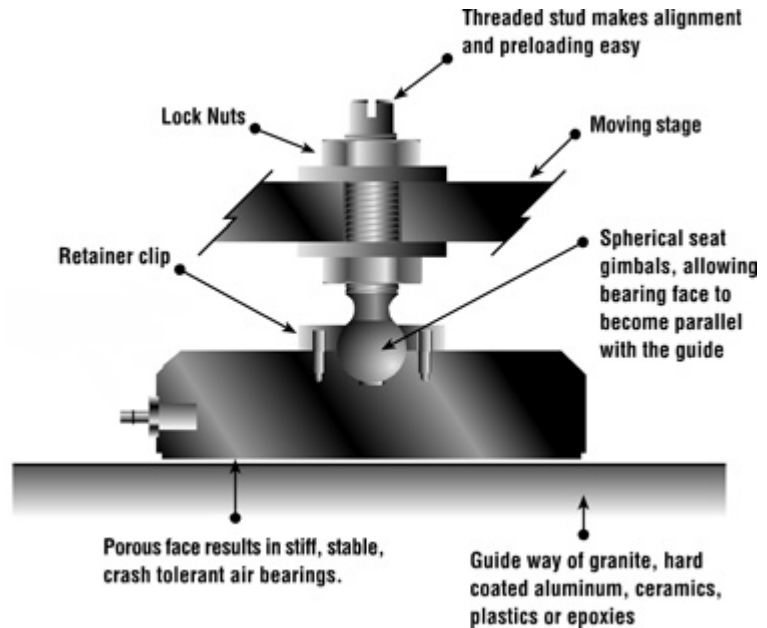

Porous Media Options; Carbon and Silicon Carbide (SiC)

Carbon Porous Media

We recommend selecting the Carbon media for most applications - this media is typically softer than the guide surface so if a touchdown or "crash" occurs, there will be no damage to the guideway. The Carbon media is designed to act as a plain bearing and can operate for brief periods without air with no measurable effect on the bearing performance. This offers a significant advantage in comparison with an "orifice" type air bearing. If an orifice type air bearing comes in contact with the guideway, the bearing and guide surfaces will be scratched. After repeated contact, these scratches will create valleys that change the net air gap (or fly height) which will affect the air bearing performance (reduction of air film stiffness). As this damage continues, spalling will occur and the bearings will fail. The New Way Carbon media offers a much more robust solution and is not susceptible to these types of failures.

Silicon Carbide (SiC) Porous Media

The SiC media is very hard and can scratch a guide surface if it comes in contact. It is more expensive (approximately twice the cost of a bearing with Carbon media) and therefore should only be used in the specialized applications that require it. As mentioned above, the Carbon media is softer than the typical guide surface, so there is a risk of particulation in the event of a touchdown. The amount of particulation is often insignificant and will only occur in the event of contact during a "crash". Of course the potential amount of particulation will depend on the velocity, area of contact, time period of contact, etc. The SiC media will not particulate if it comes in contact, but can damage the guide surface.

The choice between selecting Carbon vs SiC media should be looked at from an economic point of view; If the motion system is unstable, and there is a risk of a crash, what will cause the most damage? If Carbon media is used, and a particulation event occurs, is this more costly than permanent damage to a guideway in the case of SiC media touchdown that may require a machine shutdown and repair? In well designed systems, a crash does not occur so in most cases this should not be a concern.

AB STAGE

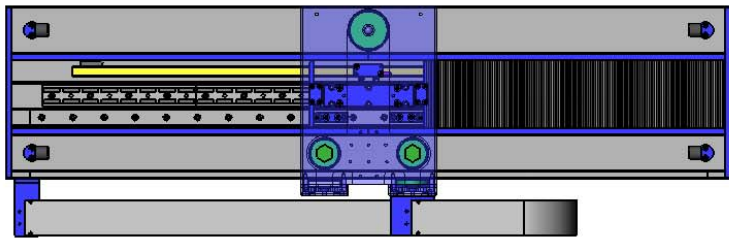
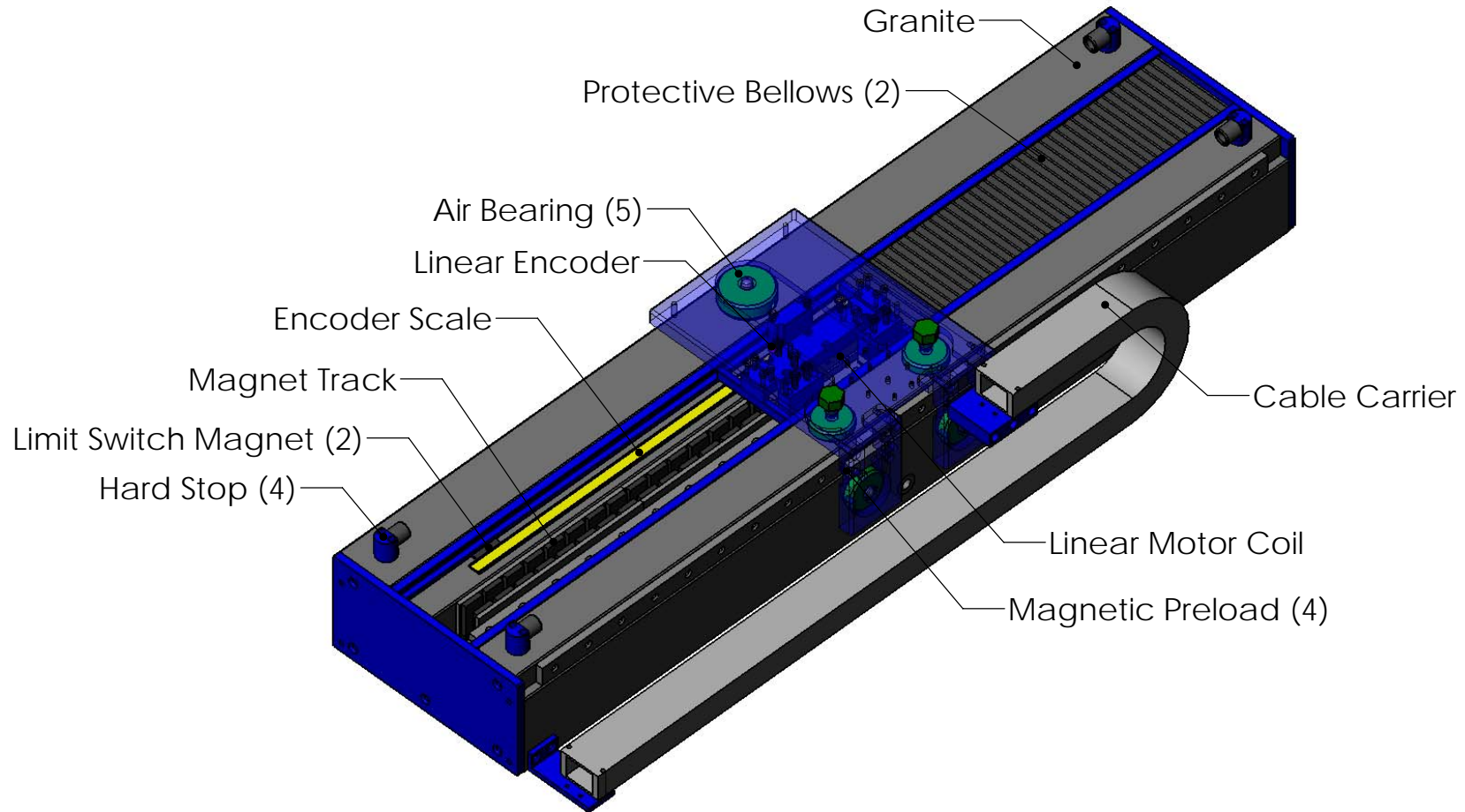

TOP

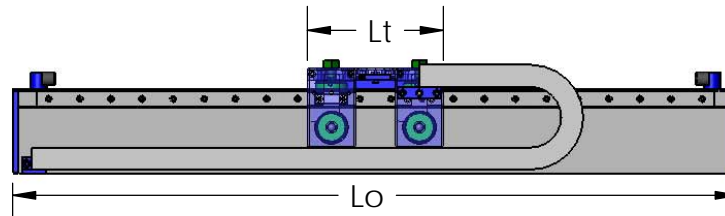

$$L_o = L_t + \text{Stroke} + 3.5"$$

SIDE

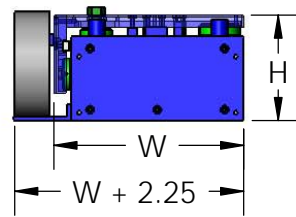

FRONT

MULTI AXIS AIR BEARING POSITIONING STAGES

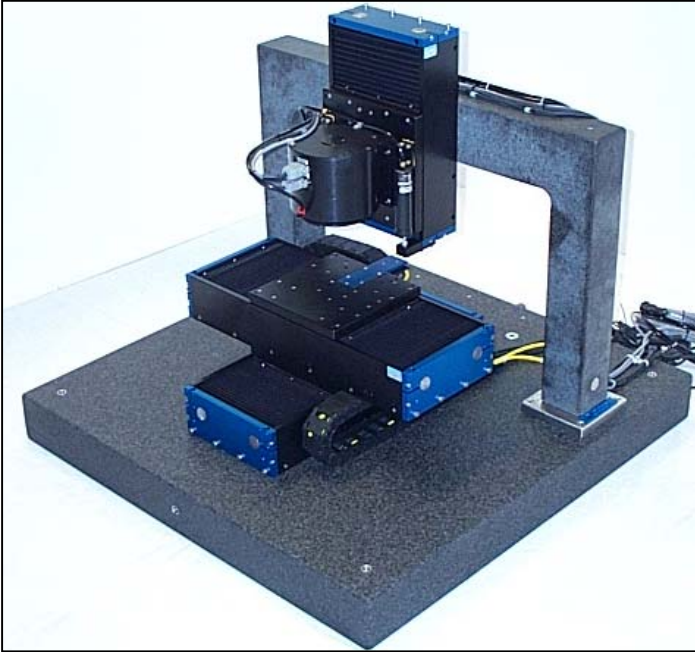

XYZ-THETA AIR BEARING STAGE

X-AXIS = 10 in, 20 lbs cont. 80 lbs peak, 0.1 μ m encoder resolution
Y-AXIS = 10 in, 20 lbs cont. 80 lbs peak, 0.1 μ m encoder resolution
Z-AXIS = 3 in, 20 lbs cont. 92 lbs peak, 0.1 μ m encoder resolution
THETA AXIS = 300°, 3.57 arcsec encoder resolution

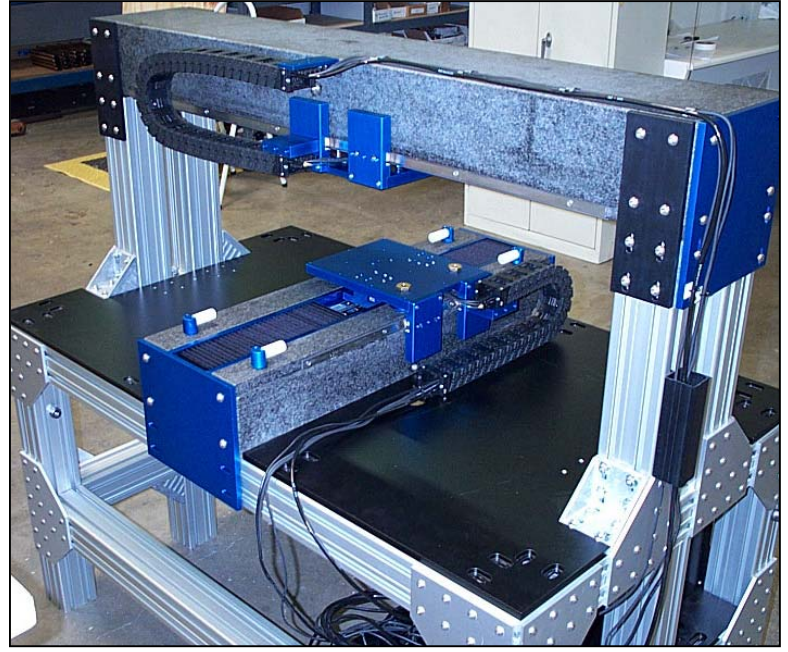

XY AIR BEARING STAGE (INVERTED Y-AXIS)

X-AXIS = 20 in, 20 lbs cont. 80 lbs peak, 1 μ m encoder resolution
Y-AXIS = 42 in, 30 lbs cont. 120 lbs peak, 1 μ m encoder resolution

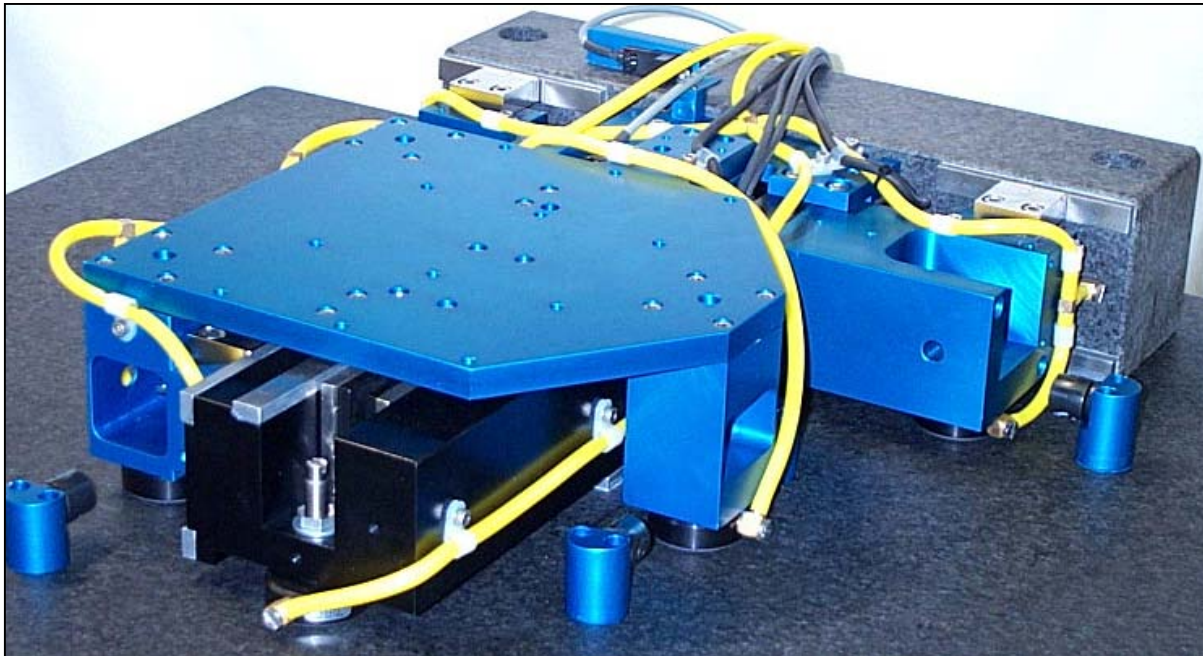

XY SINGLE PLANE AIR BEARING STAGE

X-AXIS = 4 in, 20 lbs cont. 80 lbs peak, 50 nano meter encoder resolution
Y-AXIS = 4 in, 20 lbs cont. 80 lbs peak, 50 nano meter encoder resolution
* X and Y Axis float on the same air bearing surface.

BELT DRIVE POSITIONING STAGE

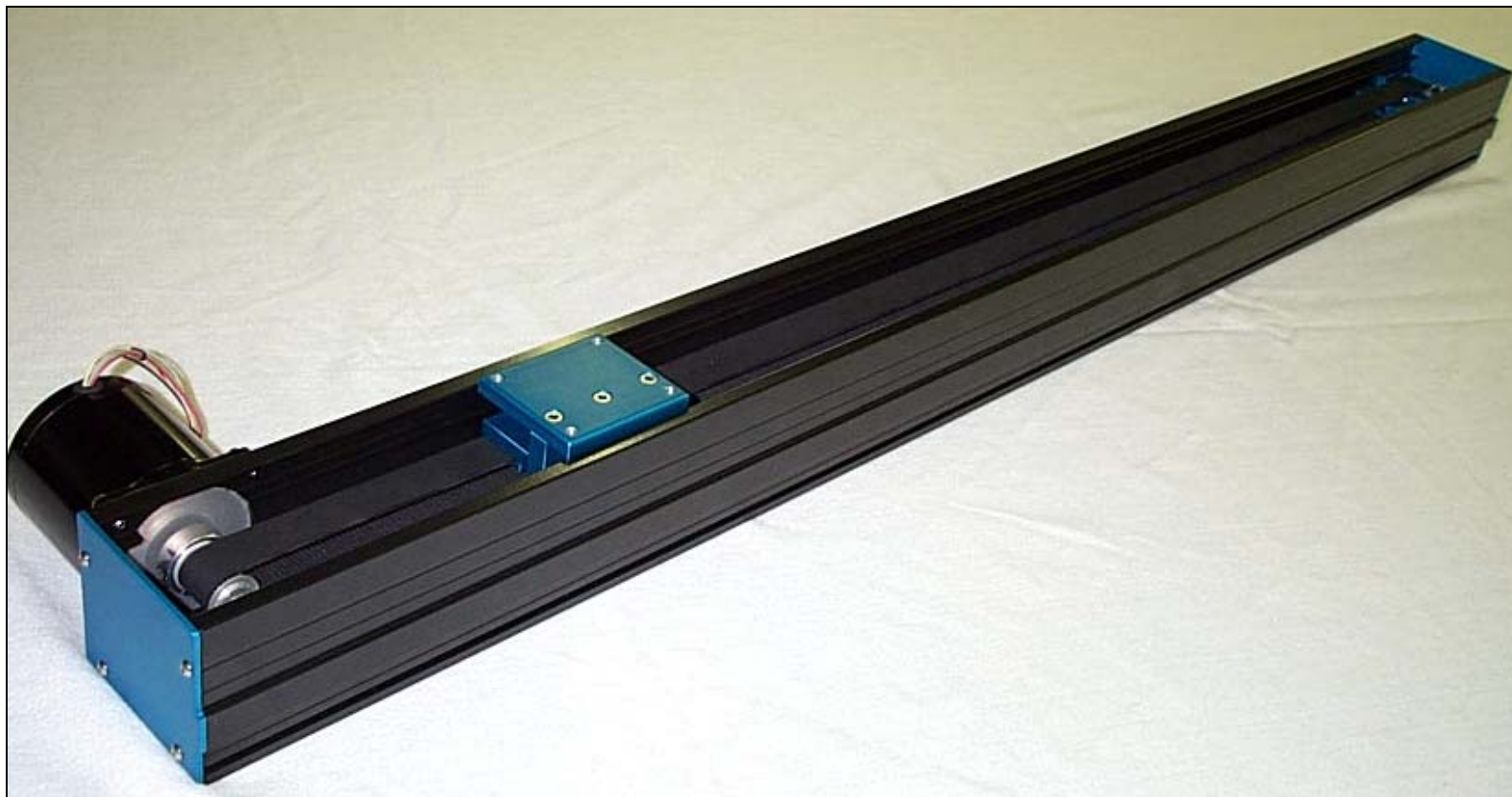

Belt Drive (BL) Positioning Stage

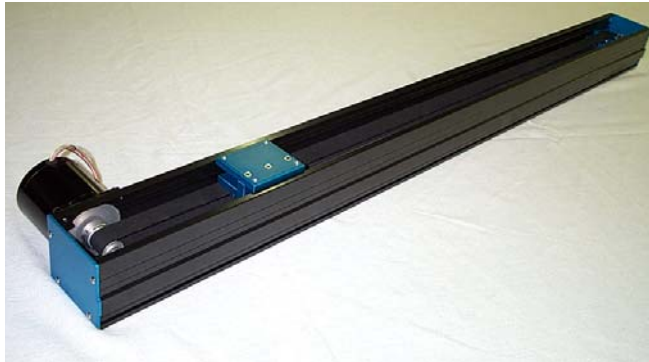

Travel	134 in	[3.65 m]
Velocity	200 in/sec	[5 m/s]
Acceleration	2 G's	2 G's
Peak Force	150 lbs	[667 N]
Continuous Force	50 lbs	[222 N]
Accuracy	+/-0.006in/ft	[+/-500 μ m/m]
Repeatability	+/-0.004 in	[+/-100 μ m]
Flatness	+/-0.002 in/ft	[+/-165 μ m/m]
Straightness	0.013in/ft	[+/-108 μ m/m]

The BL Series belt drive stage is a low cost, durable and surprisingly quiet positioning stage that is well suited for both open and closed loop operation. The stage is capable of very slow speeds (< 0.001 inches per second) to speeds greater than 100 inches per second. Stages are offered with travel lengths up to 134 inches (3400 mm). The BL stage offers a pulley system designed for long service life and dependable operation. An optional external cable carrier is offered for easy integration of cables and hoses. There are provisions for a linear encoder, which allow for dual loop operation in applications requiring precise positioning. The carriage is supplied with tapped holes for easy mounting of your payload.

Stages can operate either horizontally or vertically and can be supplied in compound configurations for multi-axis applications.

The BL stage is offered with a bellows option (folded way covers) with a 12:1 extension to compression ratio. The bellows help to protect the belt and pulley mechanisms from contamination in dirty environments.

Advantages:

- Quiet running, high speed
- Low cost
- Long life, low maintenance
- Linear encoder option
- Cable carrier option
- Bellows option
- Two bearing options
- Motor mounts directly to the stage, no motor mounts required

Applications:

- Pick and Place
- Parts Transfer
- Water Jet Cutting Machines
- Laser Cutting/Etching Machines
- Hi Speed Sewing Machines

The BL positioning stage incorporates the latest in linear motion technology:

- **Motors:** Depending on the system requirements, stepper, DC brush and brushless AC motors are available.
- **Bearings:** The table is supported by a standard guide wheel type linear bearing. A sealed recirculation ball linear bearing option is available for applications requiring precise motion of heavier payloads.
- **Encoders:** The stage can be supplied with an optional magnetic linear encoder with quadrature output.
- **Limit Switches:** Optional end of travel limit switches are available. The switches can be used to shut down the amplifier or to signal the controller that an error has occurred.
- **Cable Carriers:** For management of hoses and cables, a cable carrier option is offered.
- **Bellows:** Neoprene / nylon bellows with Mylar stiffeners are offered as an option and provide protection in harsh environments.
- **Hard Stops:** Hard stops are incorporated into the ends of the stage to prevent over travel damage in the event of system runaway.

Required Electronics:

Depending on the type of motor selected, a stepper indexer/driver can be utilized for open loop step motor operation or a servo amplifier and programmable motion controller can be utilized for closed loop servo motor operation.

Environmental Considerations:

The stage is offered with bellows, however care should be taken to protect the stage from contamination and moisture. The stage is designed for ambient temperatures to 45 °C.

Mounting:

The stage should be mounted to a flat and rigid surface. Mounting slots are provided on the sides of the stage to allow for mounting to the customer's platform. The moving table assembly has threaded holes on the top surface for attaching the payload. The stage may be mounted in any orientation. When mounting the stage with the table moving in a vertical direction, it should be noted that the stage will be required to generate additional force due to gravity and that the stage will slide down to the bottom hard stop when power fails. A motor brake is available.

Options:

- Bearings
 - Guide wheel linear rail
 - Recirculation ball linear rail
- Motors
 - Stepper
 - Brushless AC
 - Brush DC
- Magnetic linear encoder
- Gear box
- Cable carrier
- Custom tapped holes for mounting of stage to customer's platform
- Custom tapped holes in carriage for mounting of customer's payload

Maintenance:

The ball bearing guides in the stage should be periodically lubricated with the manufacturers recommended grease. The stage is supplied with an integral spring-loaded belt tensioning system that may require periodic adjustment. Tensioning is made easy by simply loosening and tightening two adjustment screws on the outside of the stage body.

Ordering Info:

Stages can be ordered with strokes up to 134 inches and with continuous forces up to 50 lbs. The stages are built as the orders are placed, they are not stocked, as each customer requirement is different.

Model #

BLS-AAA-CCC-DD-E-F where: AAA is the stroke in inches (52 inch stroke is -052)
 CCC is the continuous force (20 lbs is -020)
 DD is for encoder option
 E is for bellows option
 F is for motor type
 1 – Stepper
 2 – Brushless AC
 3 – Brush DC

i.e. BLS-048-020-ME-B-1 is a Belt Drive Stage with a 48" stroke, 20 lbs of continuous force, magnetic linear encoder, bellows and a stepper motor.

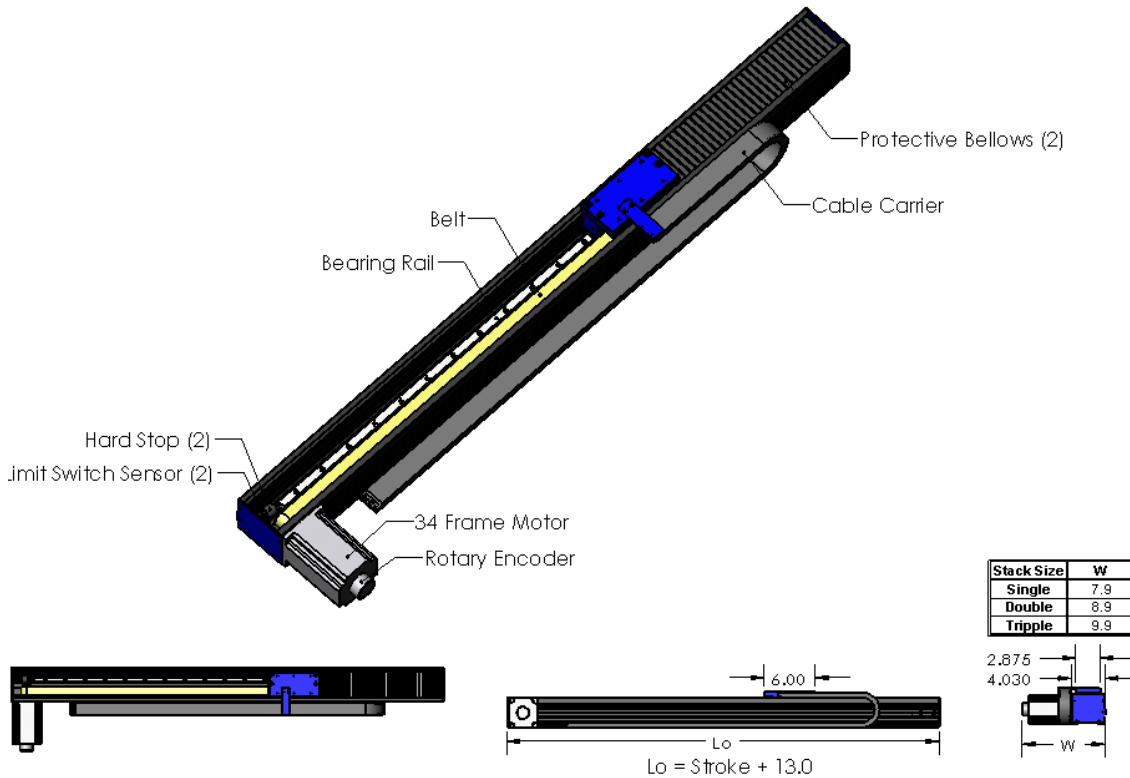

Stack Size	W
Single	7.9
Double	8.9
Tripple	9.9

Stage Width (W)	Stage Height (H)	Continuous Force Range	Peak Force range	Max Payload
4.030" [101.6 mm]	3.580" [98.5 mm]	20-50 lbs [89 N – 222N]	60-150 lbs [267 N – 667 N]	200 lbs [90.5 Kg]

BL STAGE

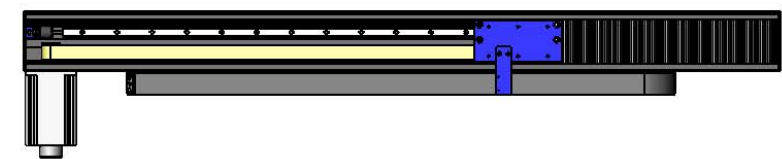
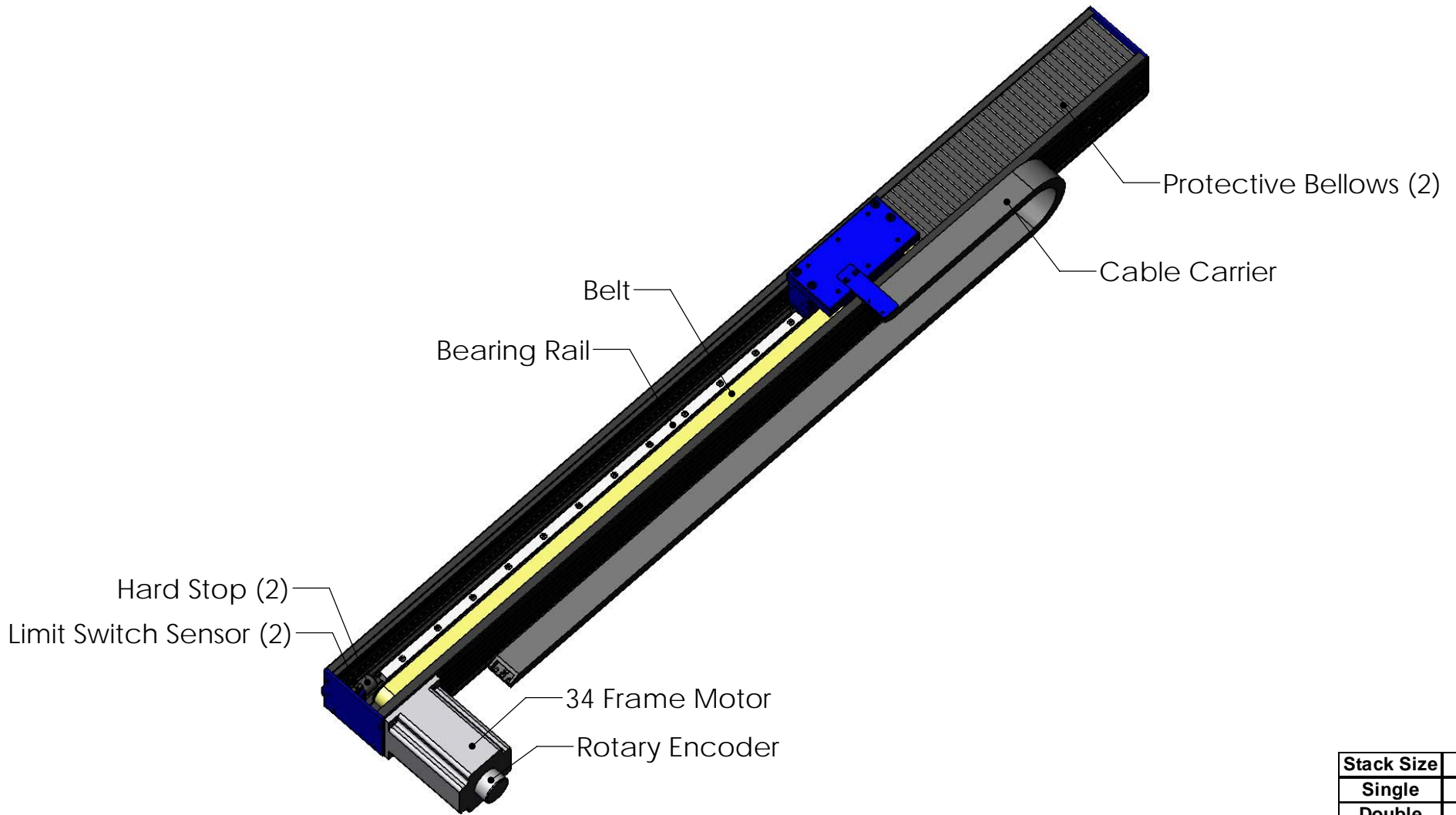

TOP

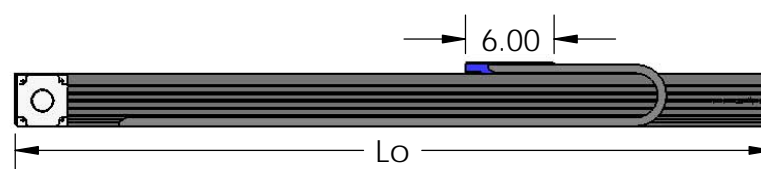

SIDE

Stack Size	W
Single	7.9
Double	8.9
Tripple	9.9

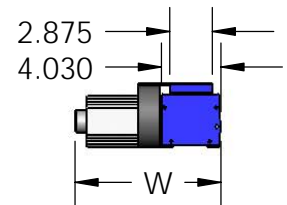

FRONT

DUAL RAIL POSITIONING STAGE

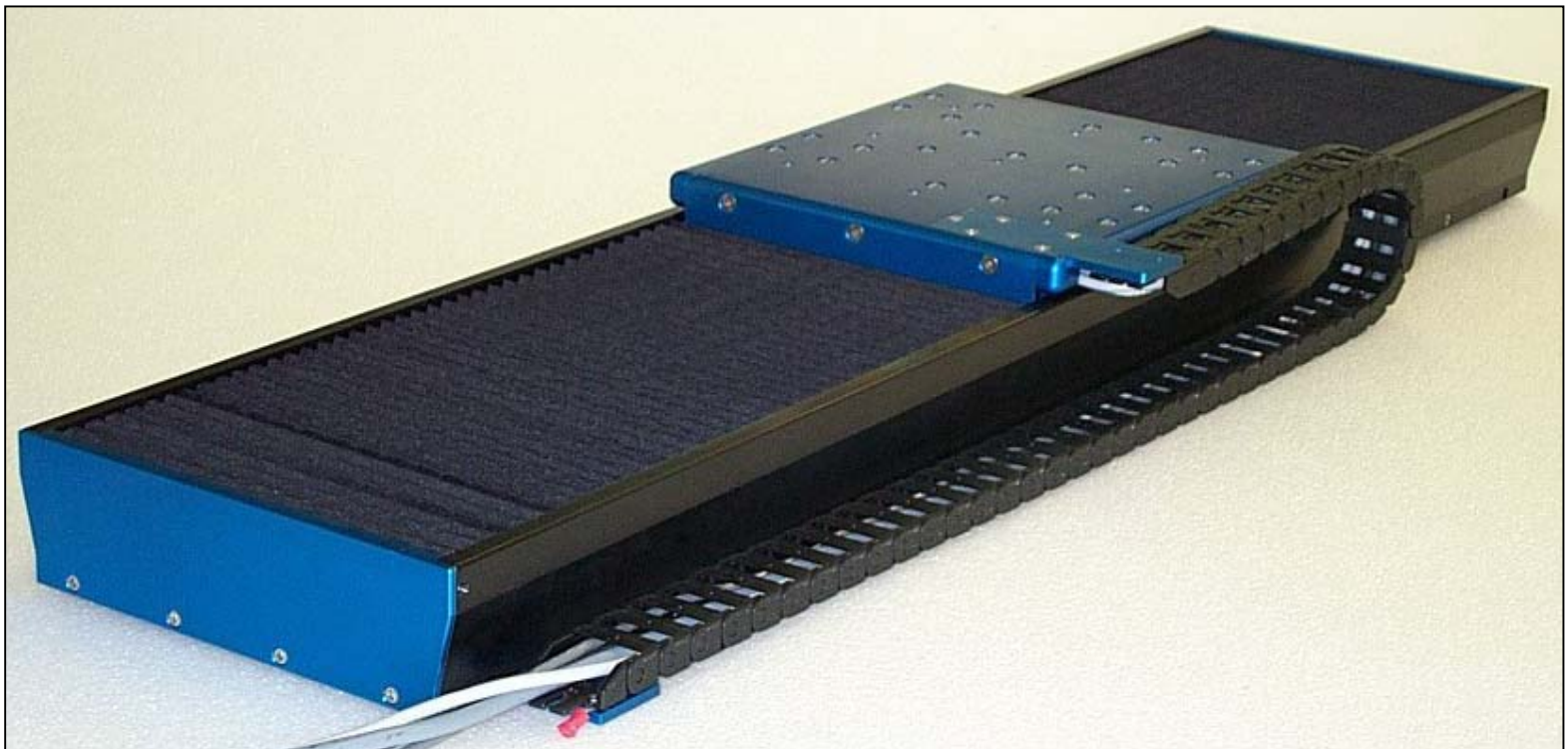

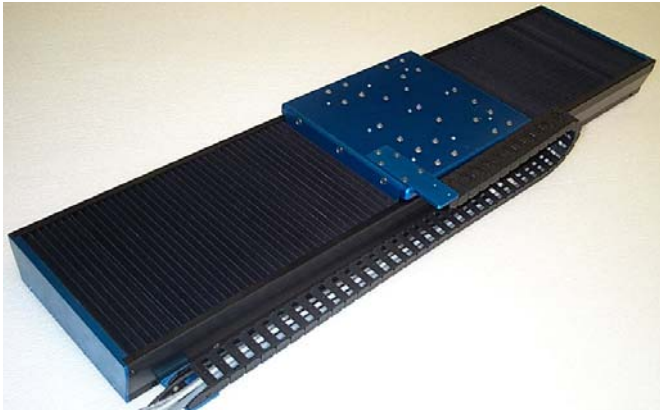

DR Positioning Stage

Travel	160 inches	[4 m]
Velocity	200 inches / sec	[5 m/s]
Acceleration	9 G's	9 G's
Peak Force	1335 lbs	[5933 N]
Continuous Force	445 lbs	[1978 N]
Resolution	.00004" or .0002"	[1 or 5 micron]

The DR stage is a low profile, wider footprint, enclosed positioning stage. It is used in closed loop positioning applications that require high speed and high accelerations of heavier loads.

The iron core coil assembly is magnetically attracted to the stationary magnet assembly, which provides a preload for the bearing system. The dual parallel linear bearing rails with 4 linear recirculating ball bushing guides provide a much higher load carrying capacity. The wide low profile of the stage ensures a stable platform for the payload or as the bottom axis (X axis) of a stacked multi-axis system

The larger size of the stage allows for the mounting of a larger, higher force linear motor.

The DR stage comes standard with bellows (folded way covers) with a 12:1 extension to compression ratio.

The cable carrier is oversized to allow for passage of customer payload cables and hoses. The back of the cable carrier can be easily removed and reattached to route through additional cables.

Advantages:

- Wide footprint, very stable platform
- Highest output force stage
- Available in 4 different widths
- Enclosed with bellows
- High Speed

Applications:

- Pick and Place
- Vision Inspection
- Parts transfer
- Clean room

The DR positioning stage incorporates the latest in linear motion technology:

- **Motors:** Non-contact 3 phase brushless , low cogging, iron core linear motor, commutated either sinusoidally or trapezoidally with Hall Effects. The encapsulated laminated coil assembly moves and the multi-pole single sided permanent magnet assembly is stationary. There is a large magnetic attractive force which provides a preload for the bearing system.
- **Bearings:** Linear guidance is achieved by using a 2 parallel linear rail with 4 linear recirculating ball bearing guides. The bearing guides are sealed with wipers to contain the lubrication and to keep out debris. Periodic lubrication of the guides is recommended.
- **Encoders:** Non-contact glass or metal scale optical linear encoders with a reference mark for homing. Multiple reference marks are available and are spaced every 50 mm down the length of the scale. Typical encoder output is A and B square wave signals but sinusoidal output is available as an option
- **Limit Switches:** End of travel limit switches are included at both ends of the stroke. The switches can be either active high (5V to 24V) or active low. The switches can be used to shut down the amplifier or to signal the controller that an error has occurred. The limit switches are typically an integral part of the encoder, but can be mounted separately if required.
- **Cable Carriers:** Cable guidance is achieved by using a cable carrier. Cable carriers are oversized to allow for routing of customers hoses and cables
- **Bellows:** The DR comes standard with neoprene / nylon bellows with Mylar stiffeners.
- **Hard Stops:** Hard stops are incorporated into the ends of the stage to prevent over travel damage in the event of servo system failure.

Required Electronics:

The motor requires a 3 phase brushless amplifier with power supply, that is rated with sufficient current and voltage to meet the motion requirements. The inductance of the linear motor coil should be greater than the minimum load inductance of the servo amplifier.

A programmable motion controller is required to close the position loop on the system.

Environmental Considerations:

The stage is a precision device with sensitive components, it should not be mounted in an environment that is wet or excessively dirty. The optical encoder scale is open and it should be kept free of debris in order to operate properly. The stationary magnetic assembly is highly magnetic, it should not be placed in an area where loose steel particles can be drawn towards the open magnetic surfaces.

The stage must not be mounted in an environment with high ambient temperatures.

Mounting:

The stage should be mounted to flat and stiff surface. Counter bored thru holes are present in the stage to allow for the mounting of the stage to the customers system. The moving table assembly has threaded holes on the top surface for attaching the payload. The stage may be mounted in any orientation. When mounting the stage with the table moving vertical, it should be noted that the stage will be required to generate additional force due to gravity and that the stage will slide down to the bottom hard stop when power fails.

Maintenance:

The ball bearing guides in the stage should be periodically lubricated with the manufacturers recommended grease. The open glass encoder scale should be wiped with a glass cleaner occasionally to ensure trouble free operation.

Ordering Info:

Stages can be ordered for any stroke up to 160 inches and any continuous force up to 479 lbs. The stages are built as the orders are placed, they are not stocked, as each customer requirement is different.

Model # DRS – AAA – BB – CCC - D

where: AAA is the stroke in inches (52 inch stroke is -052)

BB is the width of the stage (9 inch width is -09)

CCC is the continuous force (60 lbs is -060)

D is for special options

(i.e. DRS-048-09-080-0 is a 9" wide SR stage with a 48" stroke, 80 lbs of continuous force and no special options)

Specifications:

Flatness	±.0008" /ft	±66 micron / meter
Straightness	±.0009" /ft	±74 micron / meter
Accuracy*	±.0007" /ft	±57 micron / meter
Repeatability*	±.0003"	±7.5 micron
Load Capacity	442 lbs	200 Kg

(*Encoder dependent)

Model #	Stage Width (W)	Stage Height (H)	Table Length (Lt)	Continuous Force	Peak Force
DRS-XXX-09-045A	9.10" [231 mm]	3.50" [89 mm]	10.00 [254 mm]	45 lbs [200 N]	135 lbs [600 N]
DRS-XXX-09-085A	9.10" [231 mm]	3.50" [89 mm]	17.00 [432 mm]	85 lbs [378 N]	275 lbs [1222 N]
DRS-XXX-09-125A	9.10" [231 mm]	3.50" [89 mm]	24.00 [610 mm]	125 lbs [555 N]	415 lbs [1844 N]
DRS-XXX-11-080A	11.10" [282 mm]	4.0" [102 mm]	10.00 [254 mm]	80 lbs [355 N]	240 lbs [1065 N]
DRS-XXX-11-160A	11.10" [282 mm]	4.0" [102 mm]	17.00 [432 mm]	160 lbs [710 N]	480 lbs [2133 N]
DRS-XXX-11-235A	11.10" [282 mm]	4.0" [102 mm]	24.00 [610 mm]	235 lbs [1044 N]	705 lbs [3133 N]
DRS-XXX-14-120A	13.6" [345 mm]	4.5" [114 mm]	10.00 [254 mm]	120 lbs [533 N]	360 lbs [1600 N]
DRS-XXX-14-230A	13.6" [345 mm]	4.5" [114 mm]	17.00 [432 mm]	230 lbs [1022 N]	690 lbs [3067 N]
DRS-XXX-14-340A	13.6" [345 mm]	4.5" [114 mm]	24.00 [610 mm]	340 lbs [1511 N]	1020 lbs [4533 N]
DRS-XXX-16-160A	15.6" [396 mm]	5.0" [127 mm]	10.00 [254 mm]	160 lbs [710 N]	480 lbs [2133 N]
DRS-XXX-16-300A	15.6" [396 mm]	5.0" [127 mm]	17.00 [432 mm]	300 lbs [1333 N]	900 lbs [4000 N]
DRS-XXX-16-445A	15.6" [396 mm]	5.0" [127 mm]	24.00 [610 mm]	445 lbs [1978 N]	1335 lbs [5933 N]

* Water Cooling option on linear motor coil assembly doubles continuous force rating (peak force rating stays the same)

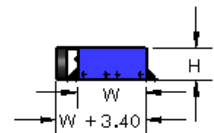
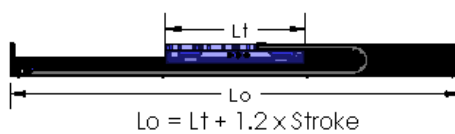
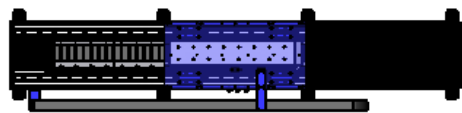
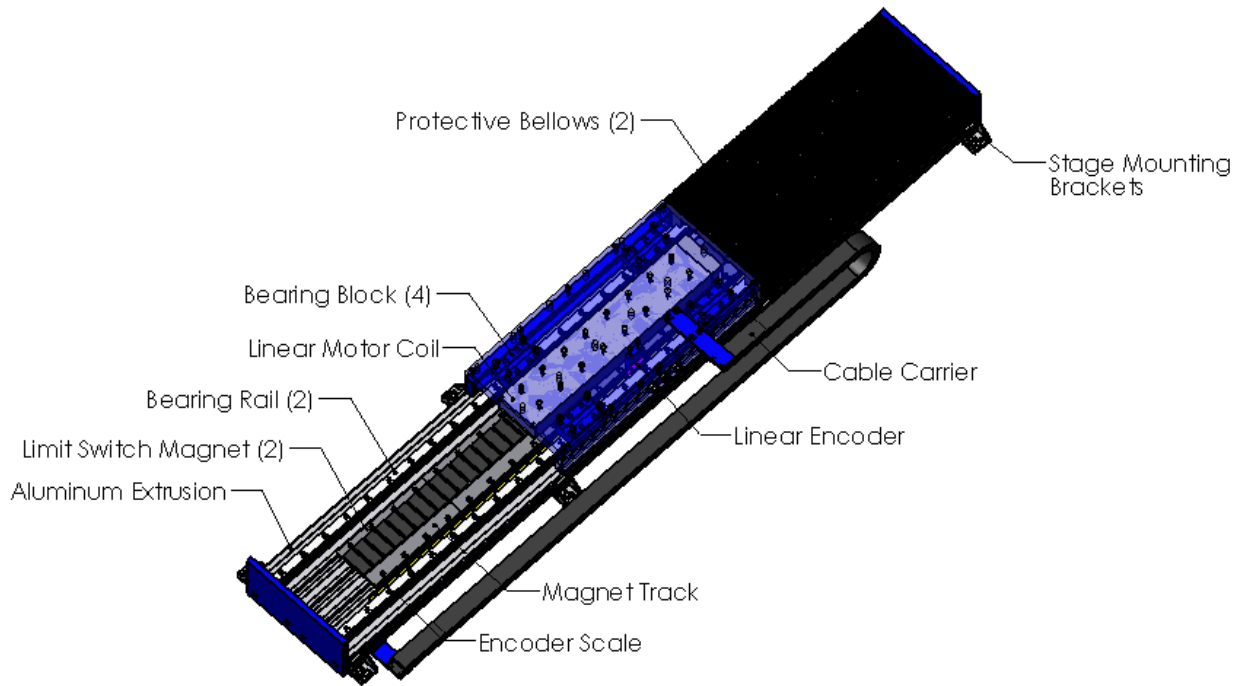
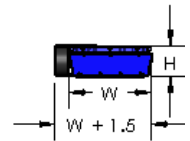
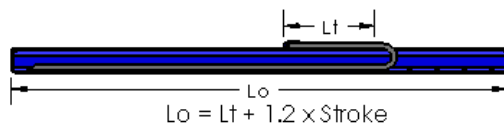
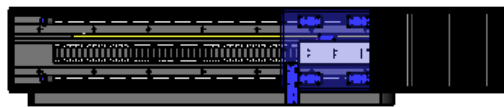
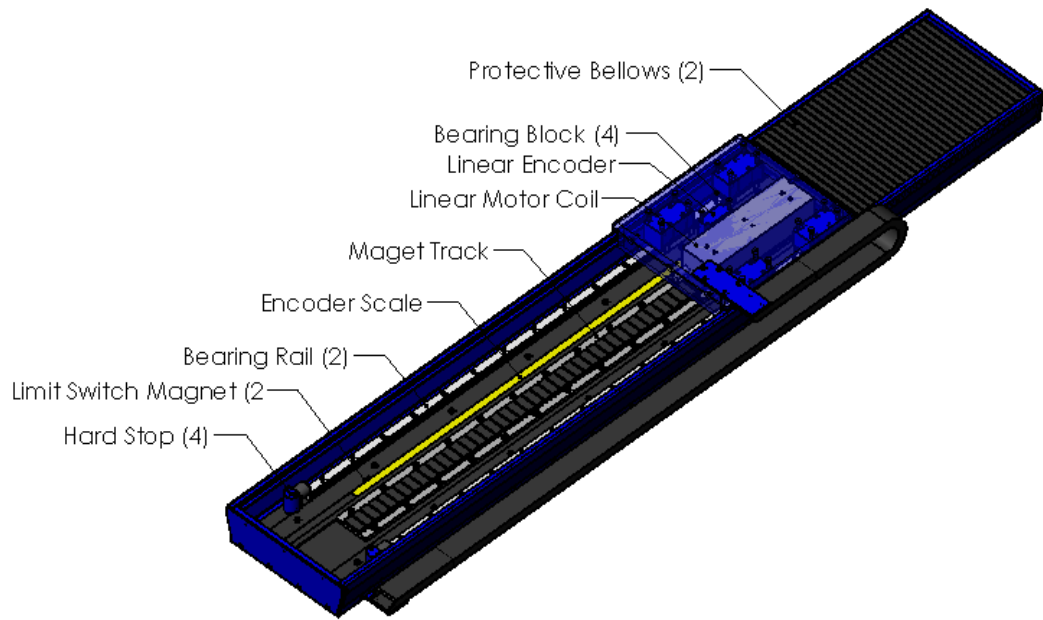

DR STAGE

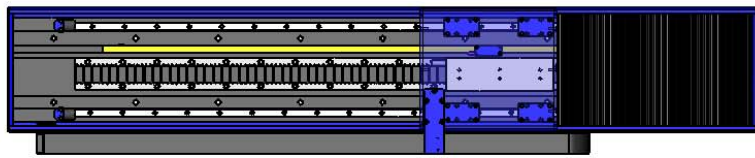
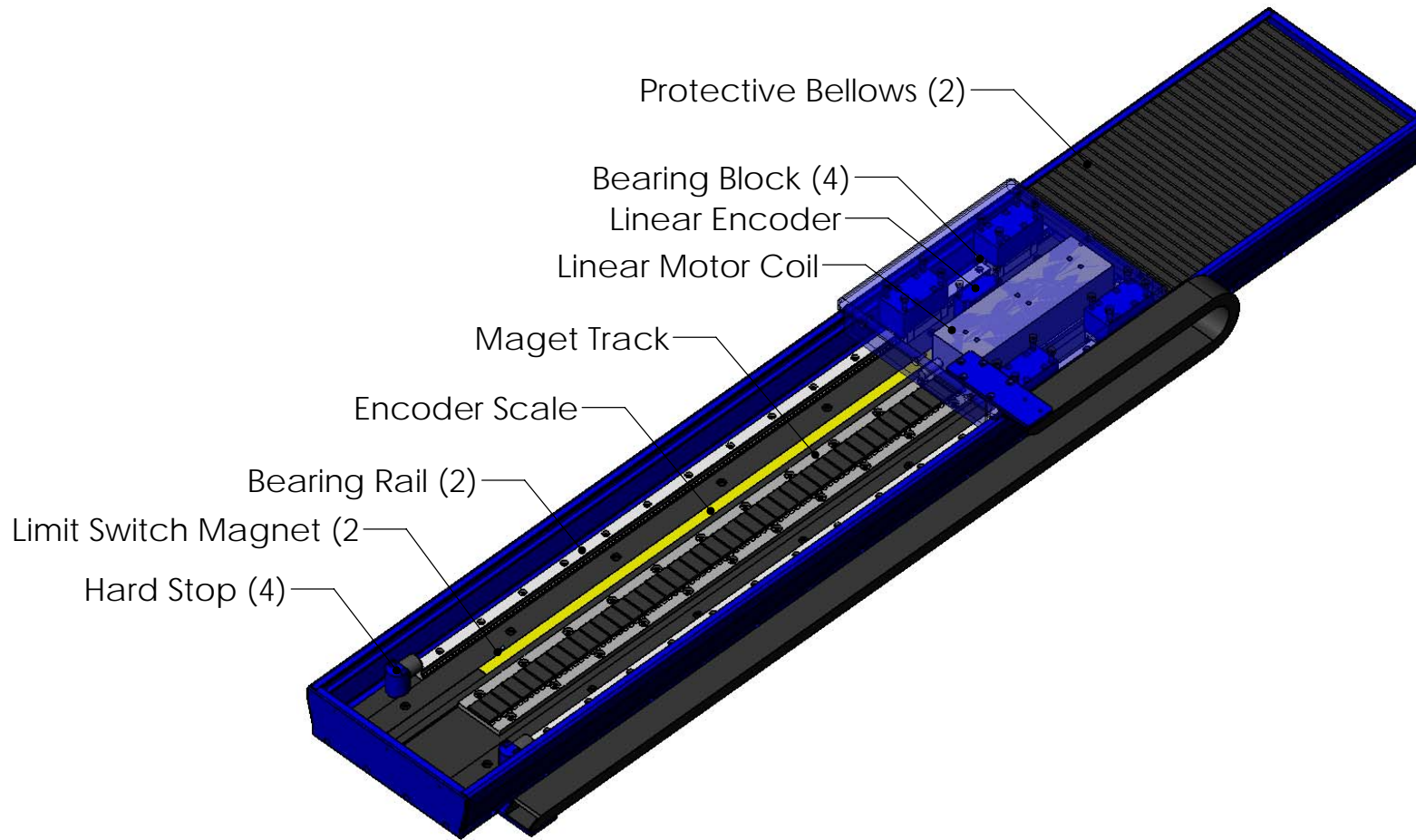

TOP

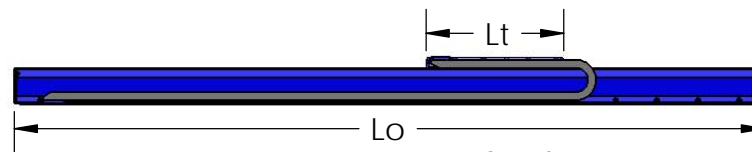

SIDE

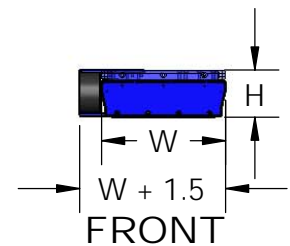

FRONT

EXTRUSION DR STAGE

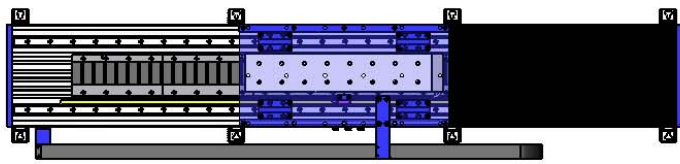
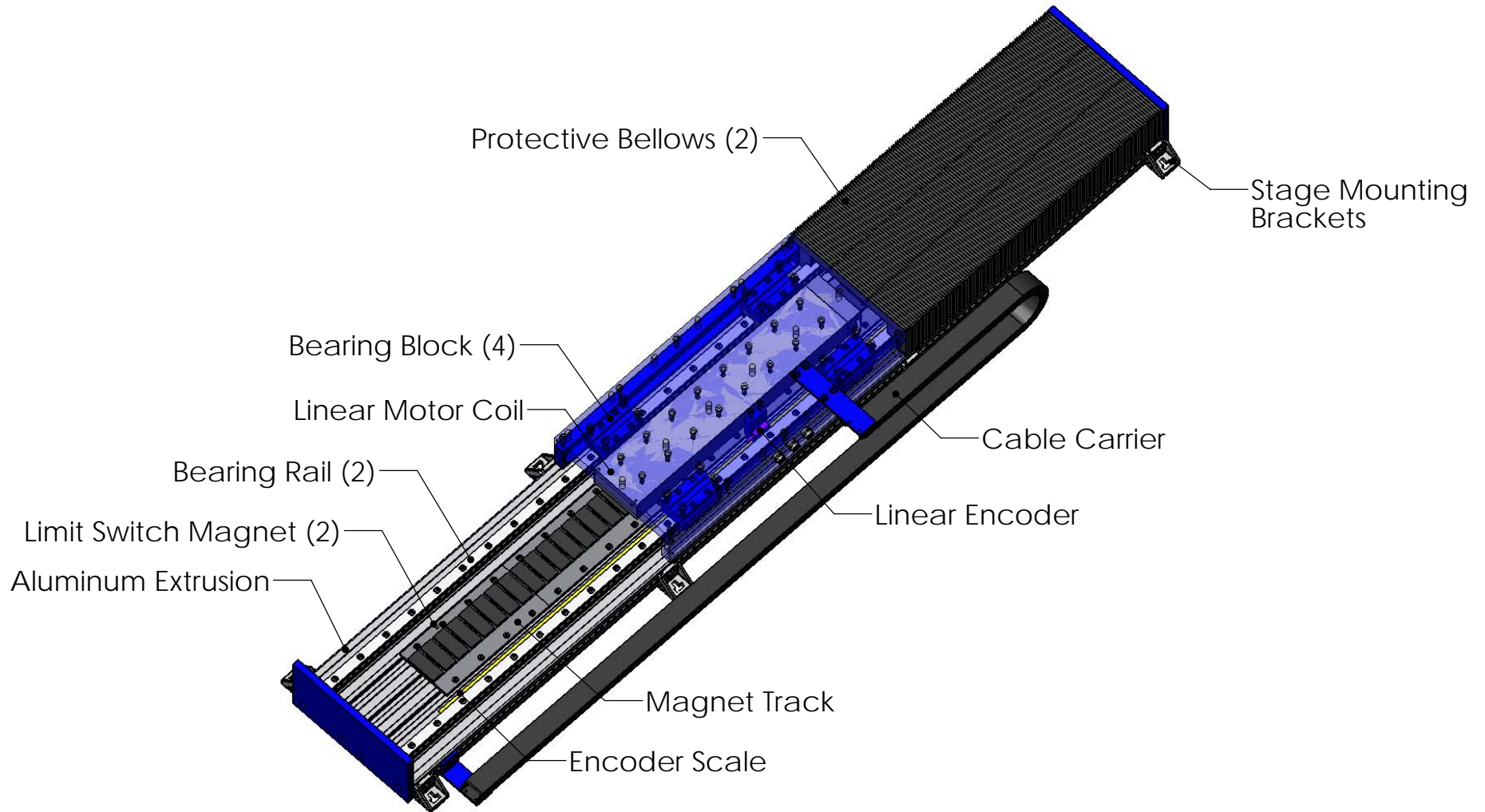

TOP

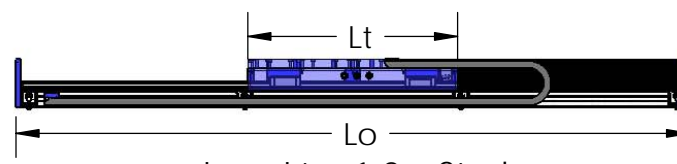

SIDE

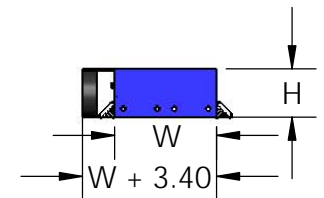

FRONT

DUAL RAIL POSITIONING STAGES

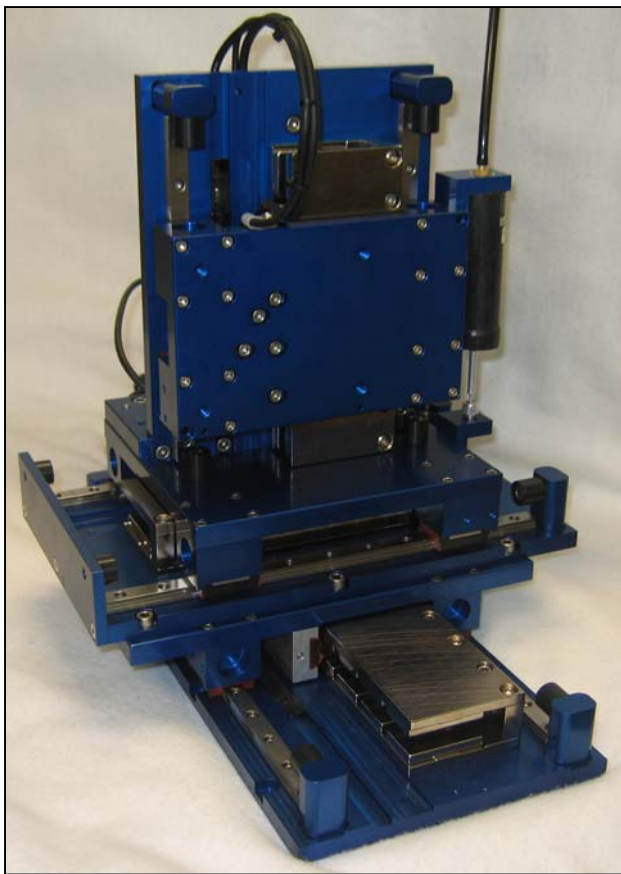

XYZ Gantry (High Resolution)

X-AXIS = 12" stroke, 20 lbs cont., 50 lbs peak

Y-AXIS = 3" stroke, 20 lbs cont., 80 lbs peak

Z-AXIS = 3" stroke, 10 lbs cont., 40 lbs peak

*Z-Axis counterbalance

*All axis have 0.1 μm resolution encoders

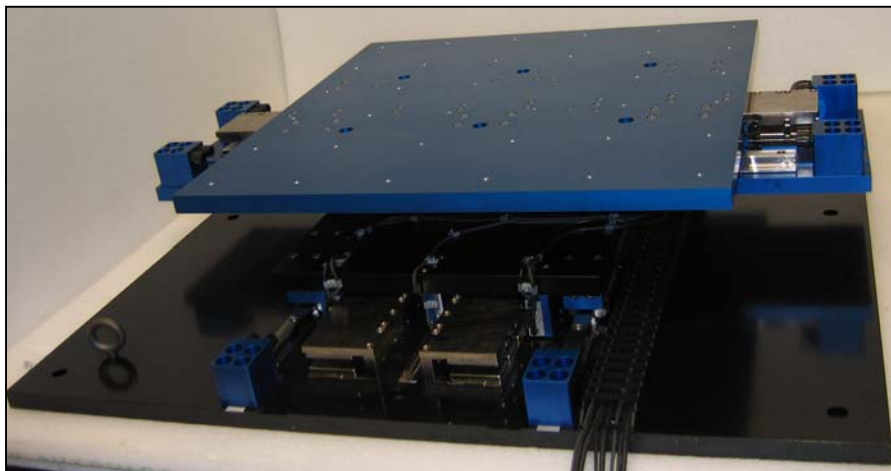

XY Gantry (High Force)

X-Axis = 8.50" stroke, 395 lbs cont. force, 1 μm encoder resolution

Y-Axis = 8.50" stroke, 198 lbs cont. force, 1 μm encoder resolution

*X-Axis has dual linear motors



Long Stroke Dual Encoders

120" stroke, 20 lbs cont., 60 lbs peak force

*Two encoder resolutions, 1 μm & 5 μm



High Force

30" stroke, 160 lbs cont., 450 lbs peak force,

1 μm encoder resolution

SINGLE RAIL POSITIONING STAGE

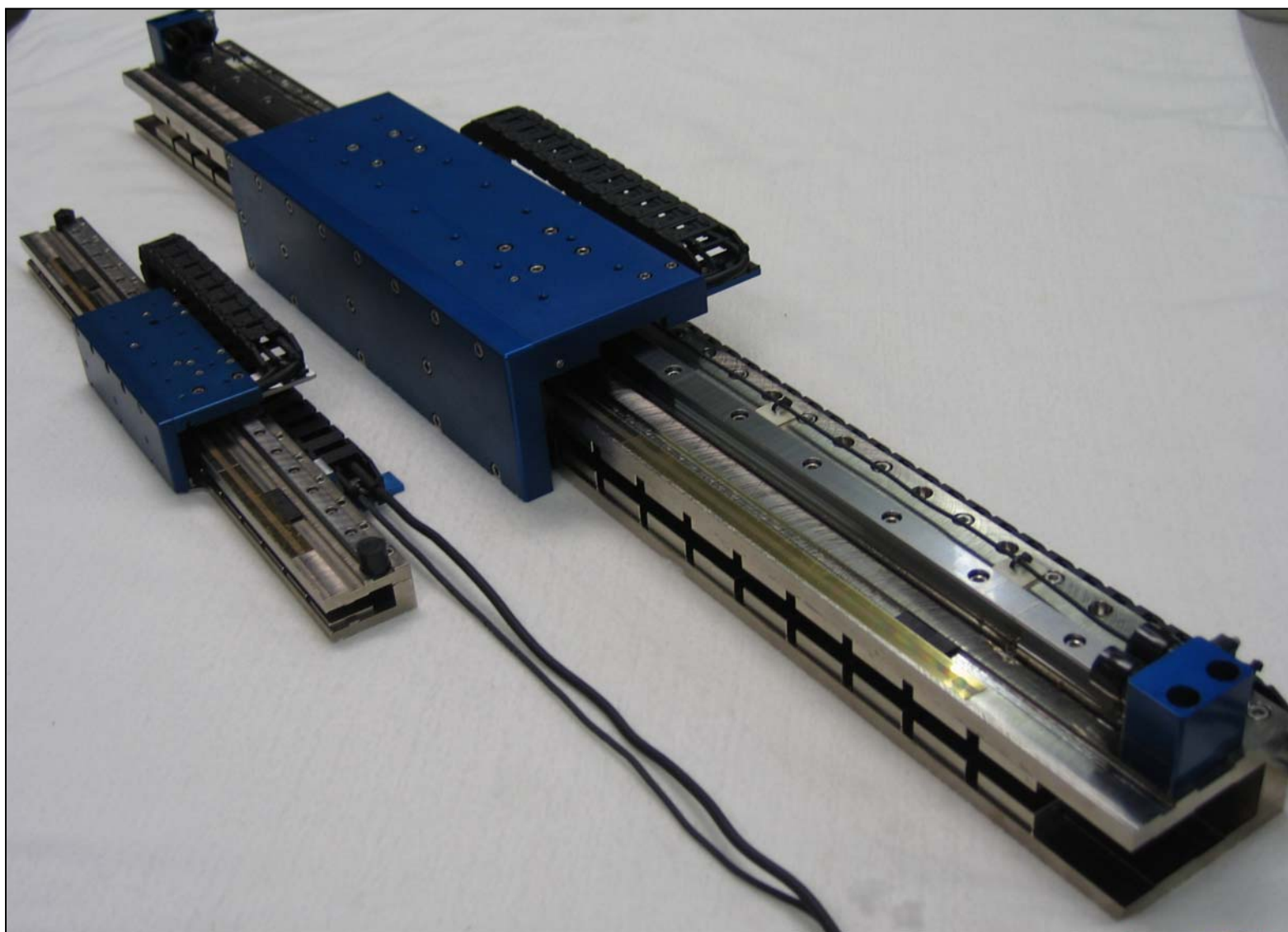

SR Positioning Stage

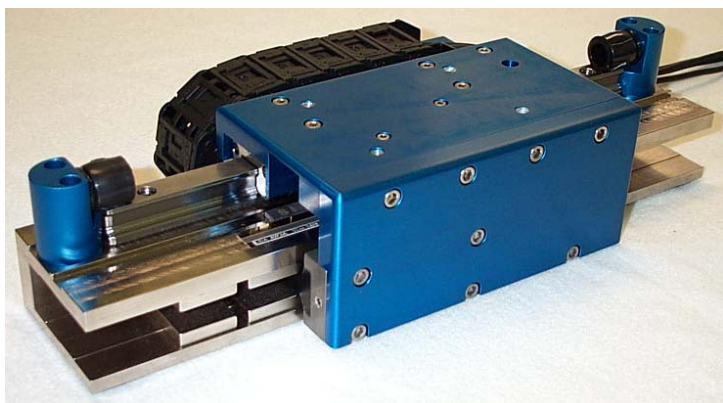

Travel	120 inches	[3 m]
Velocity	240 inches / sec	[6 m/s]
Acceleration	12 G's	12 G's
Peak Force	550 lbs	[2444 N]
Continuous Force	165 lbs	[733 N]
Resolution	.00004" or .0002"	[1 or 5 micron]

The SR stage is a compact, small footprint, open type positioning stage. It is used in closed loop positioning applications that require high speed and high accelerations of lighter loads.

The ironless core coil assembly has no magnetic attractive force to the stationary magnet assembly, which reduces the load on and increases life of the bearing system.

The low overall weight of the stage makes it ideal as a Y axis (top axis) in a multi-axis system. The lower moving mass of the stage allows for much higher accelerations of light payloads.

The cable carrier is oversized to allow for passage of customer payload cables and hoses. The back of the cable carrier can be easily removed and reattached to route through additional cables.

Advantages:

- Small Footprint and cross section
- Lowest weight per unit length
- Low cost
- High Acceleration of light loads
- High Speed

Applications:

- Pick and Place
- Vision Inspection
- Parts transfer
- Clean room

The SR positioning stage incorporates the latest in linear motion technology:

- **Motors:** Non-contact 3 Phase Brushless Linear Motor, Ironless Core, commutated either sinusoidally or trapezoidally with Hall Effects. The encapsulated coil assembly moves and the multi pole permanent magnet assembly is stationary. The lightweight coil assembly allows for higher acceleration of light payloads.
- **Bearings:** Linear guidance is achieved by using a single linear rail with 1 or 2 linear recirculating ball bearing guides. The bearing is sealed with wipers to contain the lubrication and to keep out debris.
- **Encoders:** Non-contact glass or metal scale optical linear encoders with a reference mark for homing. Multiple reference marks are available and are spaced every 50 mm down the length of the scale. Typical encoder output is A and B square wave signals but sinusoidal output is available as an option
- **Limit Switches:** End of travel limit switches are included at both ends of the stroke. The switches can be either active high (5V to 24V) or active low. The switches can be used to shut down the amplifier or to signal the controller that an error has occurred. The limit switches are typically an integral part of the encoder, but can be mounted separately if required.
- **Cable Carriers:** Cable guidance is achieved by using a cable carrier. Cable carriers are oversized to allow for routing of customers hoses and cables
- **Bellows:** The SR does not come with bellows.
- **Hard Stops:** Hard stops are incorporated into the ends of the stage to prevent over travel damage in the event of servo system failure.

Required Electronics:

The motor requires a 3 phase brushless amplifier with power supply, that is rated with sufficient current and voltage to meet the motion requirements. The inductance of the linear motor coil should be greater than the minimum load inductance of the servo amplifier. A programmable motion controller is required to close the position loop on the system.

Environmental Considerations:

The stage is a precision device with sensitive components, it should not be mounted in an environment that is wet or excessively dirty. The optical encoder scale is open and it should be kept free of debris in order to operate properly. The stationary magnetic assembly is highly magnetic, it should not be placed in an area where loose steel particles can be drawn into the magnetic gap.

The stage must not be mounted in an environment with high ambient temperatures.

Mounting:

The stage should be mounted to flat and stiff surface. Counter bored thru holes are present in the stage to allow for the mounting of the stage to the customers system. The moving table assembly has threaded holes on the top surface for attaching the payload. The stage may be mounted in any orientation. When mounting the stage with the table moving vertical, it should be noted that the stage will be required to generate additional force due to gravity and that the stage will slide down to the bottom hard stop when power fails.

Maintenance:

The ball bearing guides in the stage should be periodically lubricated with the manufacturers recommended grease. The open glass encoder scale should be wiped with a glass cleaner occasionally to ensure trouble free operation.

Ordering Info:

H2W Technologies, Inc 28310C Ave Crocker Valencia, CA 91355 USA
(888)-702-0540 (661)-702-9346 Ph (661)-702-9348 Fax
www.h2wtech.com info@h2wtech.com

Stages can be ordered for any stroke up to 120inches and any continuous force up to 47 lbs. The stages are built as the orders are placed, they are not stocked, as each customer requirement is different.

Ordering Info:

Stages can be ordered for any stroke up to 120inches and any continuous force up to 165 lbs. The stages are built as the orders are placed, they are not stocked, as each customer requirement is different.

Model #

SRS – AAA – BB – CCC - D

where: AAA is the stroke in inches (36 inch stroke is -036)
 BB is the width of the stage (5 inch width is -05)
 CCC is the continuous force (47 lbs is -047)
 D is for special options

(i.e. SRS-036-05-047-0 is a 5" wide SR stage with a 36" stroke, 47 lbs of continuous force and no special options)

Specifications:

Flatness	±.0012" /ft	±99 micron / meter
Straightness	±.0013" /ft	±104 micron / meter
Accuracy*	±.0007" /ft	±68 micron / meter
Repeatability*	±.0004"	±10 micron
Load Capacity	55 lbs	25 Kg

(*Encoder dependent)

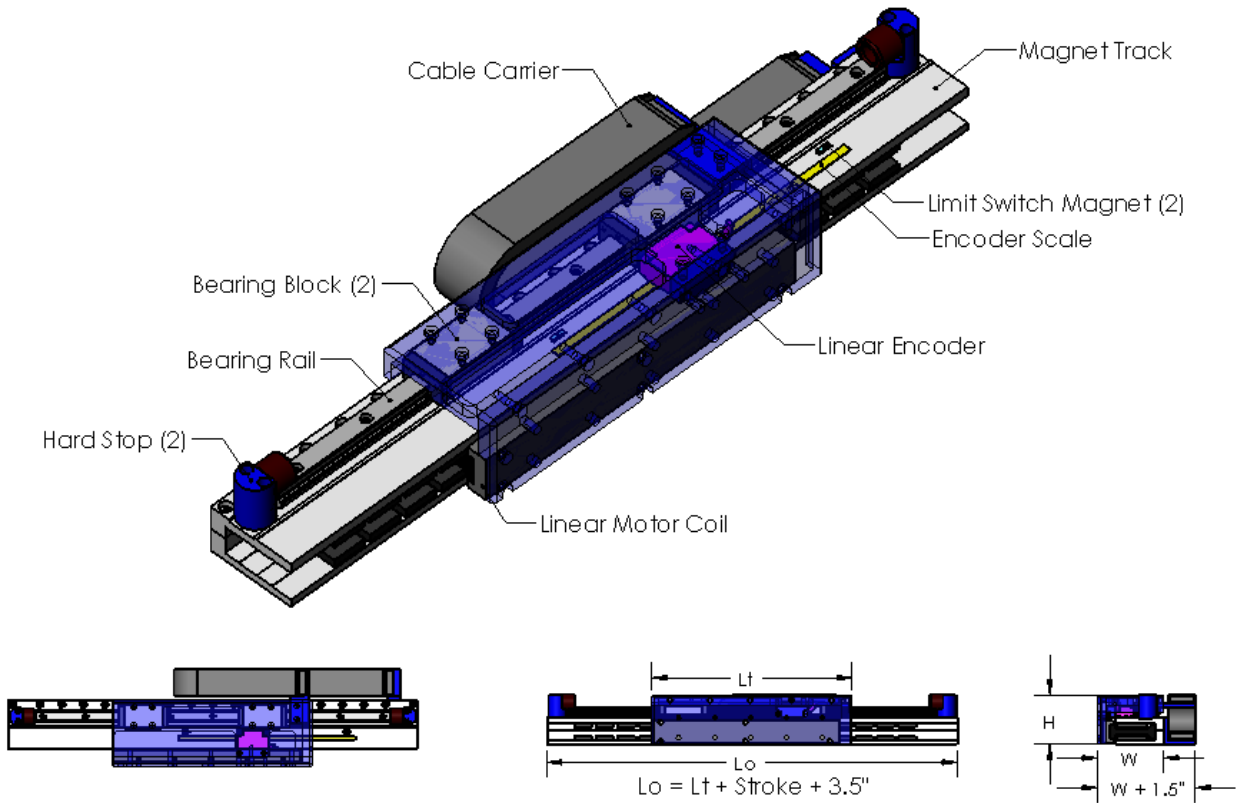

Model #	Stage Width (W)	Stage Height (H)	Table Length (Lt)	Continuous Force	Peak Force
SRS-XXX-04-020A	3.85" [98 mm]	3.00" [76 mm]	6.35 [161 mm]	20 lbs [89 N]	80 lbs [356 N]
SRS-XXX-04-030A	3.85" [98 mm]	3.00" [76 mm]	8.75 [222 mm]	30 lbs [134 N]	120 lbs [533 N]
SRS-XXX-04-040A	3.85" [98 mm]	3.00" [76 mm]	11.15 [283 mm]	40 lbs [178 N]	160 lbs [711 N]
SRS-XXX-04-050A	3.85" [98 mm]	3.00" [76 mm]	13.55 [344 mm]	50 lbs [222 N]	200 lbs [889 N]
SRS-XXX-04-060A	3.85" [98 mm]	3.00" [76 mm]	15.95 [405 mm]	60 lbs [262 N]	240 lbs [1067 N]
SRS-XXX-05-075A	4.95" [126 mm]	3.35" [85 mm]	15.30 [389 mm]	75 lbs [333 N]	250 lbs [1111 N]
SRS-XXX-05-125A	4.95" [126 mm]	3.35" [85 mm]	22.00 [559 mm]	125 lbs [556 N]	415 lbs [1844 N]
SRS-XXX-05-150A	4.95" [126 mm]	3.35" [85 mm]	28.75 [730 mm]	150 lbs [667 N]	550 lbs [2444 N]

SR STAGE

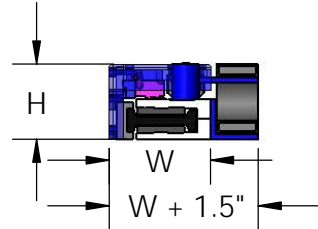
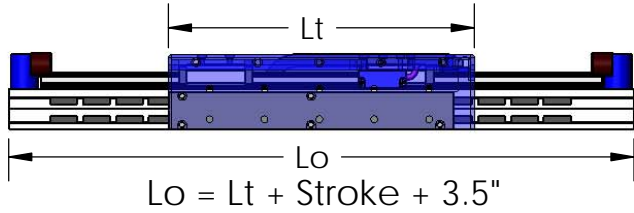
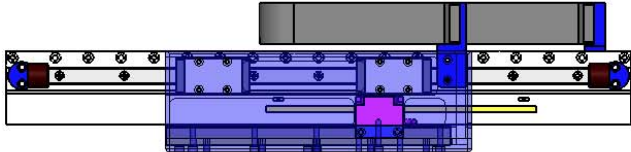
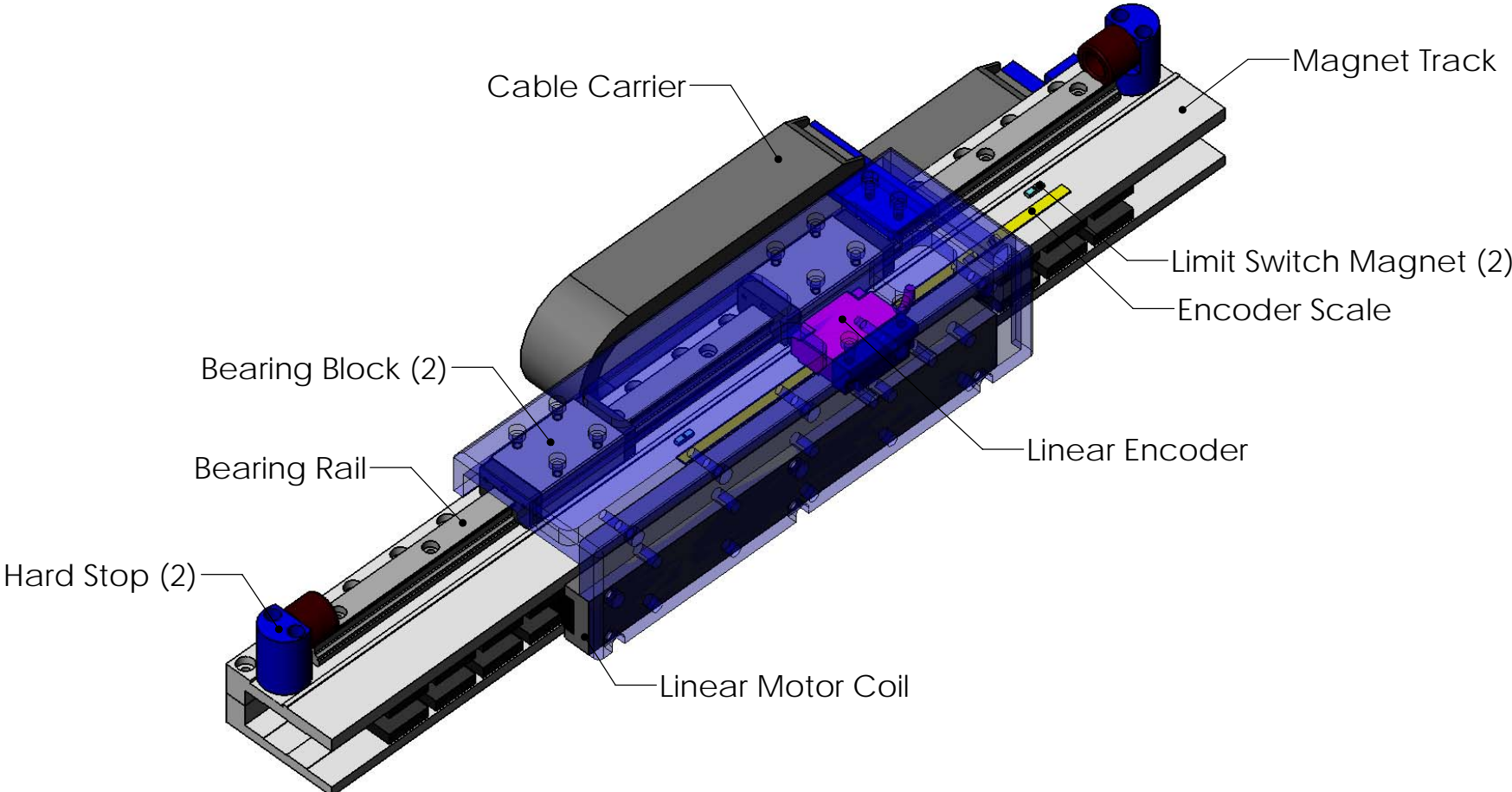

FORCE LEVEL 1

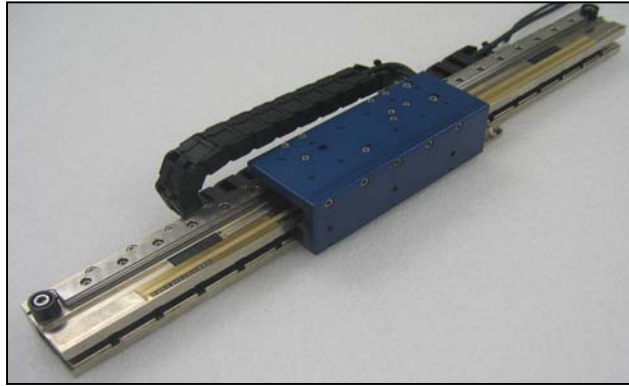

18" stroke
10 lbs cont.
40 lbs peak

FORCE LEVEL 2

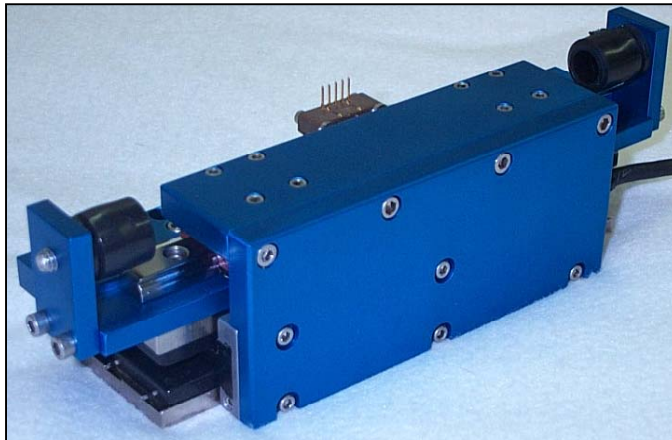

2" stroke
13 lbs cont.
52 lbs peak

FORCE LEVEL 3

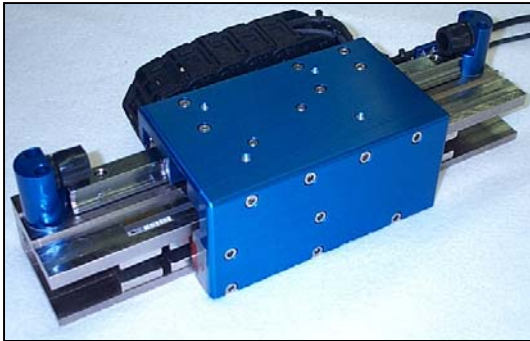

3" stroke
20 lbs cont., 80 lbs peak

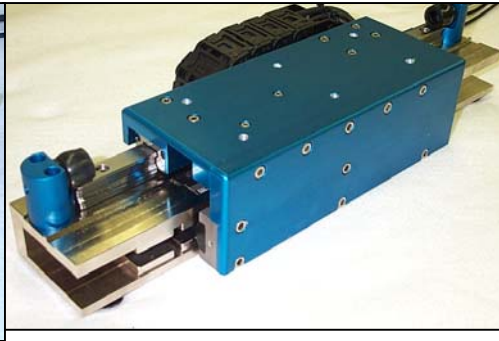

3" stroke
30 lbs cont., 120 lbs peak

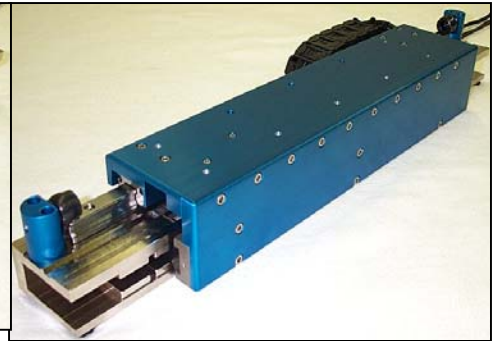

3" stroke
60 lbs cont., 180 lbs peak

FORCE LEVEL 4

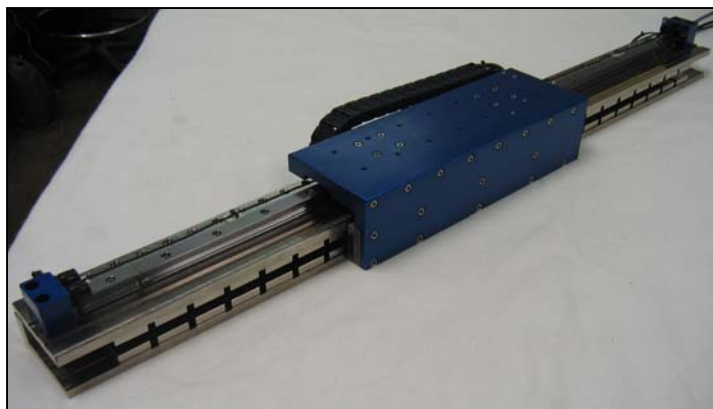

20" stroke
100 lbs cont.
400 lbs peak

CROSS ROLLER POSITIONING STAGE

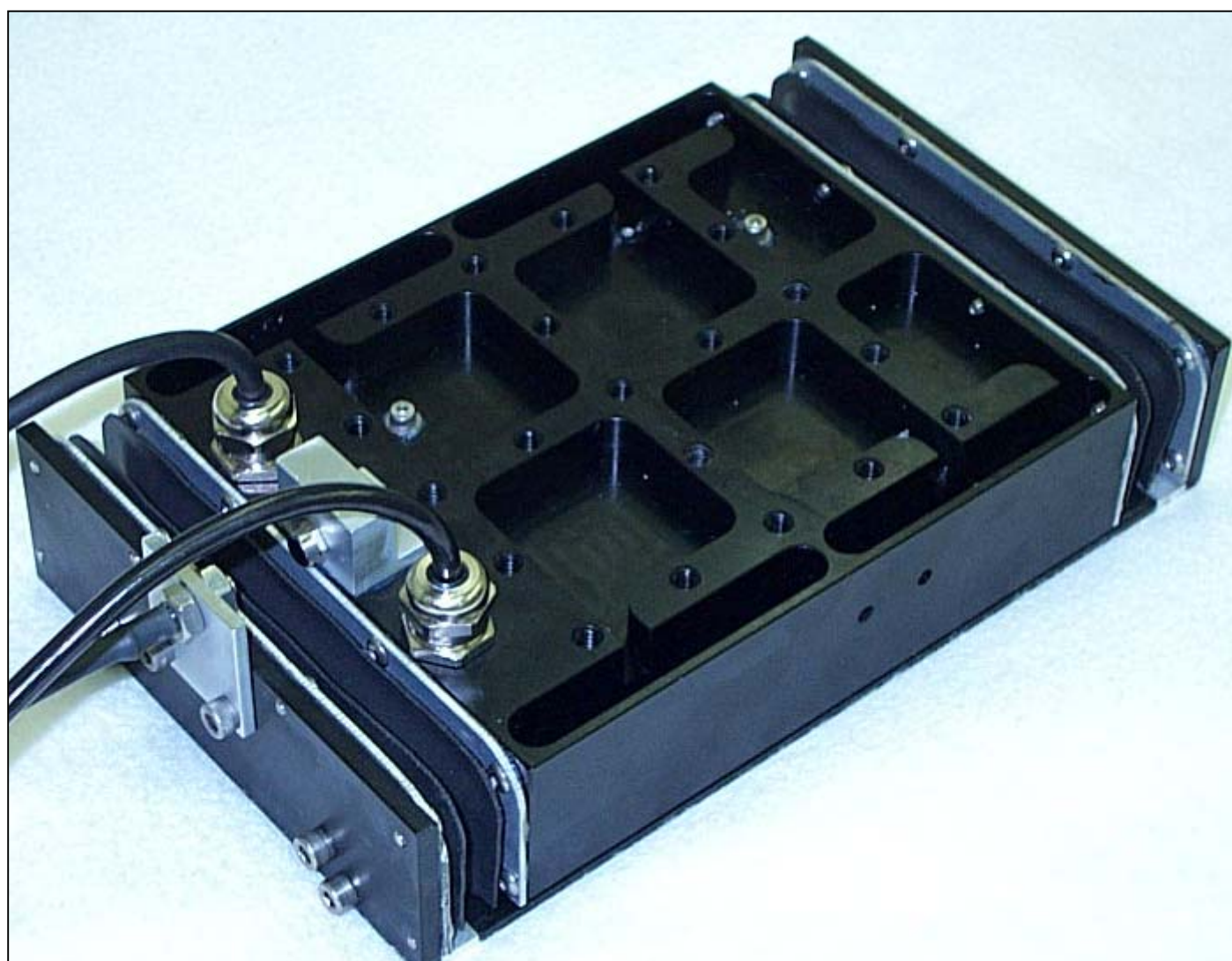

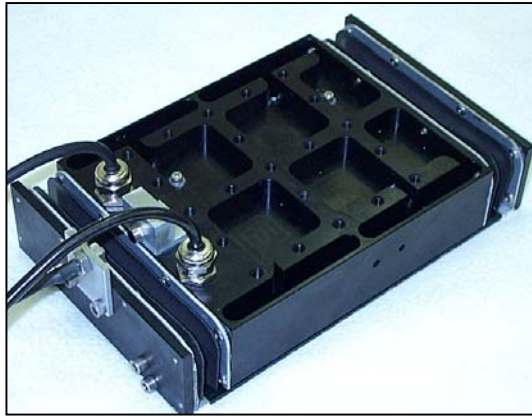

XR Positioning Stage

Travel	12 inches	[0.3 m]
Velocity	100 inches / sec	[2.5 m/s]
Acceleration	9 G's	9 G's
Peak Force	240 lbs	[1067 N]
Continuous Force	71 lbs	[316 N]
Resolution	.00004", .0002"	[1,5 micron]

The XR Positioning Stage is a compact, small cross section open or enclosed positioning stage for short stroke linear servo applications (up to 12 inch stroke). It is driven by either an iron core or ironless core 3-phase brushless linear motor and guided by 2 sets of parallel cross roller bearings. The stage can be with enclosed end covers and a set of bellows.

For higher force applications an iron core brushless linear motor is used. In this case the moving coil assembly is magnetically attracted to the stationary magnet assembly, which provides a preload for the crossed roller bearing system. For lower force applications and where velocity ripple is a concern due to cogging, an ironless core brushless linear motor is used.

The dual parallel rail sets offer excellent load carrying capability.

The wide, low profile of the stage ensures a stable platform for the payload or as the bottom axis (X axis) of a stacked multi-axis system.

The small overall package size makes the XR stage ideal as a Y or Z-axis for short stroke positioning applications.

The XR stage comes standard without bellows (folded way covers), but they can be added as an option.

A cable carrier is not supplied with this stage because of the short stroke, but can be added as an option, if desired.

Advantages:

- Wider footprint, very stable platform
- Lowest Profile
- Ideal for short stroke servo applications
- Large load carrying capability
- Smooth Operation

Applications:

- Pick and Place
- Vision Inspection
- Parts transfer
- Clean room

The XR positioning stage incorporates the latest in linear motion technology:

• Motors:

- 1) Non-contact 3 phase brushless, low cogging, iron core linear motor, commutated either sinusoidally or trapezoidally with Hall Effects. There is a large magnetic attractive force, which provides a preload for the crossed roller bearing system. The encapsulated laminated coil assembly moves and the multi-pole single sided permanent magnet assembly is stationary.
- 2) Non-contact 3 Phase Brushless Linear Motor, Ironless Core, commutated either sinusoidally or trapezoidally with Hall Effects. The encapsulated coil assembly moves and the multipole permanent magnet assembly is stationary. The lightweight coil assembly allows for higher acceleration of light payloads

- **Bearings:** Linear guidance is achieved by using 2 parallel sets of crossed roller rails. The rollers and retainer are not sealed. Periodic lubrication of the guides is recommended.

- **Encoders:** Non-contact glass or metal scale optical linear encoders with a reference mark for homing. Multiple reference marks are

Required Electronics:

The motor requires a 3 phase brushless amplifier with power supply, that is rated with sufficient current and voltage to meet the motion requirements. The inductance of the linear motor coil should be greater than the minimum load inductance of the servo amplifier. A programmable motion controller is required to close the position loop on the system.

Environmental Considerations:

The stage is a precision device with sensitive components, it should not be mounted in an environment that is wet or excessively dirty. The optical encoder scale is open and it should be kept free of debris in order to operate properly. The stationary magnetic assembly is highly magnetic, it should not be placed in an area where loose steel particles can be drawn towards the open magnetic surfaces. The stage must not be mounted in an environment with high ambient temperatures.

available and are spaced every 50 mm down the length of the scale. Typical encoder output is A and B square wave signals but sinusoidal output is available as an option

- **Limit Switches:** End of travel limit switches are included at both ends of the stroke. The switches can be either active high (5V to 24V) or active low. The switches can be used to shut down the amplifier or to signal the controller that an error has occurred. The limit switches are typically an integral part of the encoder, but can be mounted separately if required.
- **Cable Carriers:** Non-standard can be added as an option.
- **Bellows:** Non standard can be added as an option
- **Hard Stops:** Hard stops are incorporated into the ends of the stage to prevent over travel damage in the event of servo system failure

Mounting:

The stage should be mounted to flat and stiff surface. Counter bored thru holes are present in the stage to allow for the mounting of the stage to the customers system. The moving table assembly has threaded holes on the top surface for attaching the payload. The stage may be mounted in any orientation. When mounting the stage with the table moving vertical, it should be noted that the stage will be required to generate additional force due to gravity and that the stage will slide down to the bottom hard stop when power fails.

Maintenance:

The cross roller bearings in the stage should be periodically lubricated with the manufacturers recommended grease. The open glass encoder scale should be wiped with a glass cleaner occasionally to ensure trouble free operation.

Ordering Info:

Stages can be ordered for any stroke up to 12 inches and any continuous force up to 71 lbs. The stages are built as the orders are placed, they are not stocked, as each customer requirement is different.

Model # XRS – AAA – BB – CCC - D

where: AAA is the stroke in inches (12 inch stroke is -012)
 BB is the width of the stage (9 inch width is -09)
 CCC is the continuous force (60 lbs is -060)
 D is for special options

(i.e. XRS-006-05-047-0 is a 5" wide SR stage with a 6" stroke, 47 lbs of continuous force and no special options)

Specifications:

Flatness	±.0005" /ft	±41 micron / meter
Straightness	±.0005" /ft	±41 micron / meter
Accuracy*	±.0004" /ft	±33 micron / meter
Repeatability*	±.0002"	±16 micron
Load Capacity	100 lbs	45 Kg

(*Encoder dependent)

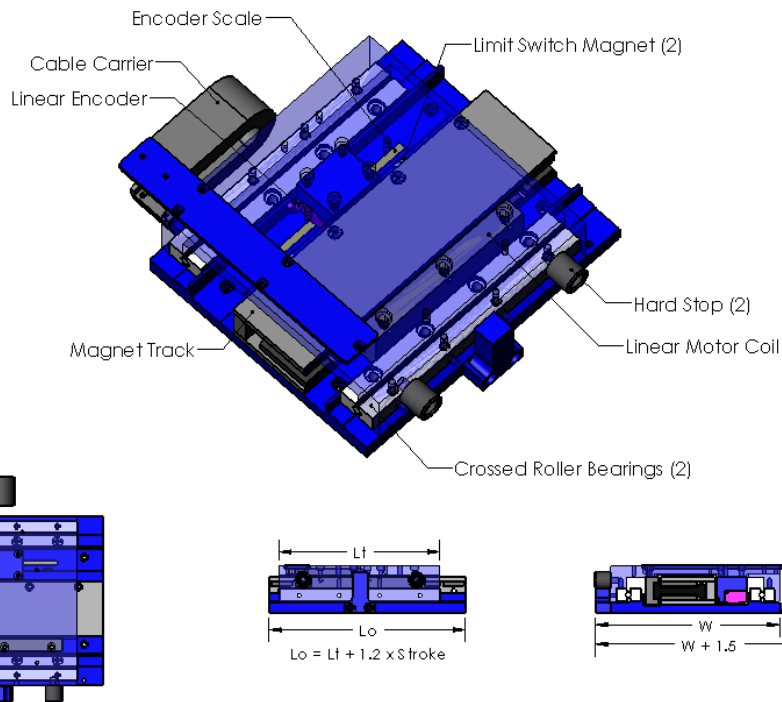

Model #	Stage Width (W)	Stage Height (H)	Table Length (Lt)	Continuous Force	Peak Force	Maximum Travel
XRS-XXX-06-006A	5.50" [140 mm]	1.75" [44 mm]	4.0 [102 mm]	6.5 lbs [29 N]	15 lbs [67 N]	2.5" [64 mm]
XRS-XXX-06-014A	5.50" [140 mm]	1.75" [44 mm]	6.5 [229 mm]	14 lbs [62 N]	30 lbs [133 N]	4.0" [102 mm]
XRS-XXX-06-019A	5.50" [140 mm]	1.75" [44 mm]	9.0 [356 mm]	19 lbs [84 N]	45 lbs [200 N]	5.5" [140 mm]
XRS-XXX-06-023A	5.50" [140 mm]	1.75" [44 mm]	11.5 [102 mm]	23 lbs [102 N]	60 lbs [267 N]	7.0" [178 mm]
XRS-XXX-08-013A	7.65" [194 mm]	2.00" [51 mm]	4.0 [102 mm]	13 lbs [58 N]	40 lbs [178 N]	2.5" [64 mm]
XRS-XXX-08-025A	7.65" [194 mm]	2.00" [51 mm]	6.5 [165 mm]	25 lbs [111 N]	80 lbs [356 N]	4.0" [102 mm]
XRS-XXX-08-036A	7.65" [194 mm]	2.00" [51 mm]	9.0 [229 mm]	36 lbs [160 N]	120 lbs [533 N]	5.5" [140 mm]
XRS-XXX-08-013A	7.65" [194 mm]	2.00" [51 mm]	11.5 [292 mm]	47 lbs [209 N]	160 lbs [711 N]	7.0" [178 mm]
XRS-XXX-08-059A	7.65" [194 mm]	2.00" [51 mm]	14.0 [356 mm]	59 lbs [262 N]	200 lbs [889 N]	9.5" [241 mm]
XRS-XXX-08-071A	7.65" [194 mm]	2.00" [51 mm]	16.0 [102 mm]	71 lbs [316 N]	240 lbs [1067 N]	11.0" [279 mm]

XR STAGE

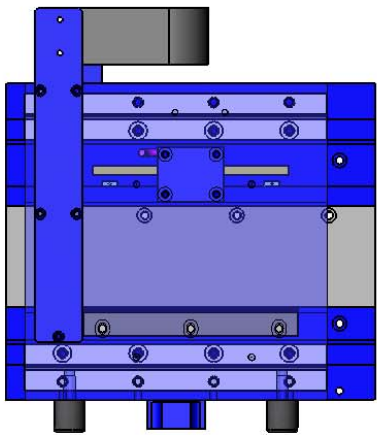
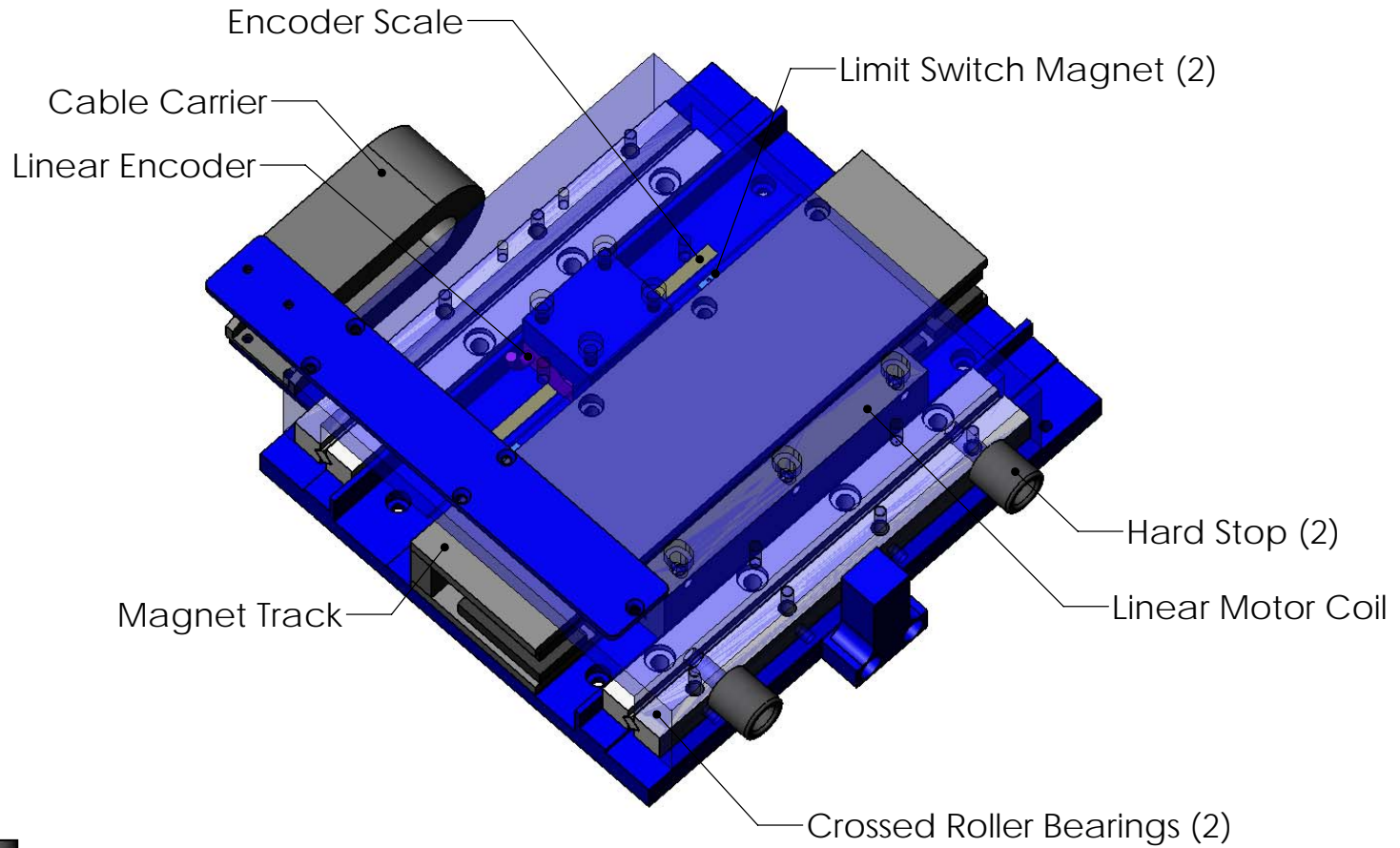

TOP

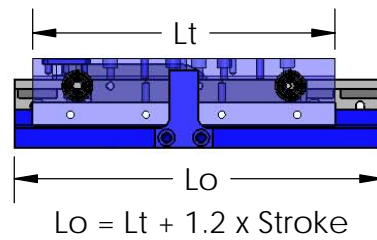

SIDE

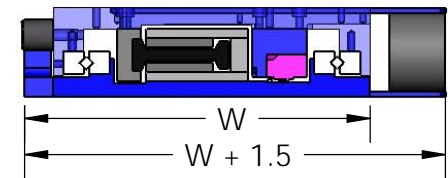

FRONT



H2W Technologies, Inc.

28310-C Ave Crocker • Valencia, CA 91355
E-mail: info@h2wtech.com
Call Toll Free: 888.702.0540
Phone: 661.702-9346 • Fax: 661.702.9348

Innovation in Linear Motion

Spline Shaft Screw Driven Positioning Stage

Model Shown : SCS-023-04-010-S

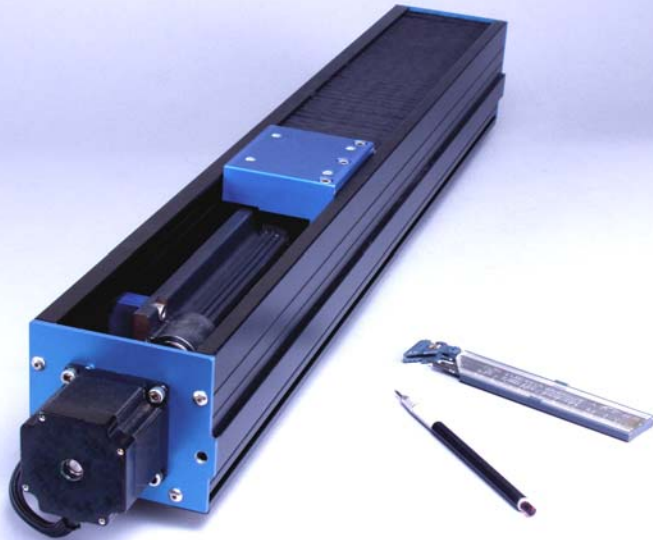

SPECIFICATIONS:

Travel	= Up to 96 inches
Speed	= Up to 30 inches / sec
Maximum Payload	= 100 lbs.
Resolution	= Up to 1 micron.
Straightness	= 0.003 inches/foot
Screw Accuracy	= 0.005 inches/foot
Angular Yaw	= 3 degrees / foot
Repeatability (Bi-directional)	= 50 micro inches

These stages feature exceptionally long life without the need of adjustment, lubrication or maintenance. The integration of a splined linear guide and leadscrew results in a torsionally stiff stage that can be operated in either a horizontal or vertical axis. These stages are ideal for: Pick-and-place, parts transfer, water jet cutting, laser cutting and laser etching, inspection, testing, packaging, and assembly applications.

Designed for loads up to 100 lbs. (45 Kg) and speeds to 30 in/sec. (762 mm/sec) the stages can be specified in compound multi-axis configurations such as an X-Y-Z axis gantry robot. To suit the requirements of an application a variety of stepper motors, DC brush and brushless motors, or AC motors can be mounted to the stage.

Options to enhance performance and ease integration into a new or existing application are: Custom drilled and/or tapped holes in the stage and/or carriage, end of travel limit switches which can disable the amplifier, linear encoder, cable carrier, and protective bellows.

To find similar products please visit our website at: <http://www.h2wtech.com>.

For help with this product, or selecting the proper linear motion product for your application please call us at 888.702.0540 or e-mail us at info@h2wtech.com.

These drawings and specifications are the property of H2W Technologies, Inc. They are issued in confidence and shall not be reproduced, copied, or used without written permission from H2W Technologies, Inc. (www.h2wtech.com)

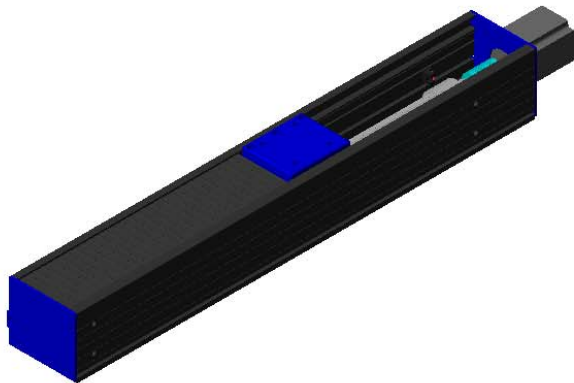
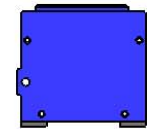
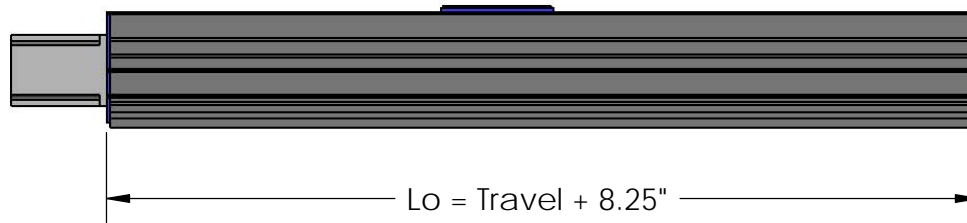
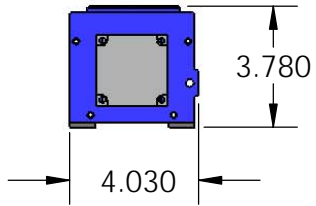
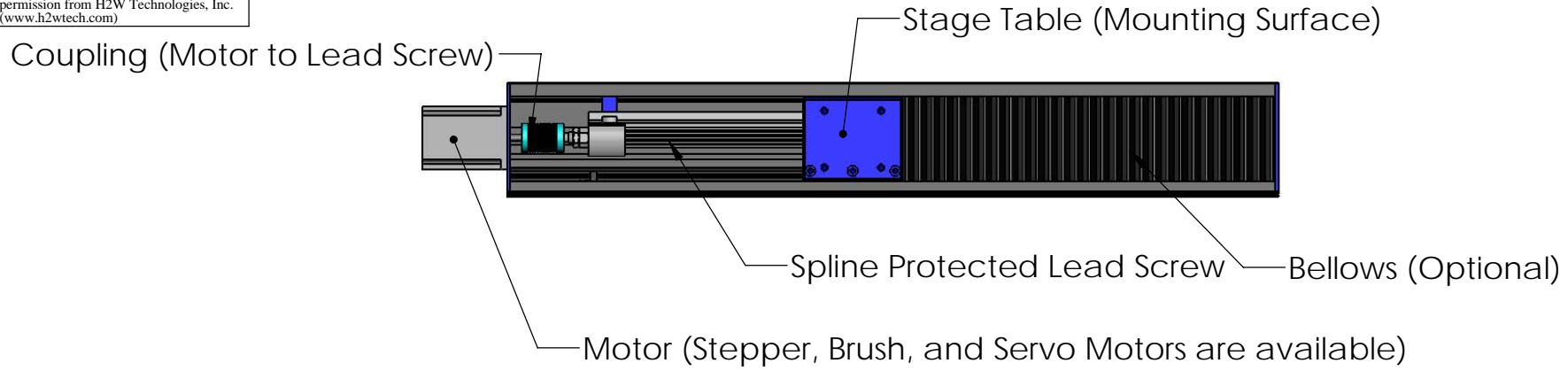

H2W Technologies, Inc.

28310-C Ave Crocker Valencia, CA 91355 USA
Tel: (661)-702-9346 Fax: (661)-702-9348
www.h2wtech.com

UNLESS SPECIFIED OTHERWISE:
All dimensions are in inches
Standard Tolerances are as follows
.XXX ±.005 ANGLES ±1°
.XX ±.010 FILLETS .010
.X ±.020 CORNERS .010
Remove All Burrs and Sharp Edges

MATERIAL			
FINISH			
DRAWN	DATE	APPROVED	DATE
OOG	1-12-05	MPW	1-12-05

TITLE Spline Shaft Screw Driven Positioning Stage

DWG # 44-0043	REV	SHEET 1 of 1
----------------------	------------	---------------------

SC Stage

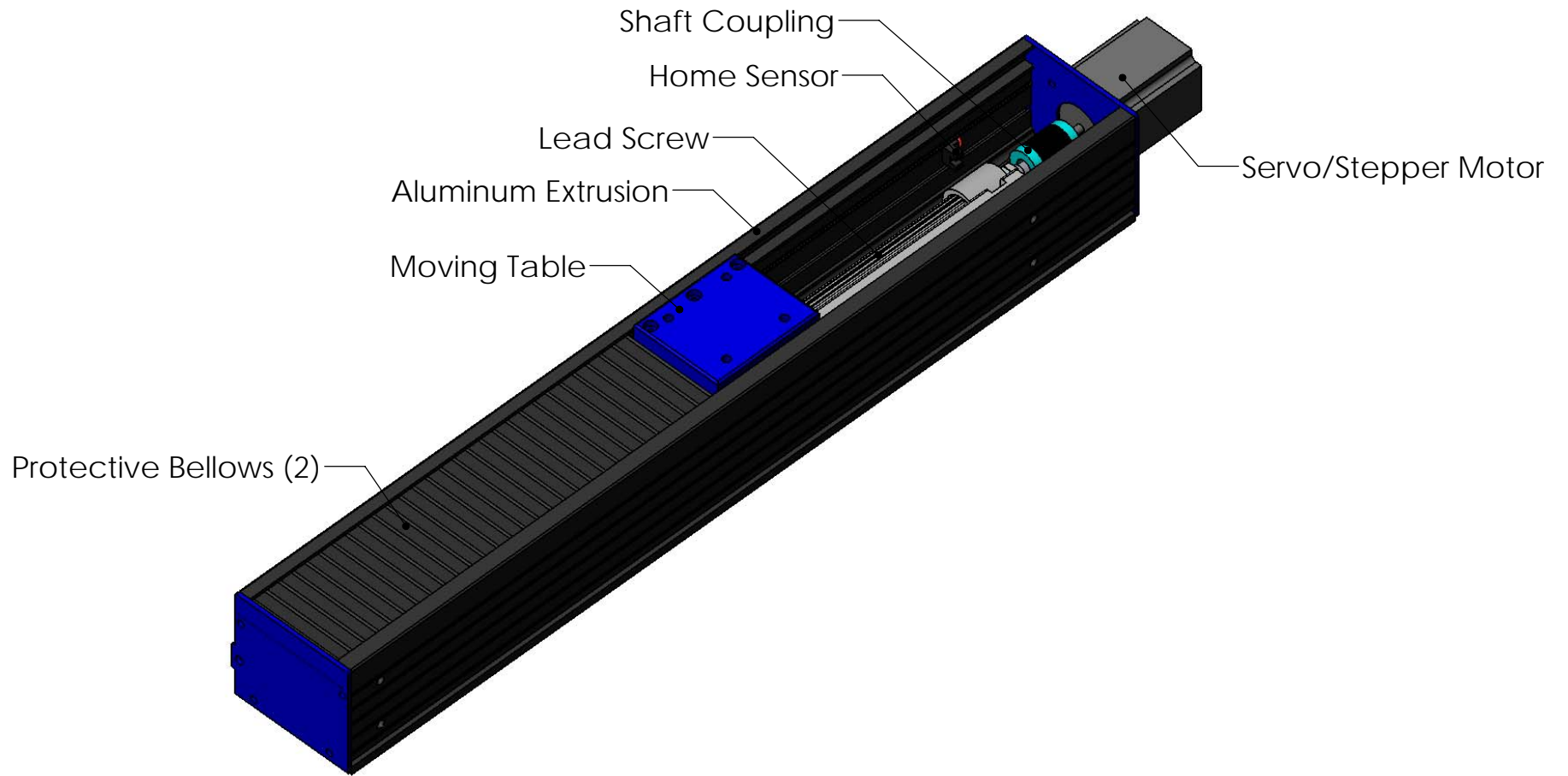

TOP

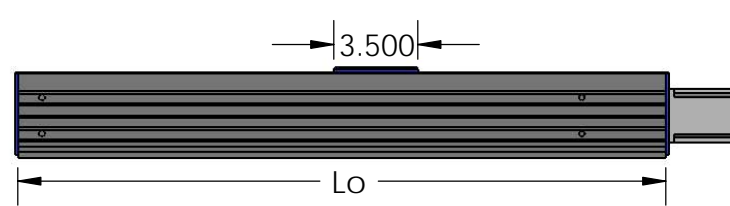

SIDE

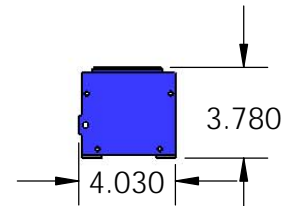

FRONT

LINEAR STEPPER MOTOR

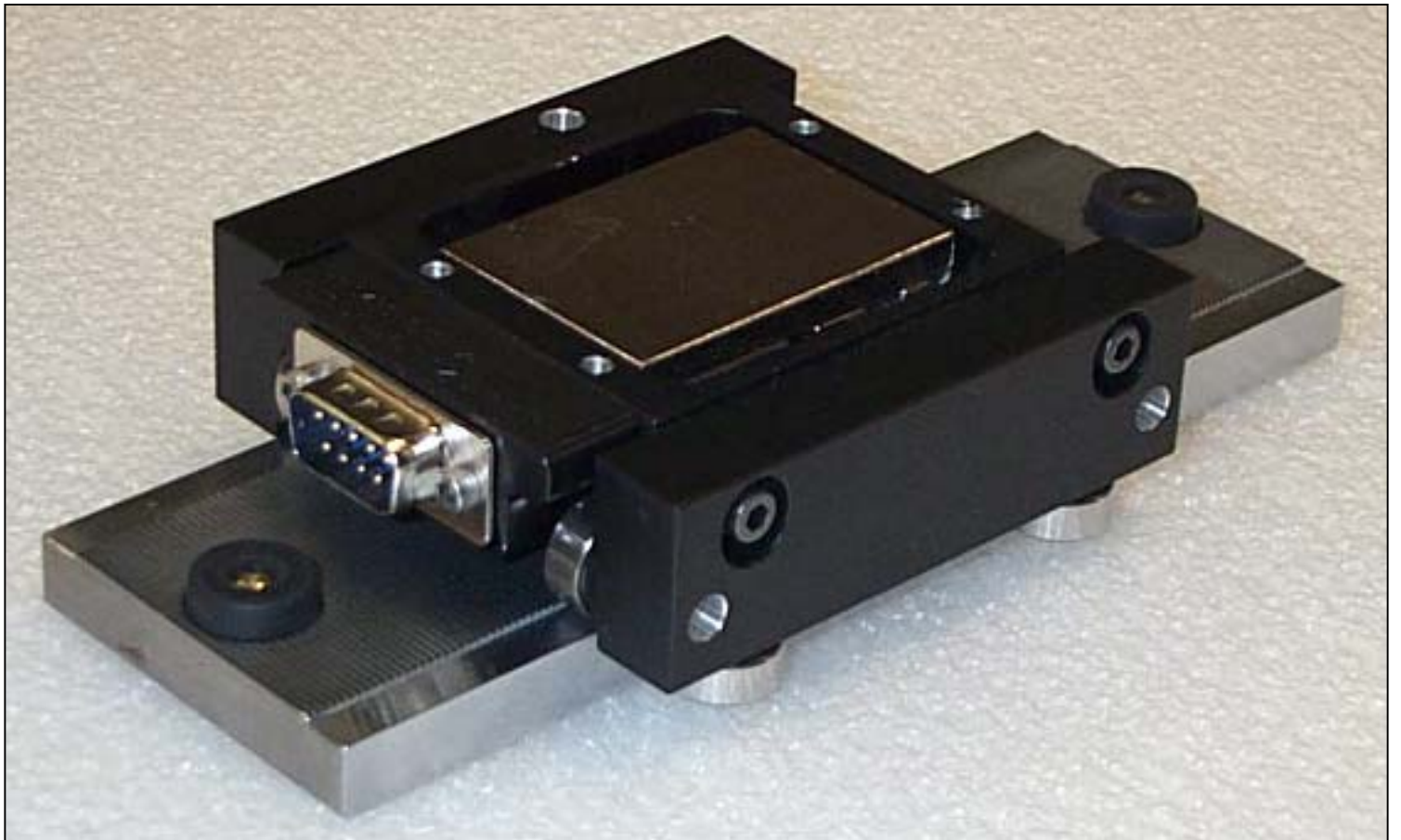

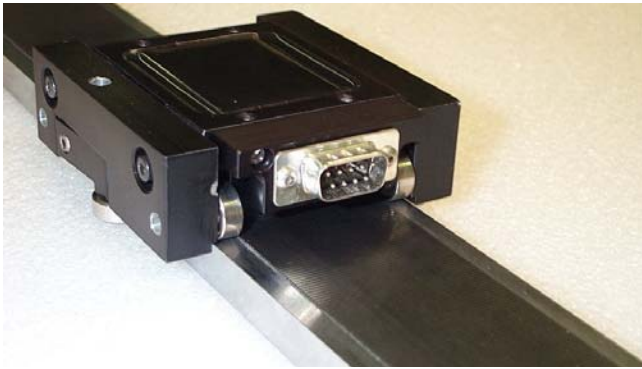

Travel	144 inches	[3.6 m]
Velocity	80 inches / sec	[2 m/s]
Acceleration	1 G	1 G
Peak Force	65 lbs	[289 N]
Continuous Force	50 lbs	[222 N]

H2W Technologies linear stepper motors are ideal for open loop positioning applications with light payloads. They can be used at speeds up to 80 in /sec [2 m/sec] and strokes up to 144" [3.6 m]. Linear stepper motors are capable of very precise position, velocity and acceleration control when coupled with a microstepping drive and indexer.

The short moving assembly called a "forcer" is guided by either roller or air-bearings along the precision ground track called a "platen". The bearings are designed to support the customer's payload and to maintain the required .001" [0.025 mm] gap between the platen and the forcer.

The step and direction signal from a microstepping drive, to the 2 or 4 phase forcer is supplied via a power cable. The motion achieved with a full step is .010" [250 microns] and with a microstep it's .00004" [1 micron].

The linear stepper motor is a complete positioning stage with the motor, the bearings and the positioning system all built into one compact package.

Integrating a linear encoder with the stepper provides a closed loop system.

Advantages:

- Low profile and small cross section
- High Speed
- Low cost positioning stage solution
- No servo tuning required
- Multiple forcers on a single platen

Applications:

- Pick and Place
- Wire bonders
- Parts transfer
- Fiber optic

The Linear Stepper Motor consists of 2 main parts

- **Moving Forcer Assembly:** The forcer is made up of an aluminum housing that contains the motor windings, lamination stacks, and permanent magnets. The active surface of the lamination is slotted to form teeth with a pitch of .040" [1 mm]. The ends of the coil are brought out to either a "D" connector or to flying leads. Mounting holes on the top surface of the forcer are for attaching the customer's payload. The forcer comes in different widths and lengths, depending on the required force. Multiple forcers can be supplied with a single platen to allow for independent moving heads.
- **Long Stationary Platen:** The platen is a precision ground steel bar or tube that is slotted to form .020" [0.50 mm] wide teeth on the surface. The bar is hard chrome plated and filled with epoxy to provide a flat air-bearing surface for the platen. The platen is available in widths from 1.25" to 3.0" [31.8 mm to 76.2 mm]. The length of the platen is a function of the stroke. Single piece platens are available as long as 144 inches [3.6 m]. For longer strokes the platens will be supplied in sections.

Required Electronics:

The linear stepper motor requires a full step or microstepping driver with power supply that is rated with sufficient current and voltage to meet the motion requirements. With full stepping, the forcer will move .010" [.25 mm] for each step. With microstepping the forcer will divide the full step by the number of microsteps. With 256 microsteps / full step, the microstep will be .010" [.25 mm] / 256 = 0.00004" [1 micron]

Environmental Considerations:

The linear stepper motor is a precision device and should not be mounted in an environment that is wet or excessively dirty. Debris should not be allowed to accumulate on the platen.

Mounting:

The platen should be mounted to a flat (better than .003"/ft [246 microns / m]) and stiff surface. Threaded holes on the bottom of the platen are present for mounting to the customer's system. The forcer has threaded holes on the top surface for attaching the payload. The linear stepper motor may be mounted in any orientation. When mounting the platen with the forcer moving vertical, it should be noted that the forcer will be required to generate additional force due to gravity and that the ball bearing forcer will slide down to the bottom when power fails. Turning off the air to an air bearing forcer will lock the forcer in place.

Ordering Info:

Linear stepper motors can be ordered for any stroke up to 144 inches and continuous forces up to 50 lbs [222 N]. Platens are available as bars, single piece tubes or welded tube assemblies

Model # STS-AABB-CX

where: AA is for the continuous force in lbs (06 is 6 lbs)

BB is the platen width (15 is 1.5 inch)

C is for the bearing type (R for roller bearing, A for air bearing)

X is for special options

(i.e. STS-0213-R is a 2.0 lbs continuous force stepper, designed for a 1.25" wide platen and no special options)

P/N STS-0213-R Linear Stepper

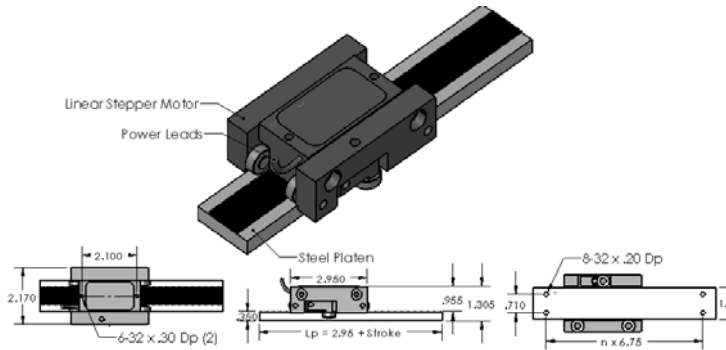

P/N STS-0620-R Linear Stepper

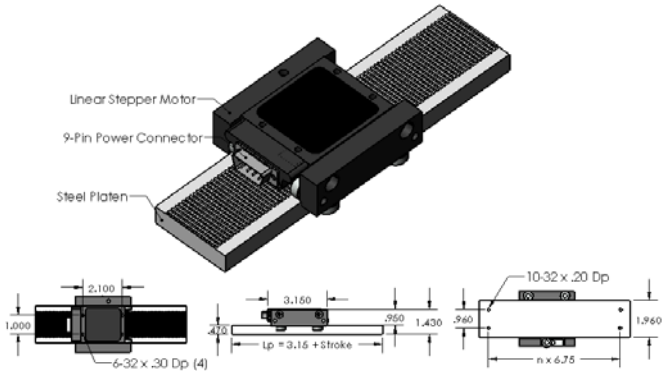

P/N STS-1220-A Linear Stepper

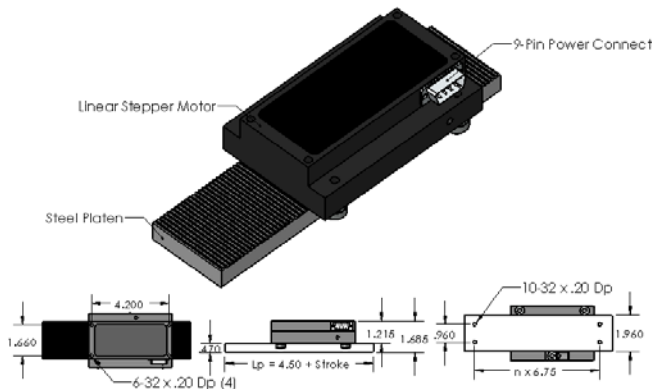

P/N STS-2030-A Linear Stepper

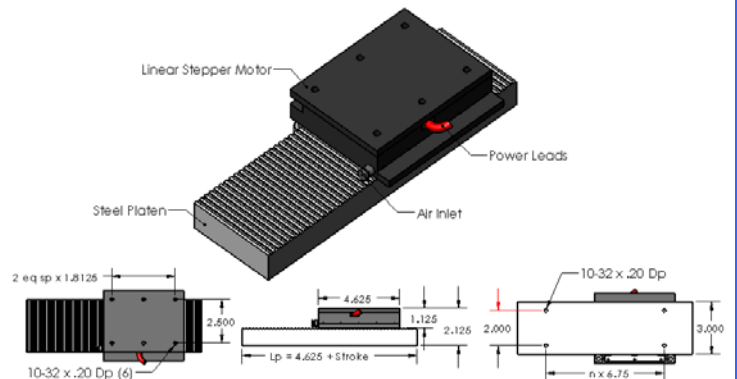

Lp = Platen Length

Model #	Force cont lbs [N]	Force peak lbs [N]	Current rms amps	Current peak amps	# of Phases	Bearing Type
STS-0213-R	2 [9]	2.3 [10]	2	3	2	Roller
STS-0620-R	6 [27]	8 [36]	1.6	3.5	2	Roller
STS-1220-A	12 [53]	16 [71]	3.2	7	2	Air
STS-2030-A	20 [89]	26 [115]	3.2	7	2	Air

Note: This is a partial listing; other models with different forces and strokes are available. H2W Technologies single axis linear steppers can be custom designed to meet your specifications. For detailed drawings see our website www.h2wtech.com or contact H2W Technologies at the numbers listed below.

2Lb Stepper

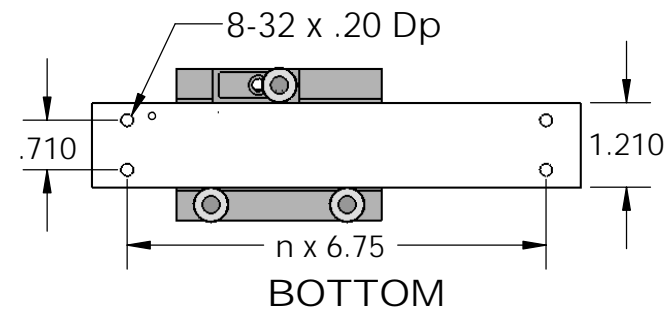
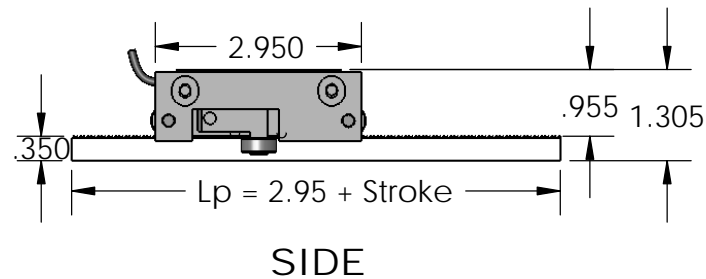
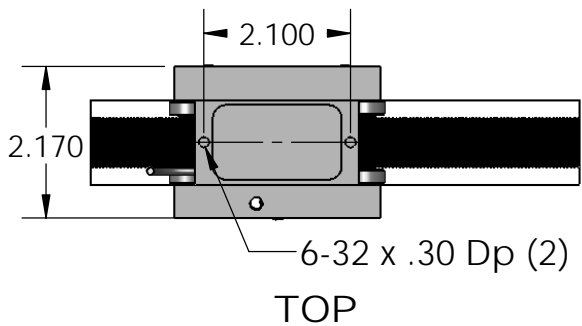
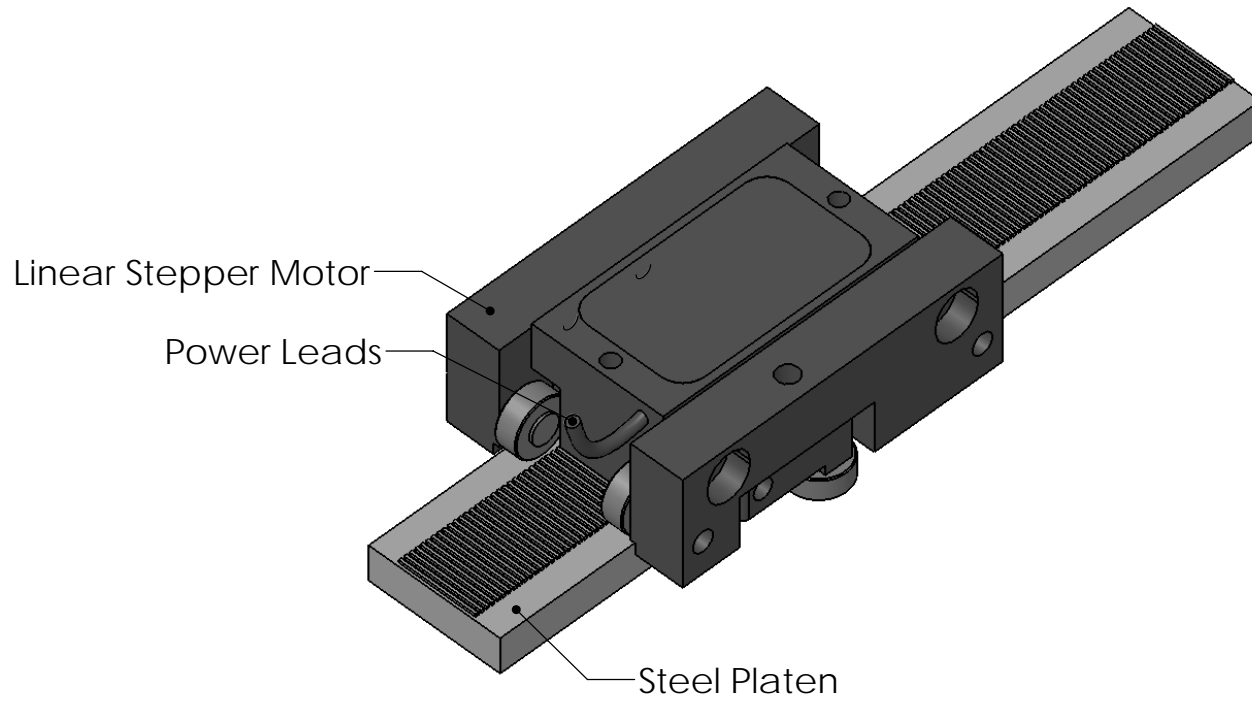

5Lb Stepper

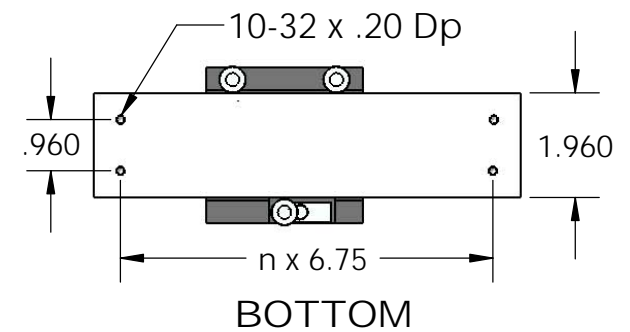
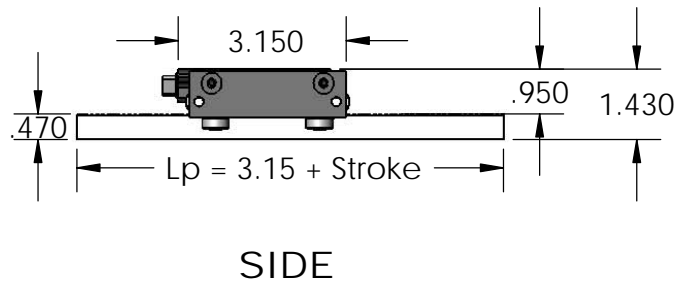
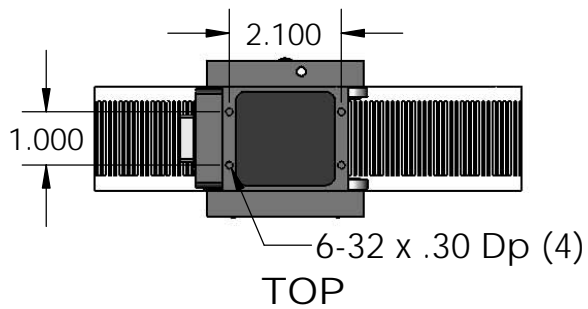
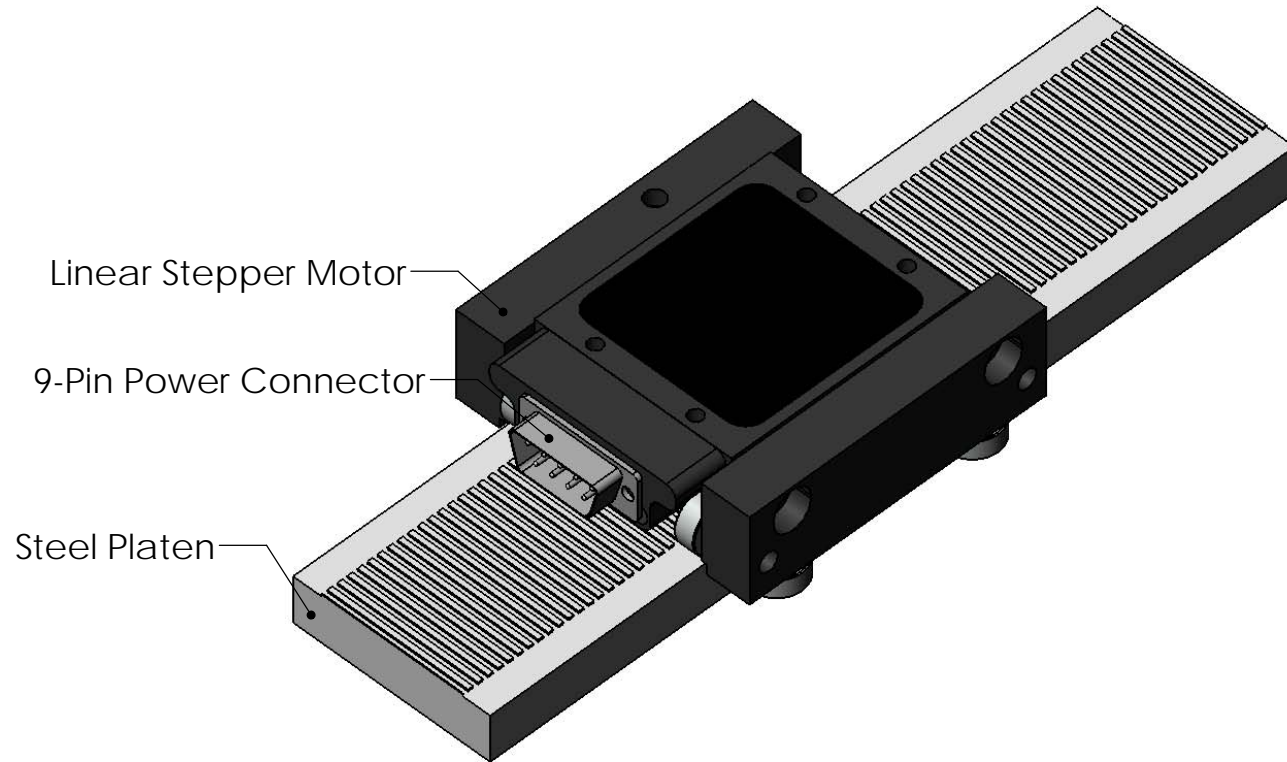

12Lb Stepper

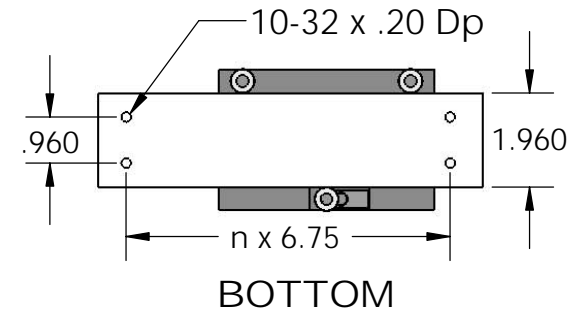
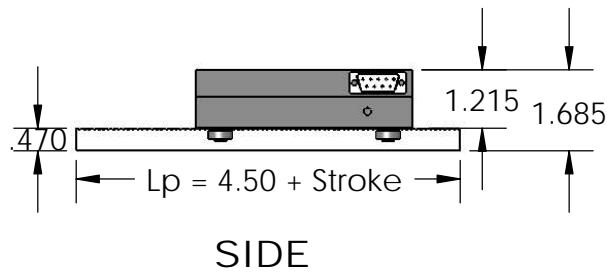
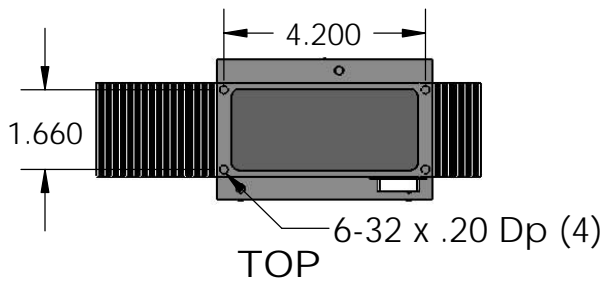
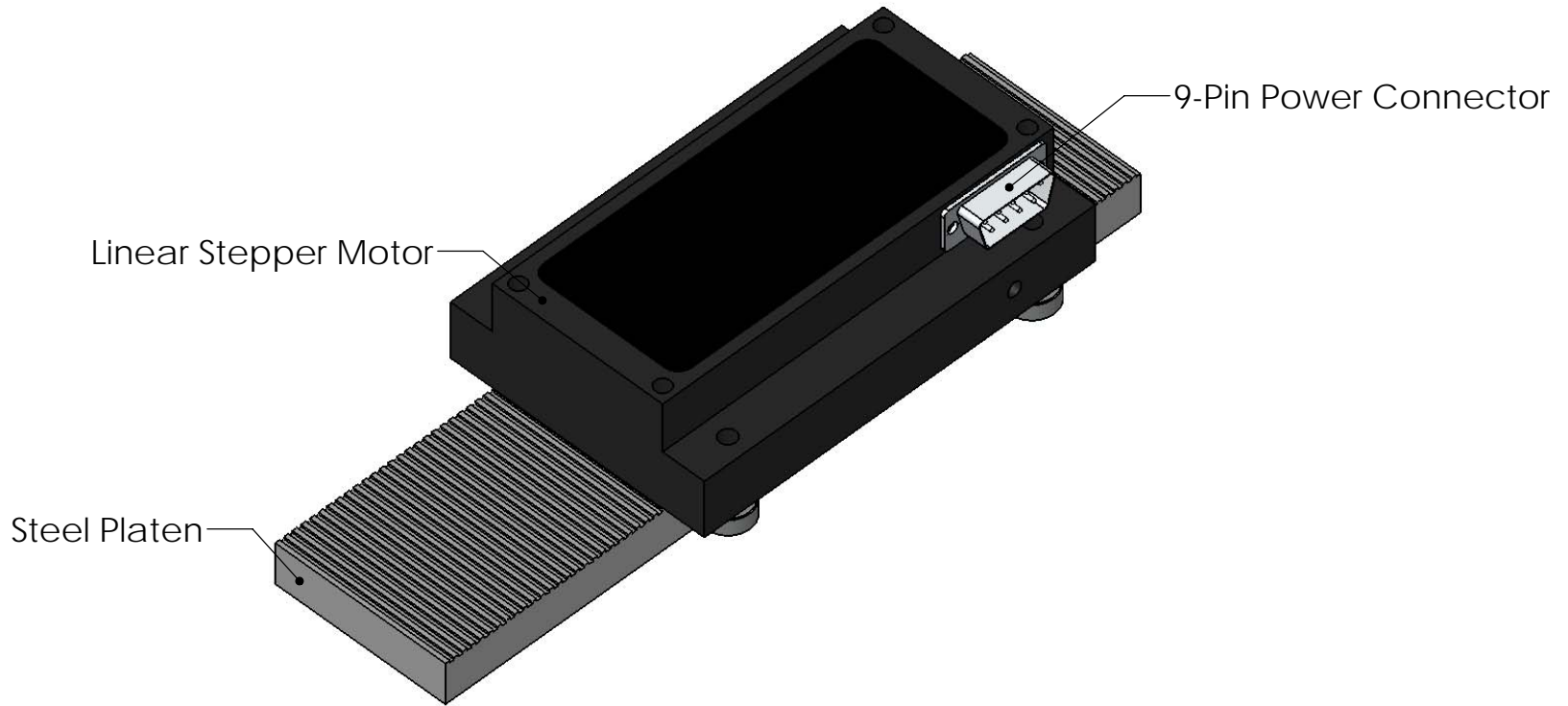

20Lb Stepper

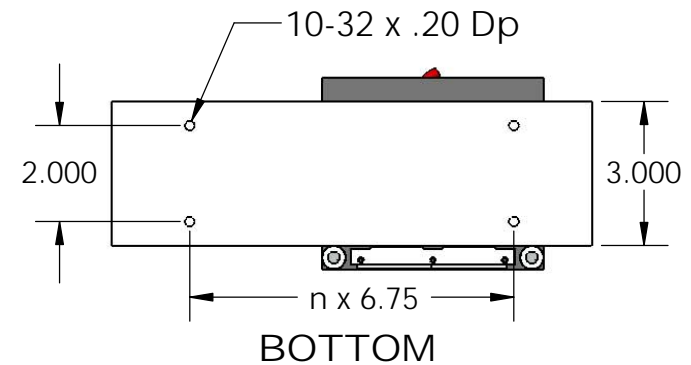
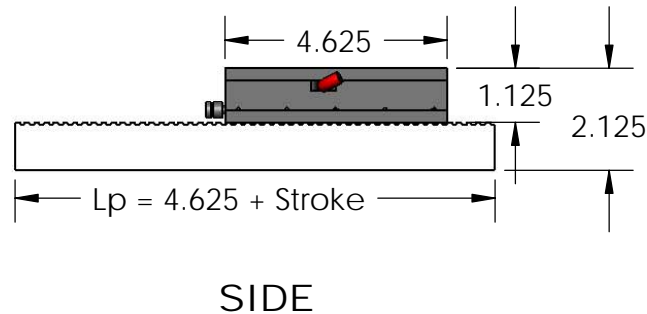
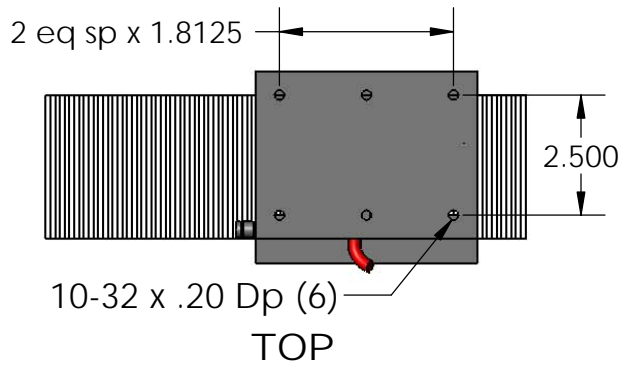
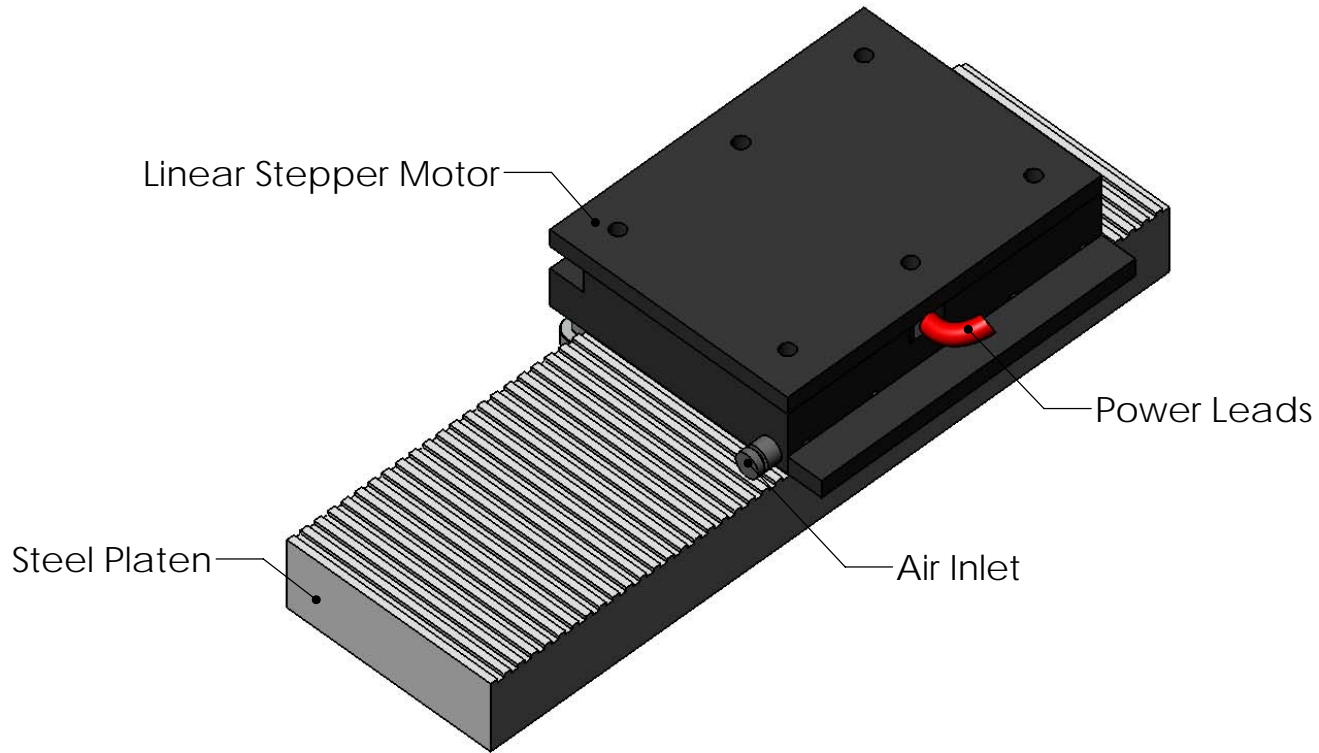

LINEAR STEPPER POSITIONING STAGES

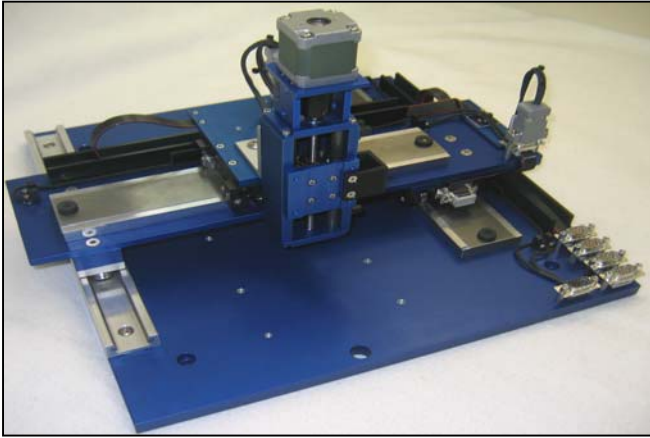

XYZ Gantry

X-Axis = 7.35" Stroke
Y-Axis = 7.35" Stroke
Z-Axis = 2.0" Stroke

*All axis have forward and reverse limit switches

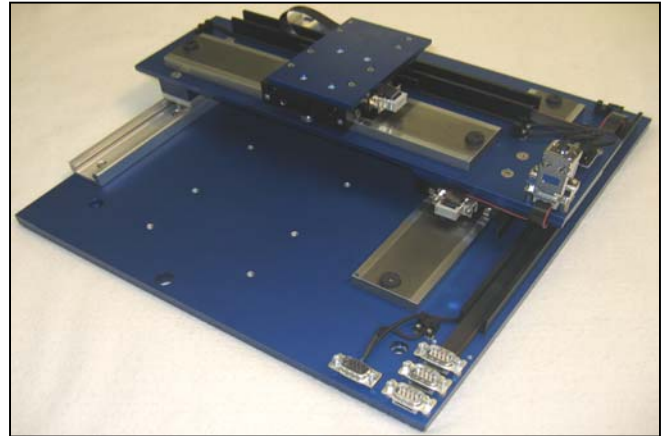

XY Gantry

X-Axis = 7.35" Stroke
Y-Axis = 7.35" Stroke

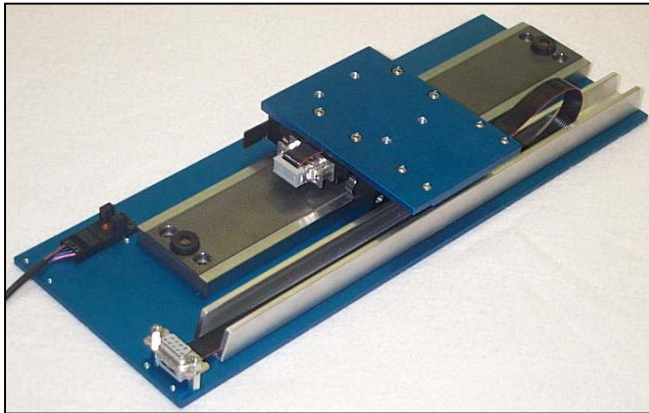

Single Positioning Stage

15" Stroke, Home switch

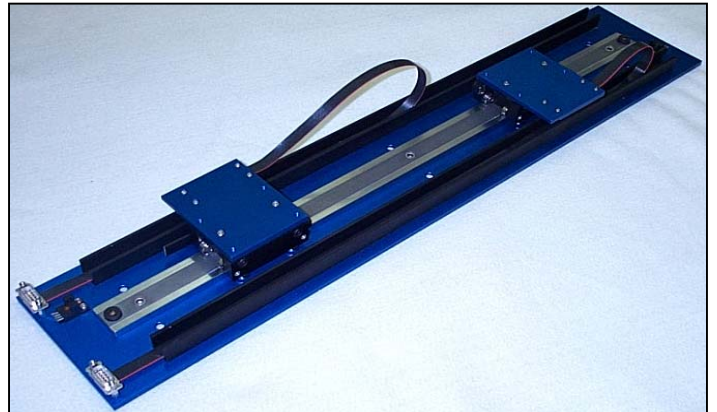

Dual Forcer

18" Stroke per motor
*Two motors on 1 platen
*Home switch for each motor

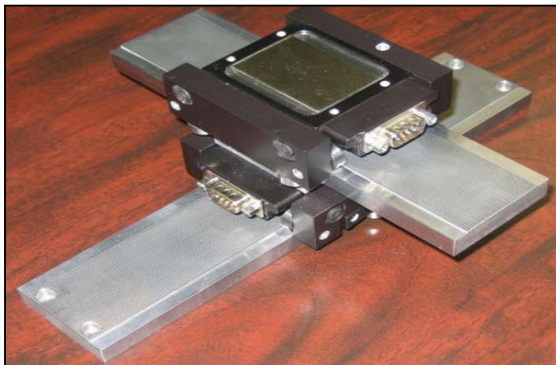

XY (Low Cost)

X-Axis = 6" Stroke
Y-Axis = 4" Stroke

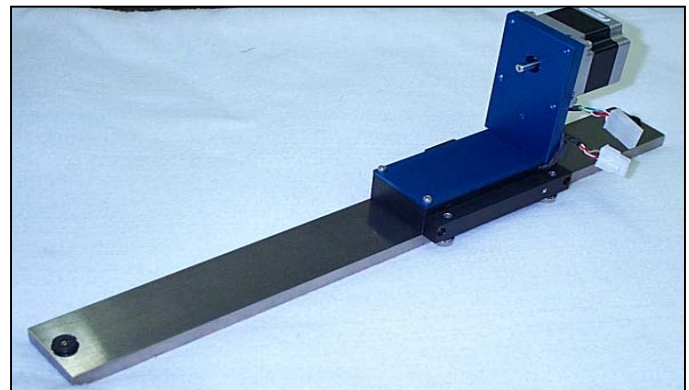

X-Theta / 2 Theta

14" stroke, 360° Rotary Stepper NEMA 17
*Air bearing stepper

3 PHASE BRUSHLESS LINEAR MOTOR

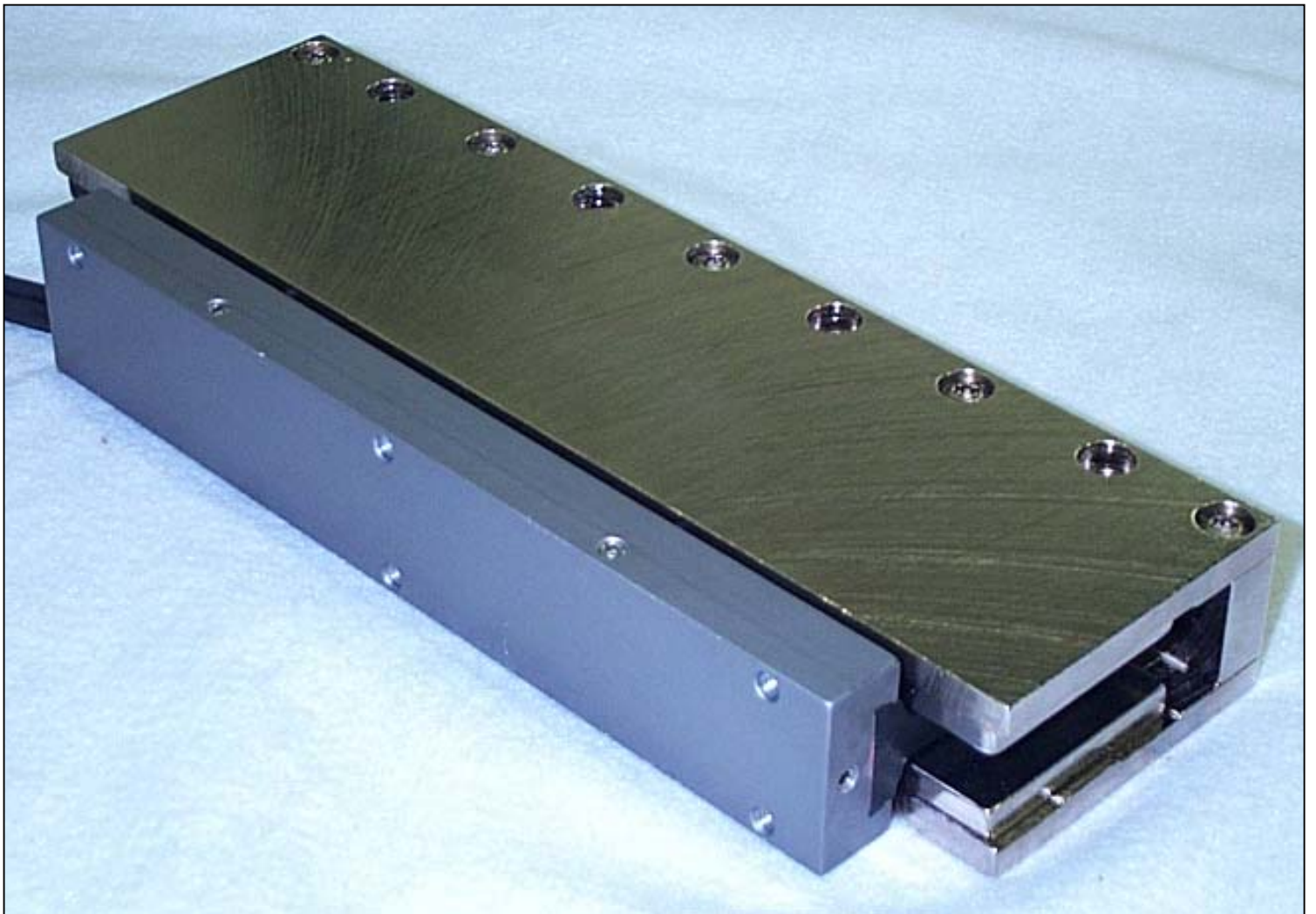

3 Phase Brushless Linear Motor

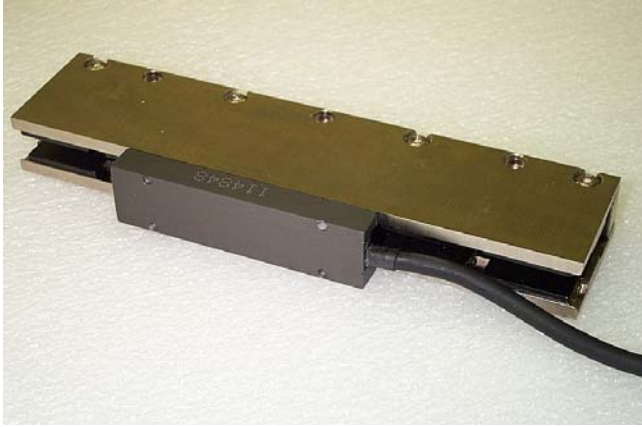

Travel	Unlimited	Unlimited
Velocity	240 inches / sec	[6 m/s]
Acceleration	12 G's	12 G's
Peak Force	600 lbs	[2669 N]
Continuous Force	200 lbs	[888 N]

The 3 phase brushless (or AC servo) linear motor is ideal for long stroke, closed loop servo, linear motion applications. They can be used at speeds up to 240 in / sec [6 m / sec]. They are capable of very precise position, velocity and acceleration control when coupled with a linear encoder.

The 3-phase coil assembly can be commutated trapezoidally using integral Hall Effects or sinusoidally using software commutation in conjunction with the appropriate motion controller and sinusoidal amplifier.

The short encapsulated moving coil assembly moves thru a gap in the long "U" shaped magnet assembly. A customer supplied bearing system is

required to guide the moving coil assembly and to maintain a .025" [0.63 mm] clearance between the magnet and the coil assembly.

The power to the motor (from a customer supplied PWM 3 phase brushless servo amplifier) is supplied to the moving secondary via a power cable.

Larger motors with higher forces are available, consult factory for details and drawings.

The motors are available in 3 different cross sections and 5 different coil assembly lengths.

Advantages:

- Zero cogging
- High speed and accelerations of light loads
- Low moving mass
- Uses standard 3 phase brushless amplifier

Applications:

- Pick and Place Machines
- Coordinate measuring machines
- Laser and Water jet cutters
- Vision Inspection Equipment

The Brushless Linear Motor consists of 2 main parts

- **Long Stationary Magnet Assembly:** The "U" shaped magnet assembly is made up of nickel-plated steel back iron and Neodymium permanent magnets. The magnets are bonded to the 2 parallel steel plates and the plates are bolted to a steel spacer bar. Threaded and thru holes are available in the steel back iron for mounting the magnet assembly to the customer supplied base plate. The magnet assembly is available in widths from 1.59" to 2.65" [40.4 mm to 67.3 mm]. The length of the magnet assembly is a function of the stroke. Single piece motors are available as long as 36 inches [0.91 m] for series BLSA & BLSB motors and 66 inches [1.67 m] for series BLSC motors. Longer motors will be supplied in modular sections.
- **Short Moving Coil Assembly:** The coil assembly is comprised of a 3 phase copper motor winding, an aluminum mounting bracket and an optional Hall Effect board that are all vacuum encapsulated with epoxy. Mounting holes in the aluminum bracket are provided for attaching the secondary to the moving member of the customer supplied table assembly. The coil assembly is available in many different widths and lengths, to meet the customers force and packaging requirements. Multiple coils can be supplied with a single magnet assembly to allow for independent moving heads or they can be coupled together to produce larger forces. The standard lengths for the coil assemblies are from 3.20" [81.3 mm] to 12.80" [325 mm].

Required Electronics:

The motor requires either a trapezoidal or sinusoidal 3 phase brushless amplifier with power supply that is rated with sufficient current and voltage to meet the motion requirements. The inductance of the linear motor coil should be greater than the minimum load inductance of the servo amplifier.

Environmental Considerations:

The brushless motor is an open type motor and should not be mounted in an environment that is wet or excessively dirty. It should be protected with some type of bellows or cover when installed by the customer.

Mounting:

The brushless linear motor should be mounted to flat (better than .003"/ft [246 microns / m] and stiff surface. Threaded and thru holes in the magnet assembly and threaded holes in the coil assembly are present for the mounting of the motor to the customers system. A cable carrier must be provided by the customer to route the motor and Hall Effect cable. The motor may be mounted in any orientation.

Ordering Info:

DC brushless motors can be ordered for any stroke and any DC peak force up to 240 lbs. Higher forces can be achieved by adding additional coil assemblies in series (consult factory for more information)

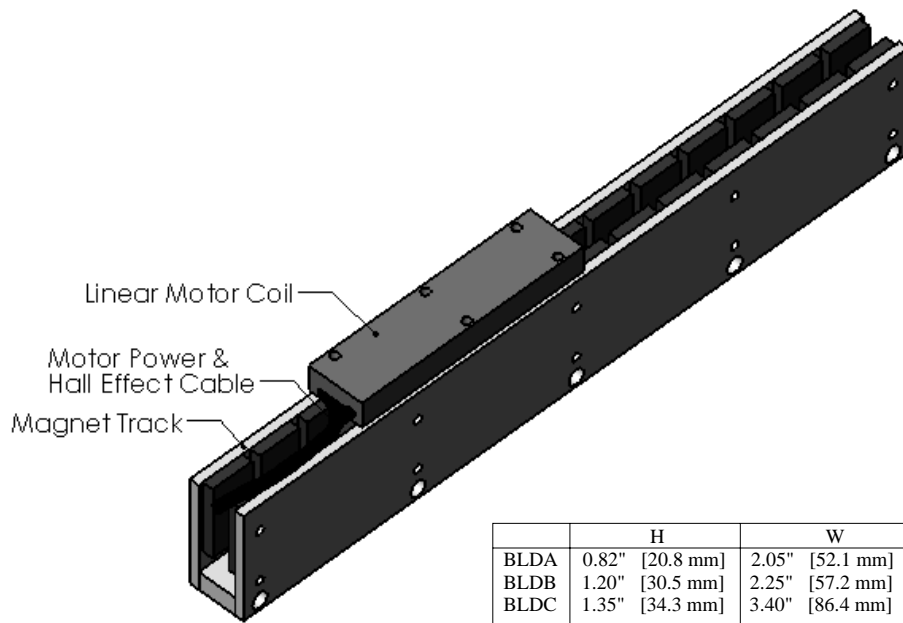

	H	W	A	B	C
BLDA	0.82" [20.8 mm]	2.05" [52.1 mm]	4-40 [M3]	6-32 [M3]	6-32 [M3]
BLDB	1.20" [30.5 mm]	2.25" [57.2 mm]	6-32 [M3]	8-32 [M4]	8-32 [M4]
BLDC	1.35" [34.3 mm]	3.40" [86.4 mm]	10-32 [M5]	10-32 [M5]	10-32 [M5]

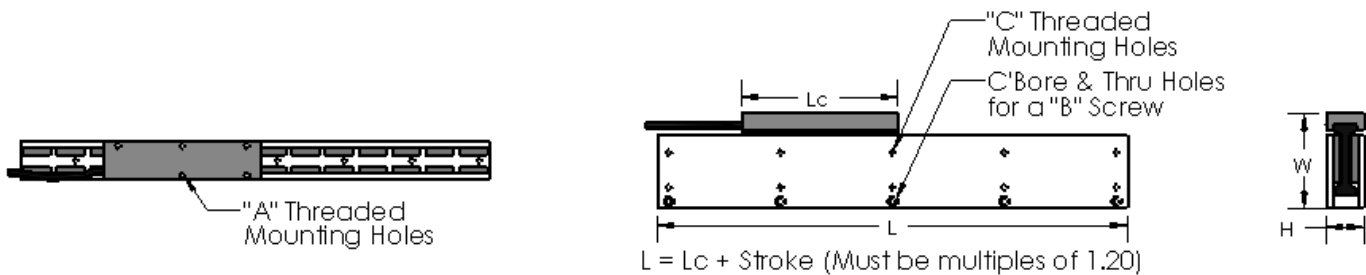

Model #	Kp lbs/amp [N/amp]		F cont lbs[N]		F peak lb [N]		I c amps	I p amps	Ve V/in/s V/m/s		Rc ohms	L mHenry	Lc In [mm]		Coil Weight lbs [Kg]
BLDA-01	1.5	[6.8]	5.5	[24.5]	16.5	[73.5]	3.6	10.8	0.20	[7.90]	3.8	1	3.2	[81.3]	0.27 [0.12]
BLDA-02	3.1	[13.7]	10	[45]	45	[202]	3.1	9.3	0.40	[15.7]	7.6	2	5.6	[142.2]	0.48 [0.22]
BLDB-02	4.9	[21.8]	14	[62.2]	38.7	[172]	2.6	7.8	0.64	[25.2]	11.8	4.8	5.6	[142.2]	0.6 [0.27]
BLDB-03	7.4	[32.7]	19	[84.5]	56.7	[252]	2.6	7.8	0.96	[37.8]	17.7	7.2	8.0	[203.2]	0.86 [0.39]
BLDC-02	6.1	[27.3]	20	[89]	60	[267]	3.4	10.2	0.80	[31.5]	8.6	6	5.6	[142.2]	1.22 [0.55]
BLDC-03	9.2	[40.9]	30	[134]	90	[402]	23.3	9.9	1.2	[47.2]	12.9	9	8.0	[203.2]	1.75 [0.79]
BLDC-04	12.3	[54.7]	40	[178]	120	[534]	3.2	9.6	1.6	[63]	17.2	12	10.4	[264.2]	2.27 [1.03]
BLDC-05	15.3	[68.1]	50	[222]	150	[667]	3.2	9.6	2.0	[78.7]	21.5	15	12.8	[325.1]	2.8 [1.27]
BLDC-06	18.4	[81.8]	60	[267]	180	[800]	3.2	9.6	2.4	[94.5]	25.8	18	15.2	[386.1]	3.36 [1.53]
BLDD-03	18.4	[81.8]	75	[333]	225	[1000]	4.2	12.6	2.4	[94.5]	12.0	15	11.2	[285]	5.0 [2.27]
BLDD-04	24.5	[109]	100	[444]	300	[1334]	4.1	12.3	3.2	[126]	16.0	20	14.6	[369]	6.5 [2.95]
BLDD-05	36.8	[163.7]	150	[667]	450	[2000]	4.1	12.3	4.8	[189]	24.0	30	21.3	[541]	9.5 [4.32]
BLDD-06	49.1	[218.4]	200	[888]	600	[2669]	4.0	12.0	6.4	[252]	32.0	40	28.0	[711]	12.5 [5.68]

F cont = Continuous Force, F peak = Peak Force @ 10% Duty

Kp = Force Constant, I c = Continuous Current, I p = Peak Current @ 10 % Duty

Required DC Bus Voltage for Amplifier; $V_{required} = (I_{peak} \times R_c \times 1.4) + (\text{Back EMF} \times \text{Velocity})$

3 Phase Brushless Linear Motor

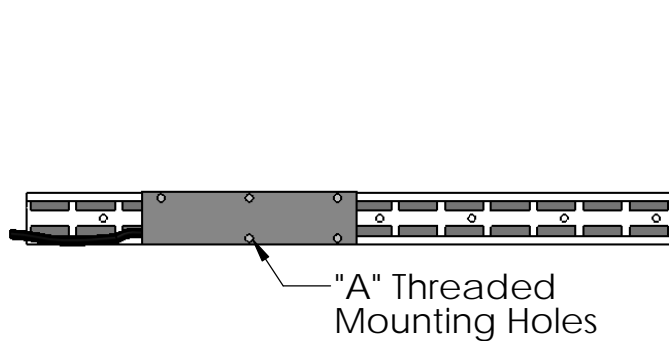
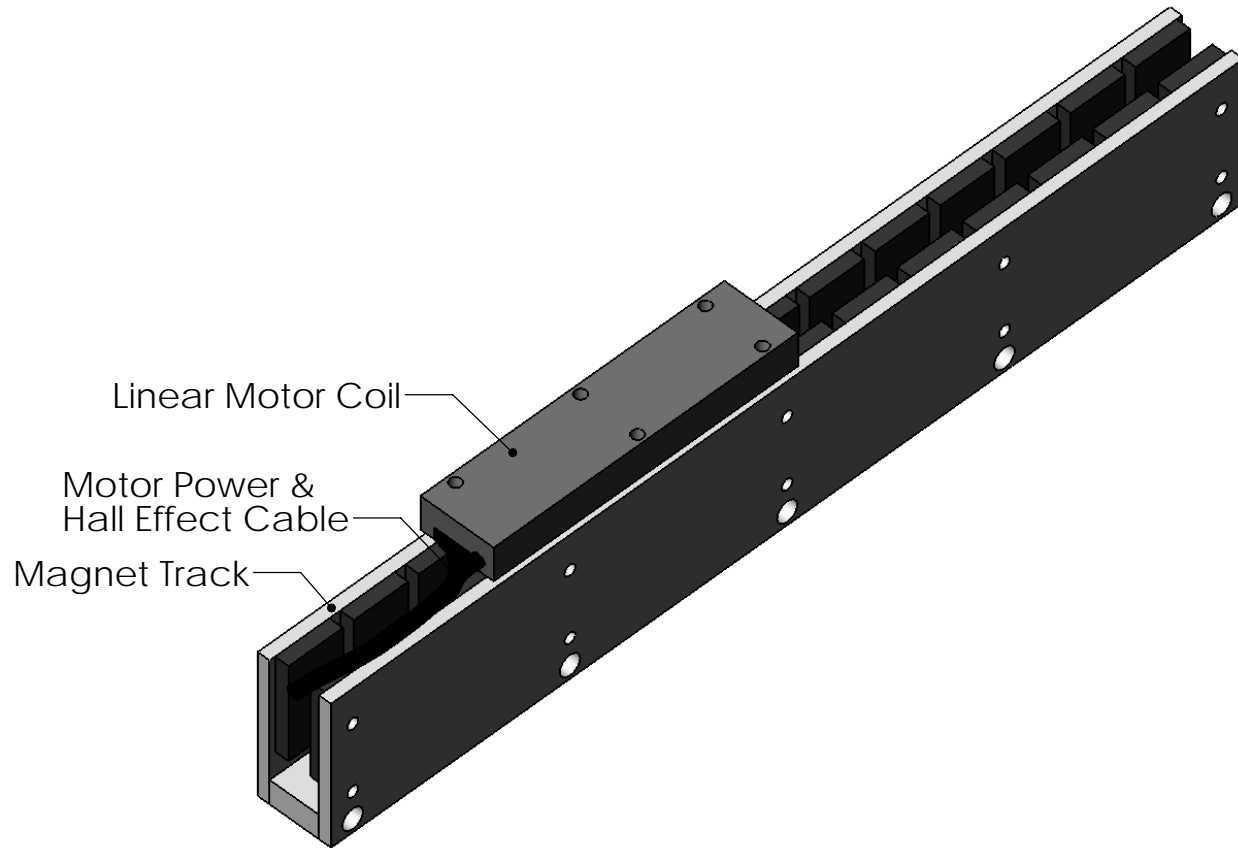

TOP

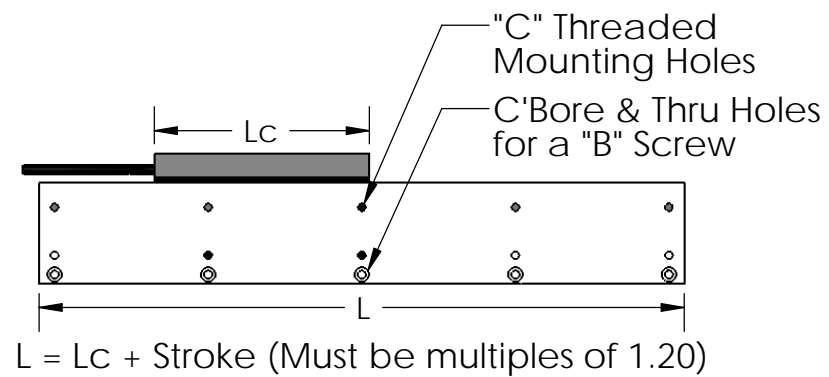

SIDE

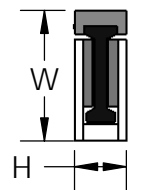

FRONT

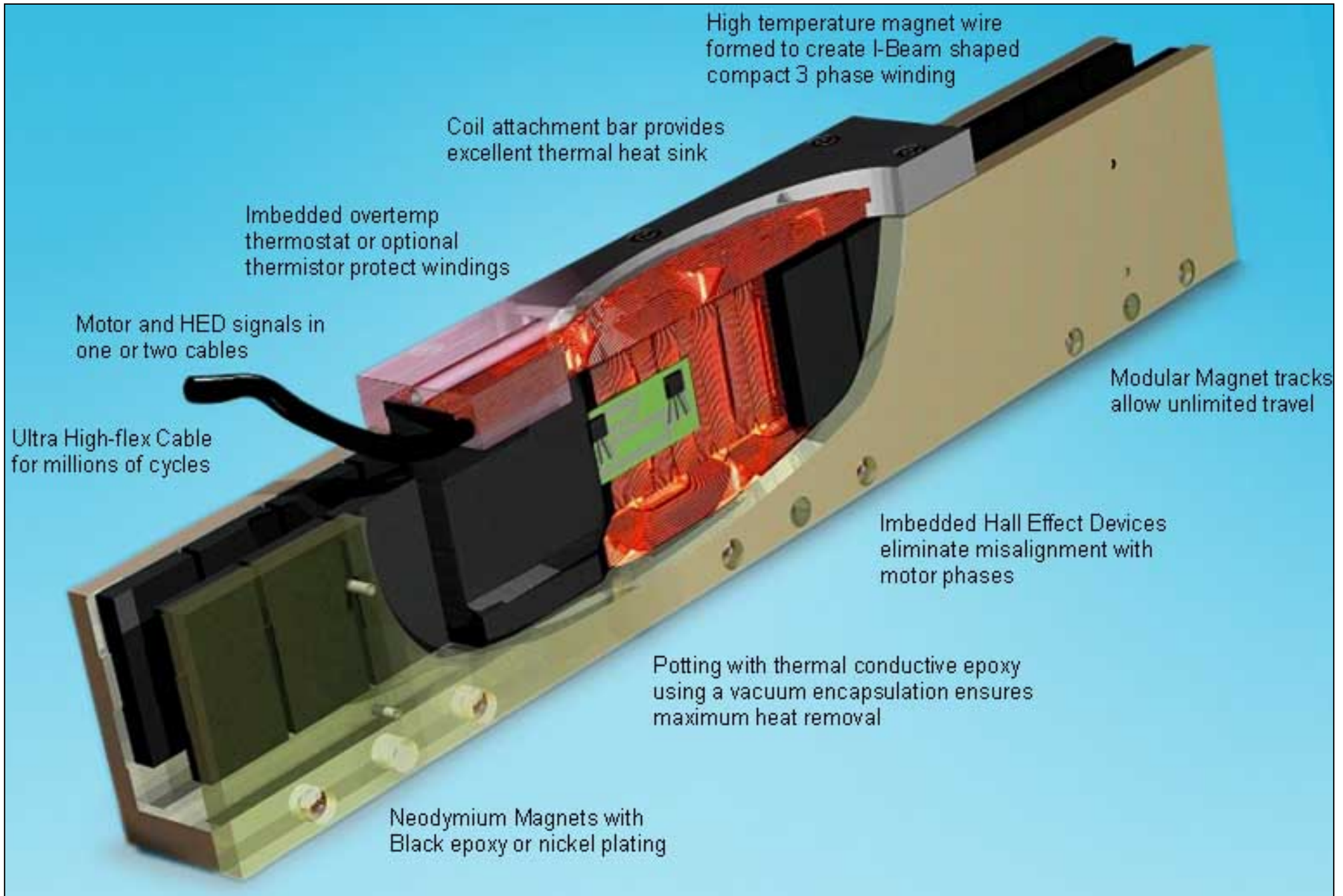

High temperature magnet wire formed to create I-Beam shaped compact 3 phase winding

Coil attachment bar provides excellent thermal heat sink

Imbedded overtemp thermostat or optional thermistor protect windings

Motor and HED signals in one or two cables

Ultra High-flex Cable for millions of cycles

Modular Magnet tracks allow unlimited travel

Imbedded Hall Effect Devices eliminate misalignment with motor phases

Potting with thermal conductive epoxy using a vacuum encapsulation ensures maximum heat removal

Neodymium Magnets with Black epoxy or nickel plating

DC LINEAR BRUSH MOTOR



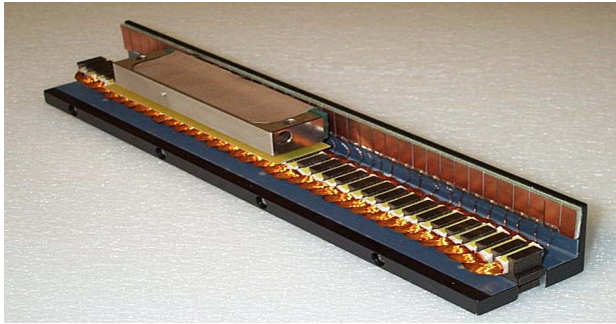

Travel	120 inches	[3 m]
Velocity	100 inches / sec	[2.5 m/s]
Acceleration	12 G's	12 G's
Peak Force	180 lbs	[800 N]
Continuous Force	60 lbs	[266 N]

The DC brush linear motor is ideal for long stroke, open or closed loop servo, linear motion applications. They can be used at speeds up to 100 in / sec [2.5 m / sec] and as low as 1 in/sec [25 mm / sec]. They are capable of very precise position, velocity and acceleration control when coupled with a linear encoder.

The motor is commutated using brushes on the moving permanent magnet secondary in conjunction with a stationary commutator bar on the coil assembly. This results in only the coils directly beneath the secondary with current flowing in them.

The short moving brush assembly is magnetically attracted to the long stationary laminated coil assembly. A customer supplied bearing system is required to guide the moving secondary and to maintain a .025" [0.63 mm]

gap between the secondary and the coil assembly.

The power to the motor (from a customer supplied PWM DC servo amplifier) is supplied to the moving secondary via a power cable. The resultant force is proportional to the input current.

The low overall height (1.65" [41.9 mm]) of the brush motor allows it to fit into a very compact space. The low moving mass of the secondary allows for higher accelerations of light payloads.

The motor comes in different widths and secondary lengths to meet different force and packaging requirements.

Advantages:

- Low profile and small cross section
- Available in many different widths and lengths
- High Acceleration of light loads
- High Speed
- Uses low cost PWM amplifier

Applications:

- Pick and Place
- Coordinate measuring machines
- Parts transfer
- Inspection Machines

The Linear Brush Motor consists of 2 main parts

- **Long Stationary Coil Assembly:** The laminated motor stacks are insulated and bonded together. The copper coils are inserted into insulated slots in the stack. The ends of the coils are brought out and soldered to the commutator bar. An aluminum mounting angle and a mounting bar are bolted to each side of the lamination stack. Threaded mounting holes in the angle or "T" nuts are available to mount the coil assembly to the customer supplied base plate. The coil assembly is available in widths from 2.0" to 5.0" [50 mm to 125 mm]. The length of the coil assembly is a function of the stroke. Single piece motors are available as long as 144 inches [3.6 m]. Longer motors will be made in sections.
- **Short Moving Secondary Assembly:** The secondary is made of nickel plated steel with permanent magnets bonded to bottom. A PCB with brushholders and brushes soldered on, is mechanically attached to the side of the secondary. Mounting holes are provided for attaching the secondary to the moving member of the customer supplied table assembly. The secondary comes in different widths and lengths, depending on the required force. Multiple secondaries can be supplied with a single coil assembly to allow for independent moving heads or they can be coupled together to produce larger forces. The standard lengths for the secondaries are 4.38" for BRA motors and 9.56" for BRB motors.

Required Electronics:

The motor requires a single phase brush type PWM amplifier with power supply, that is rated with sufficient current and voltage to meet the motion requirements. The inductance of the linear motor coil should be greater than the minimum load inductance of the servo amplifier.

Environmental Considerations:

The brush motor is an open type motor and should not be mounted in an environment that is wet or excessively dirty. It should be protected with some type of bellows or cover when installed by the customer.

Mounting:

The DC brush motor should be mounted to flat (better than .003"/ft [246 microns / m] and stiff surface. Threaded holes on the bottom of the coil assembly or optional thru holes are present in the aluminum angles to allow for the mounting of the motor to the customers system. The moving secondary assembly has threaded holes on the top surface for attaching it to the customer supplied moving table. The motor may be mounted in any orientation. When mounting the

stage with the secondary moving vertical, it should be noted that the stage will be required to generate additional force due to gravity and that the stage will slide down to the bottom when power fails.

Ordering Info:

DC brush motors can be ordered for any stroke up to 144inches and any peak force up to 180 lbs. Higher forces can be achieved by adding additional secondaries in series (consult factory for more information)

Model Number	Width (W)		F cont		F peak		Force Constant		Back EMF		R	L	Magnetic Attraction	
	(in)	[mm]	(lbs)	[N]	(lbs)	[N]	lbs/amp	[N/amp]	(V/in/sec)	[V/m/sec]	(ohms)	(mH)	(lbs)	[N]
BRA-XXX-051	2.0	[51]	4	[19]	13	[58]	0.9	[4]	0.1	[3.9]	1	1.2	45	[200]
BRA-XXX-064	2.5	[64]	9	[38]	26	[116]	1.7	[8]	0.19	[7.9]	1.4	2.4	90	[400]
BRA-XXX-076	3.0	[76]	13	[58]	40	[178]	2.6	[12]	0.29	[11.5]	1.7	3.5	135	[600]
BRA-XXX-084	3.3	[76]	15	[67]	47	[209]	3.0	[13]	0.34	[13.2]	1.9	4.1	160	[710]
BRA-XXX-089	3.5	[84]	17	[75]	54	[240]	3.5	[16]	0.39	[15.4]	2.1	4.7	180	[800]
BRA-XXX-102	4.0	[102]	22	[98]	68	[302]	4.3	[19]	0.48	[19.0]	2.4	5.9	225	[1000]
BRA-XXX-114	4.5	[114]	26	[115]	82	[364]	5.2	[23]	0.58	[22.9]	2.7	7.1	270	[1200]
BRA-XXX-127	5.0	[127]	31	[138]	96	[427]	6.1	[27]	0.68	[26.9]	3.1	8.2	315	[1400]

Model Number	Width (W)		Fc		Fp		Force Constant		Back EMF		R	L	Magnetic Attraction	
	(in)	[mm]	(lbs)	[N]	(lbs)	[N]	lbs/amp	[N/amp]	(V/in/sec)	[V/m/sec]	(ohms)	(mH)	(lbs)	[N]
BRB-XXX-051	2.0	[51]	8	[36]	25	[111]	0.9	[4]	0.1	[3.9]	0.5	0.6	90	[400]
BRB-XXX-064	2.5	[64]	17	[76]	52	[231]	1.7	[8]	0.19	[7.9]	0.7	1.2	180	[800]
BRB-XXX-076	3.0	[76]	25	[111]	78	[347]	2.6	[12]	0.29	[11.5]	0.9	1.8	270	[1200]
BRB-XXX-084	3.3	[84]	29	[129]	91	[404]	3.0	[13]	0.34	[13.2]	0.9	2.1	315	[1400]
BRB-XXX-089	3.5	[89]	34	[151]	104	[462]	3.5	[16]	0.39	[15.4]	1	2.4	360	[1600]
BRB-XXX-102	4.0	[102]	42	[187]	131	[582]	4.3	[19]	0.48	[19.0]	1.2	2.9	450	[2000]
BRB-XXX-114	4.5	[114]	51	[227]	157	[698]	5.2	[23]	0.58	[22.9]	1.4	3.5	540	[2400]
BRB-XXX-127	5.0	[127]	69	[267]	185	[822]	6.1	[27]	0.68	[26.9]	1.5	4.1	600	[2670]

F cont = Continuous Force, F peak = Peak Force @ 10% Duty
 For BRA motors; I continuous = 5.0 Amps, I peak = 15.0 Amps
 For BRB motors; I continuous = 10.0 Amps, I peak = 30.0 Amps
 Required DC Bus Voltage for Amplifier; $V_{required} = (I_{peak} \times R_c \times 1.4) + (\text{Back EMF} \times \text{Velocity})$
 The -XXX in the model number is for the stroke in inches (i.e. 18 inches is -018)
 Ls = 4.38 [111.3 mm] for BRA motors and Ls = 9.56" [242.8 mm] for BRB motors

Brush Motor (U Shape)

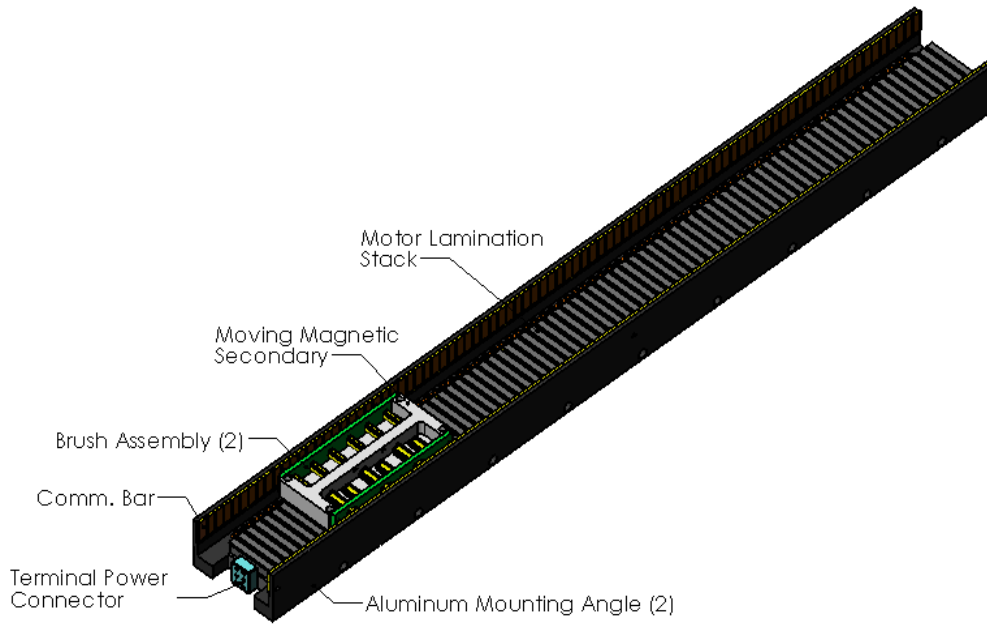

Brush Motor (L Shape)

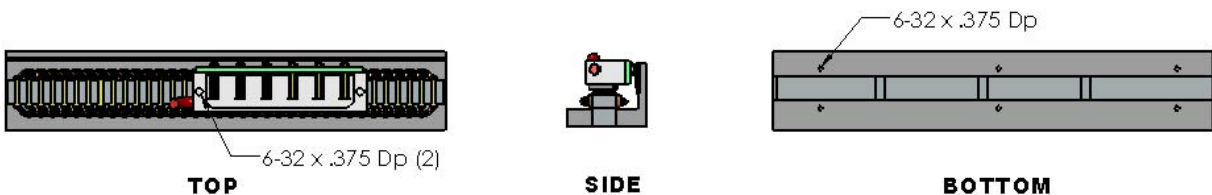
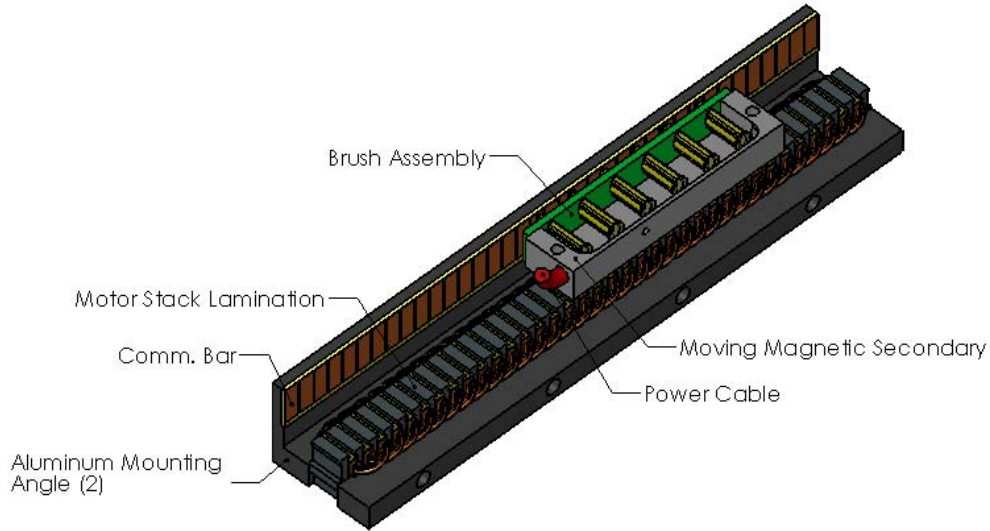

Brush Motor (L Shape)

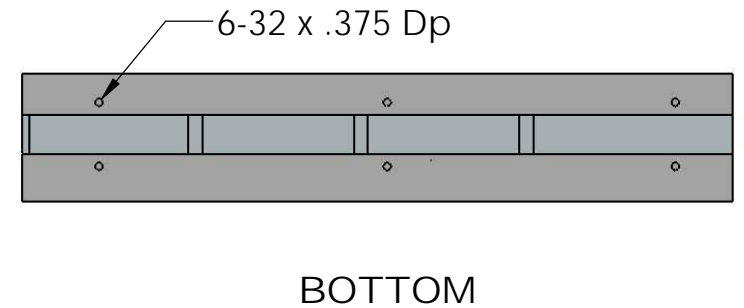
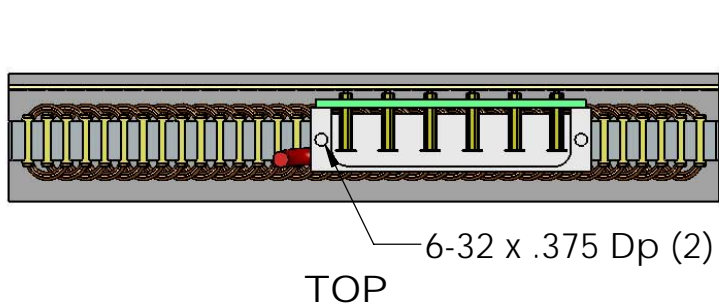
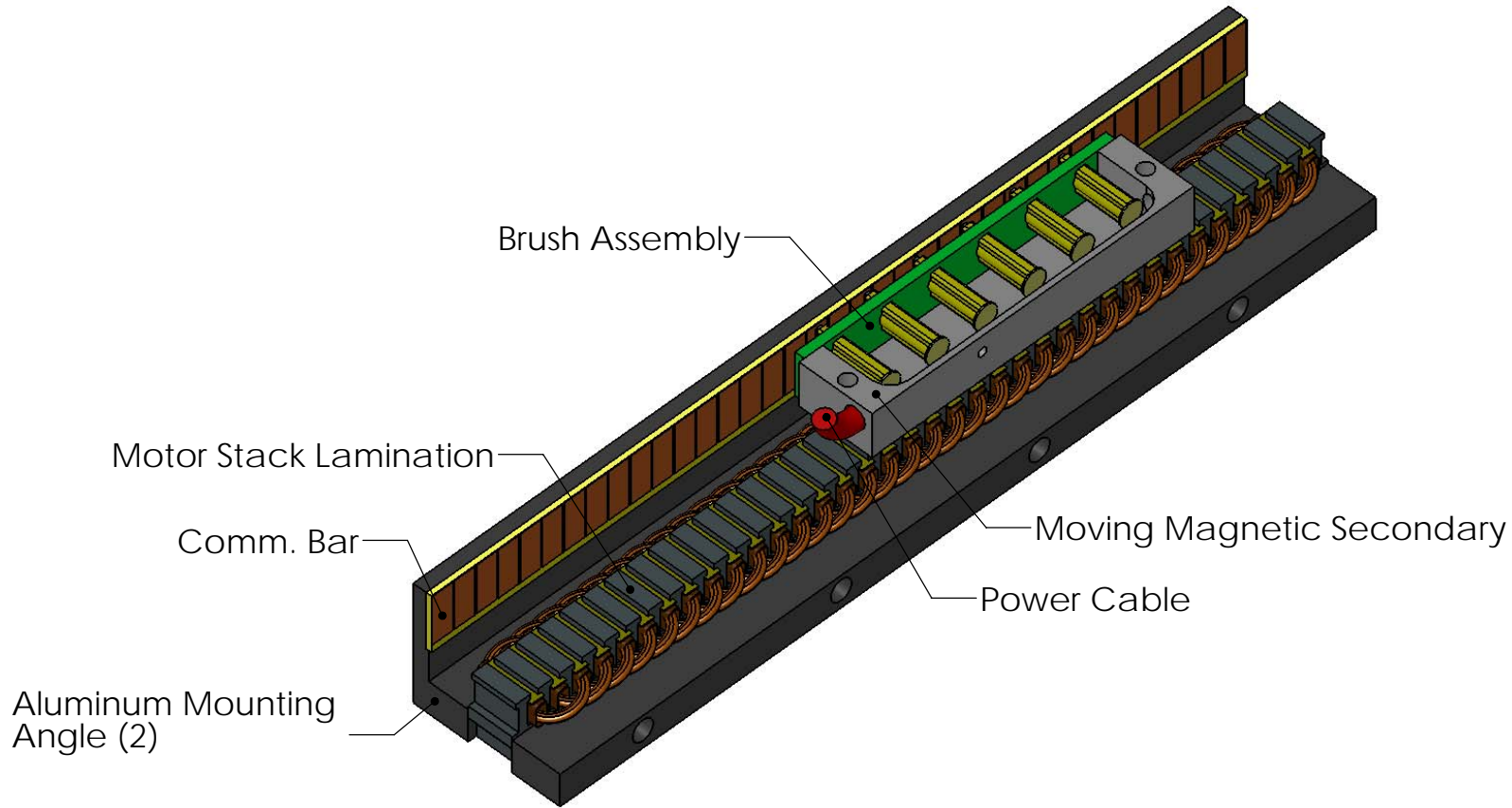

Brush Motor (U Shape)

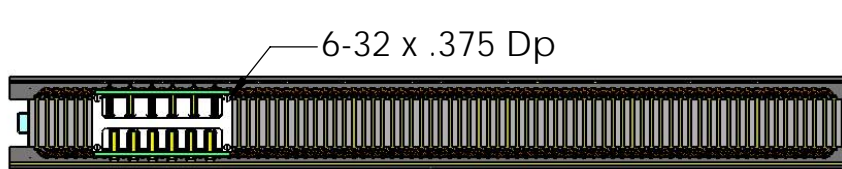
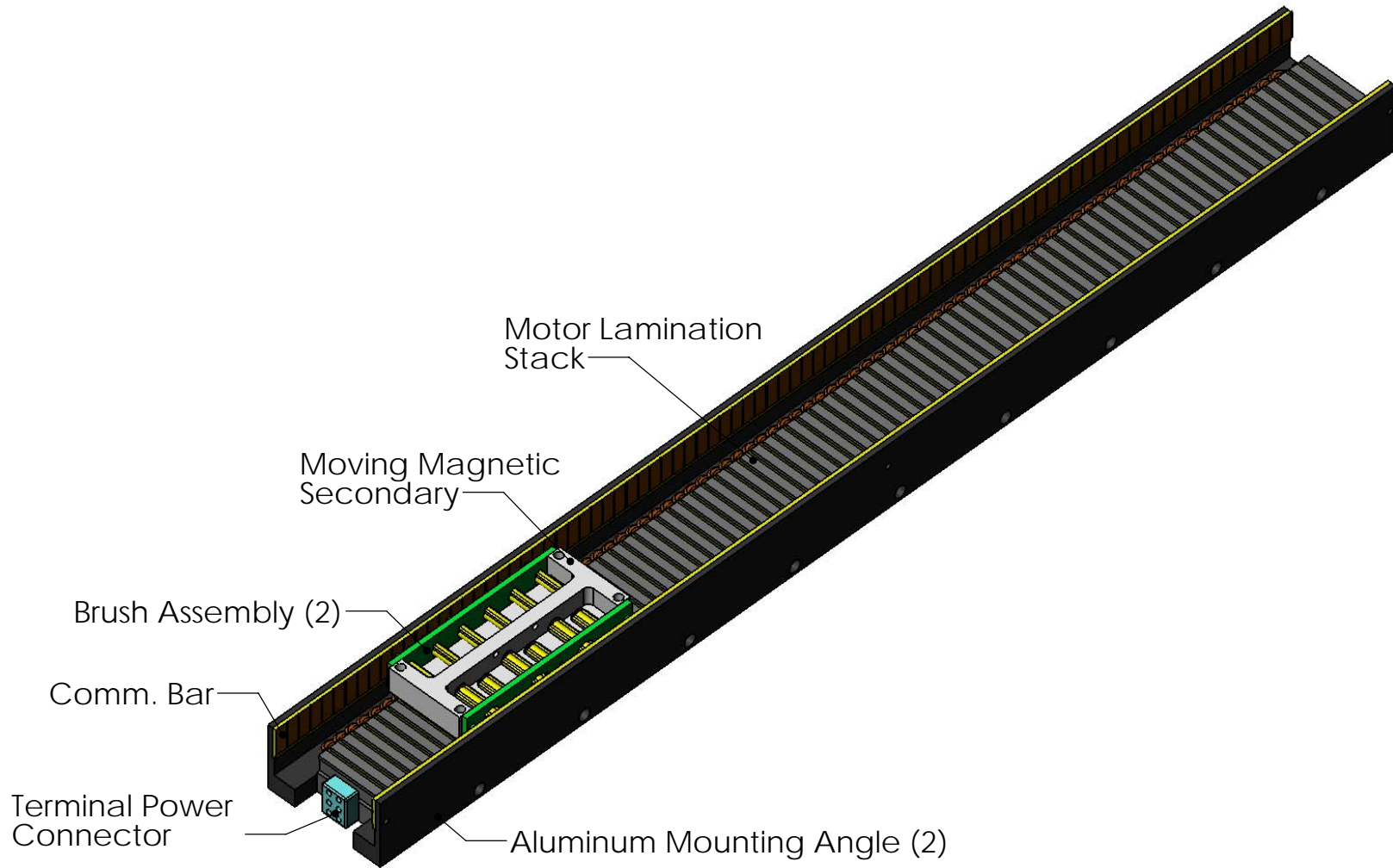

TOP

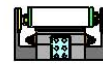

FRONT

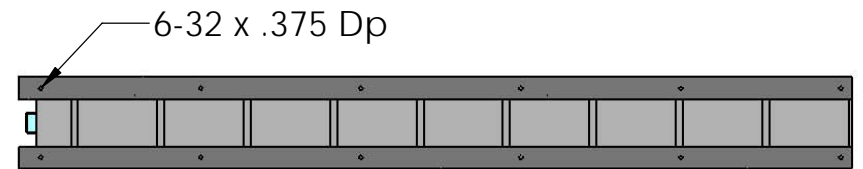

BOTTOM

DC LINEAR BRUSH MOTORS

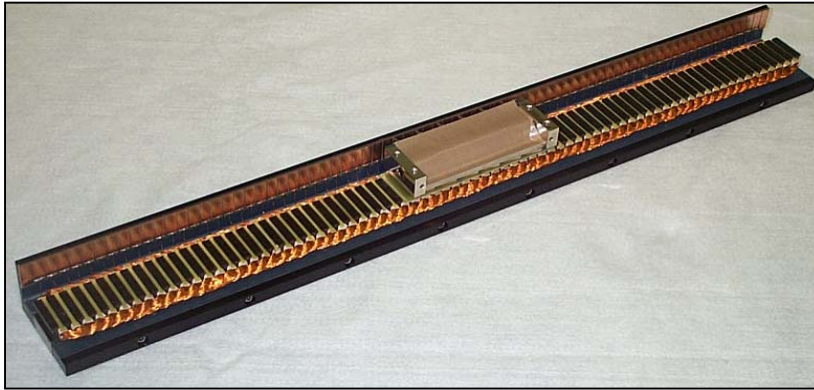

BRA018-060438 Lx
8.5 lbs cont.
25.5" peak
5amp cont.
15 amp peak
18 " travel

BRA006-051019 Lx
4.2 lbs cont.
12.6 lbs peak
4.8 amps cont.
14.4 amps peak
6" travel

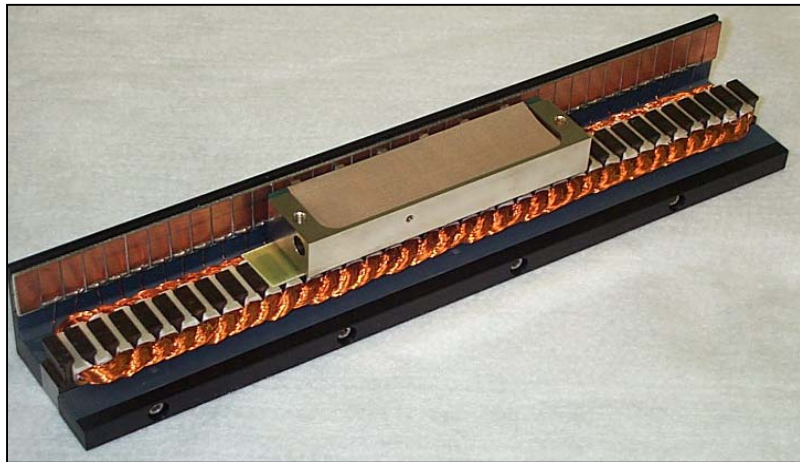

BRA010-076058 Ux

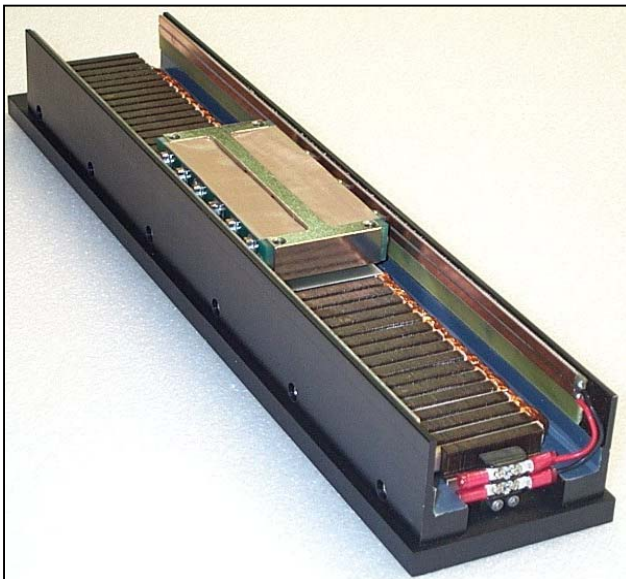

BRA018-076058 Lx

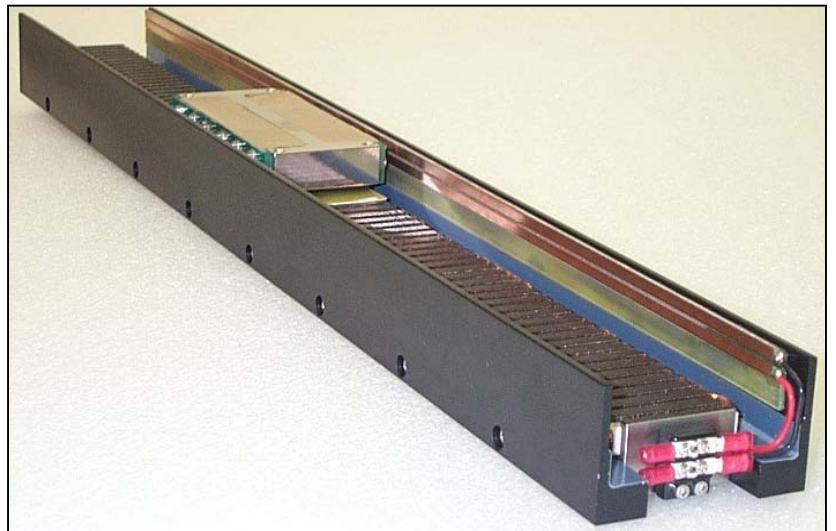

13 lbs cont, 39 lbs peak
5 amps cont., 15 amps peak
10" travel

VOICE COIL LINEAR ACTUATORS





Travel	2 inches	[50 mm]
Acceleration	20 G's	20 G's
Peak Force	300 lbs	[1333 N]
Continuous Force	100 lbs	[444 N]
Resolution	.00004" or .0002"	[1 or 5 micron]

H2W Technologies [Non commutated DC Linear \(NC\) Actuators](#) are ideal for short stroke (typically less than 2 inches) closed loop servo applications. Their compact size allows them to fit into small spaces. They have very low electrical and mechanical time constants. The low moving mass allows for high accelerations of light payloads.

These actuators are wound in such a way that no commutation is required for motion to occur (hence the name non commutated). The result is a much simpler and more reliable system.

Coupling the actuators with a bearing system (if not supplied), position feedback device, linear servo amplifier and motion controller yields a system that is capable of intricate position, velocity, and acceleration control. These actuators can also be used for precise force control because of the linear force versus current characteristics.

NC Actuators operate on the principal of the [Lorentz Force Equation](#)

$$\text{Force} = B \times I \quad \text{where: } B = \text{Flux density (Tesla)}$$

$$I = \text{Current (Amps)}$$

Simply stated, a current carrying conductor placed in a magnetic field will have a force exerted upon it. This force is proportional to the direction and magnitude of the current and the flux density field. Since the permanent magnet flux density field is fixed, the direction of the linear displacement depends on the polarity of input current. The amount of force that is produced is directly proportional to the magnitude of the input current.

They are available in both standard as well as custom sizes. You can choose from either the moving magnet ([NCM type](#)) or moving coil type ([NCC Type](#)),

- The moving coil actuators, [NCC Type](#) (sometimes referred to as voice coils) are typically supplied without bearings or a shaft, but can be added if desired. They are generally larger in diameter and shorter in length. Higher forces can be achieved by increasing the diameter. This type of actuator can be designed with large radial clearances to ensure no contact between the coil and magnet assembly if a tilt or radial movement is required.
- The moving magnet actuators, [NCM Type](#) are supplied with bearings and a shaft. This type is generally smaller in diameter and longer in length. Higher forces can be achieved by increasing the number of poles, which increases the length, or by increasing the diameter. The main advantage is that there are no moving leads since the coil assembly is stationary. Optional no power magnetic latching is available at one or both ends of the stroke.

It should be noted that for both types of actuators, longer strokes are available but the efficiency or motor constant (Km) decreases as the stroke increases. This is due to the fact that the motor constant is inversely proportional to the stroke. If higher efficiency is desired for longer stroke actuators, the coil assembly can be wound as a multiphase coil and then it will have to be commutated.

Advantages:

- Small Size, High Force to Weight Ratio
- High Accelerations
- No Cogging or Commutation
- Custom Designs with Quick Turnaround Times
- High Flux Density Neodymium Magnets are Used

Applications:

- Z Axis for Pick and Place Equipment
- Medical Diagnostic Probes and Laser Beam Steering
- Hermetically Sealed Cryo Cooler Actuators
- Mirror Tilt and Focusing Actuators
- Miniature Position Control

Required Electronics:

Because of the very low inductance of the actuator, a DC linear servo amplifier is required to provide power to the [NC Actuator](#). A programmable motion controller is required to close the position loop on the system.

Environmental Considerations:

The NC Actuators should not be mounted in an environment that is wet or excessively dirty or in an environment with ambient temperatures (>50°C).

Mounting:

Mounting holes are provided on the housing, shaft and / or coil assemblies for mounting the actuator to customer supplied base and payload

Maintenance:

No maintenance is required.

Ordering Info:

NC Actuators are available in many different standard and custom sizes, strokes and configurations. Custom actuators can be delivered in 4 to 5 weeks. Standard units are available from stock and can be shipped within 48 hours.

Model # NCABB – CC – DDD – EX

where: A is C for moving coil or M for moving magnet
BB is the stroke (05 is 0.5 inch)

CC is the outside housing diameter (15 is 1.5 inch)

DDD is continuous force in lbs (140 is 14.0 lbs)

E is the number of poles

X is for special options

(I.e. NCC05-15-020-2X is a moving coil actuator with 0.5" stroke, 1.5" OD, 2.0 lbs of continuous force, 2 pole magnet assembly and no special options)

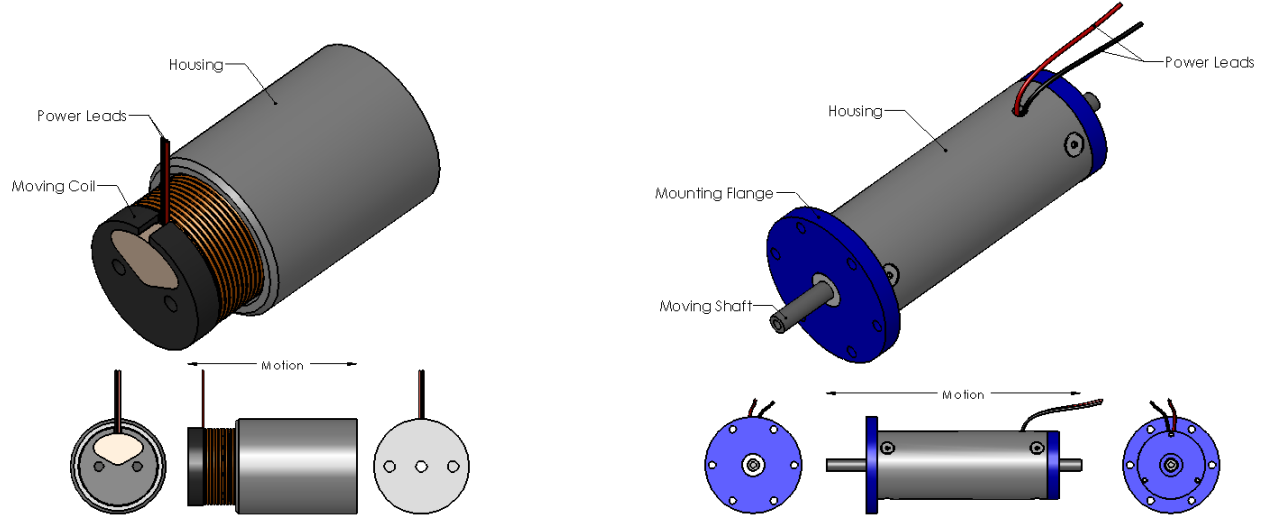

Model #	Stroke	Continuous Force	Peak Force	Km lbs/(watt) ^{.5}	Outside Diameter (D)	Housing Length (L)
				[N/(watt) ^{.5}]		
NCC01-04-001-1X	0.05" [1.3 mm]	0.06 lbs [0.3 N]	0.18 lbs [0.9 N]	0.08 [0.35]	0.438" [9.5 mm]	0.36" [9.1 mm]
NCC03-14-010-1SL	0.28" [7.1 mm]	0.8 lbs [3.6 N]	2.40 lbs [10.7 N]	0.35 [1.56]	1.45" [36.8 mm]	1.65" [41.9 mm]
NCC03-15-050-2X	0.25" [6.4 mm]	5.00 lbs [22 N]	15.0 lbs [66 N]	1.38 [6.01]	1.50" [38.1 mm]	1.50" [38.1 mm]
NCC04-10-005-1X	0.41" [10.4 mm]	0.50 lbs [2.2 N]	1.50 lbs [6.6 N]	0.37 [1.65]	0.98" [25 mm]	0.85" [21.5 mm]
NCC05-11-011-1X	0.50" [12.7 mm]	1.10 lbs [4.9 N]	3.30 lbs [14.7N]	0.67 [2.95]	1.20" [30.5 mm]	1.10" [27.9 mm]
NCC05-18-060-2X	0.50" [12.7 mm]	6.0 lbs [26.4 N]	18.0 lbs [79.2 N]	1.78 [7.83]	1.80" [45.7 mm]	1.95" [50 mm]
NCC06-08-005-2X	0.60" [15.2 mm]	0.50 lbs [2.2 N]	1.50 lbs [6.6 N]	0.37 [1.65]	0.81" [20.6 mm]	1.65" [41.9 mm]
NCC10-15-023-1X	1.00" [25.4 mm]	2.25 lbs [10 N]	6.75 lbs [30 N]	0.81 [3.56]	1.50" [38.1 mm]	1.91" [49 mm]
NCC20-18-020-1X	2.00" [50.8 mm]	2.00 lbs [8.9 N]	6.00 lbs [26.7 N]	0.86 [3.78]	1.50" [38.1 mm]	2.75" [70 mm]
NCC52-20-020-1X	5.20" [132.1 mm]	2.00 lbs [8.9 N]	6.00 lbs [26.7 N]	0.30 [1.32]	2.00" [50.4 mm]	5.90" [150 mm]

Model #	Stroke	Continuous Force	Peak Force	Km lbs/(watt) ^{.5}	Outside Diameter (D)	Housing Length (L)
				[N/(watt) ^{.5}]		
NCM02-05-005-4JB	0.15" [3.8 mm]	0.50 lbs [2.2 N]	1.50 lbs [6.6 N]	0.32 [1.41]	0.52" [13.2 mm]	1.67" [42.4 mm]
NCM03-06-005-5JB	0.26" [6.6 mm]	0.50 lbs [2.2 N]	1.50 lbs [6.6 N]	0.38 [1.67]	0.65" [16.5 mm]	3.57" [90.6 mm]
NCM04-25-250-2LVE	0.40" [12.7 mm]	25.0 lbs [80 N]	75.0 lbs [240.3 N]	2.88 [13.1]	3.49" [88.6 mm]	10.21" [259 mm]
NCM05-28-180-2X	0.50" [12.7 mm]	18.0 lbs [80 N]	54.0 lbs [240.3 N]	2.95 [13.1]	2.98" [75.7 mm]	4.75" [121 mm]
NCM05-08-005-2JB	0.50" [12.7 mm]	0.5 lbs [2.2 N]	1.5 lbs [6.6 N]	0.30 [1.32]	0.98" [25 mm]	2.74" [69.5 mm]
NCM05-23-100-3LB	0.50" [12.7 mm]	10.0 lbs [44.5 N]	30.0 lbs [133.4 N]	2.08 [9.22]	2.25" [57.1 mm]	4.76" [121 mm]
NCM06-06-004-3JB	0.60" [15.2 mm]	0.40 lbs [1.75 N]	1.20 lbs [5.25 N]	0.15 [0.66]	0.65" [16.5 mm]	2.77" [70.5 mm]
NCM10-15-020-2LB	1.00" [25.4 mm]	2.00 lbs [8.9 N]	6.00 lbs [26.4 N]	1.05 [4.62]	1.50" [38.1 mm]	4.25" [108.0 mm]
NCM15-15-032-2LB	1.50" [38.1 mm]	3.20 lbs [15 N]	9.60 lbs [42.7 N]	0.80 [3.52]	1.50" [38.1 mm]	5.50" [140 mm]
NCM30-25-090-2X	3.00" [76.2 mm]	9.0 lbs [40.1 N]	27.0 lbs [120 N]	1.16 [5.16]	2.50" [63.5 mm]	7.70" [195.6 mm]

*The peak force (@10% Duty) is equal to 3 times the continuous force.

Note: This is a partial listing; other sizes, forces and strokes are available. NCM and NCC Actuators can be custom designed to meet your specifications. Consult H2W for more information

NCC (Moving Coil)

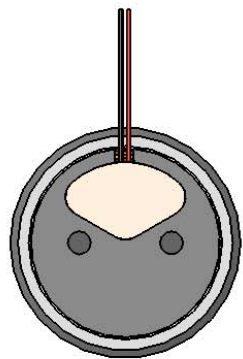
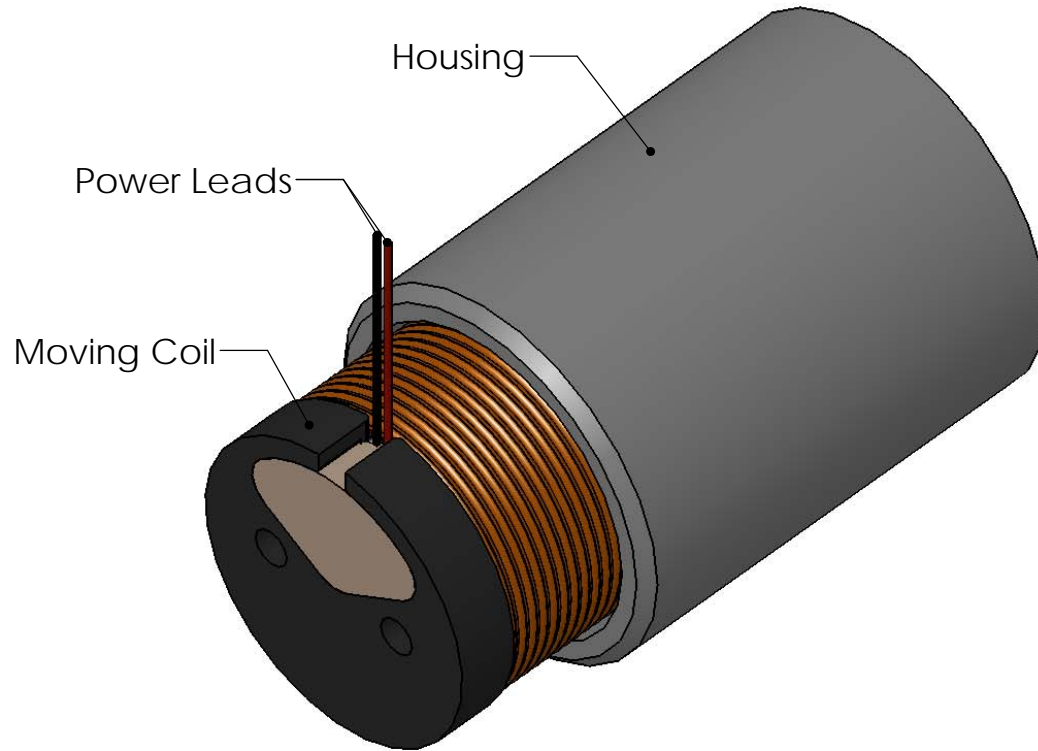

TOP

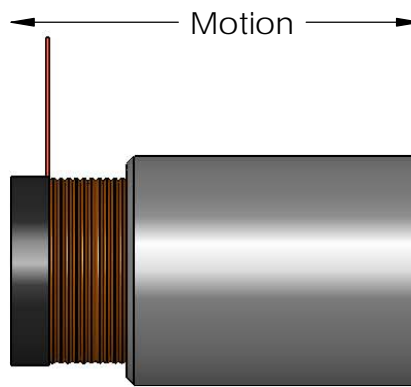

SIDE

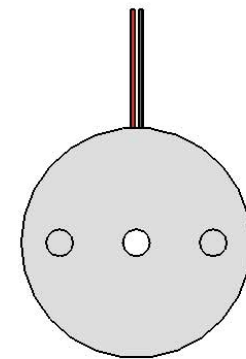

BOTTOM

NCM (Moving Magnet)

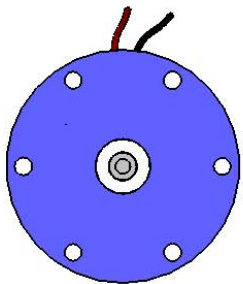
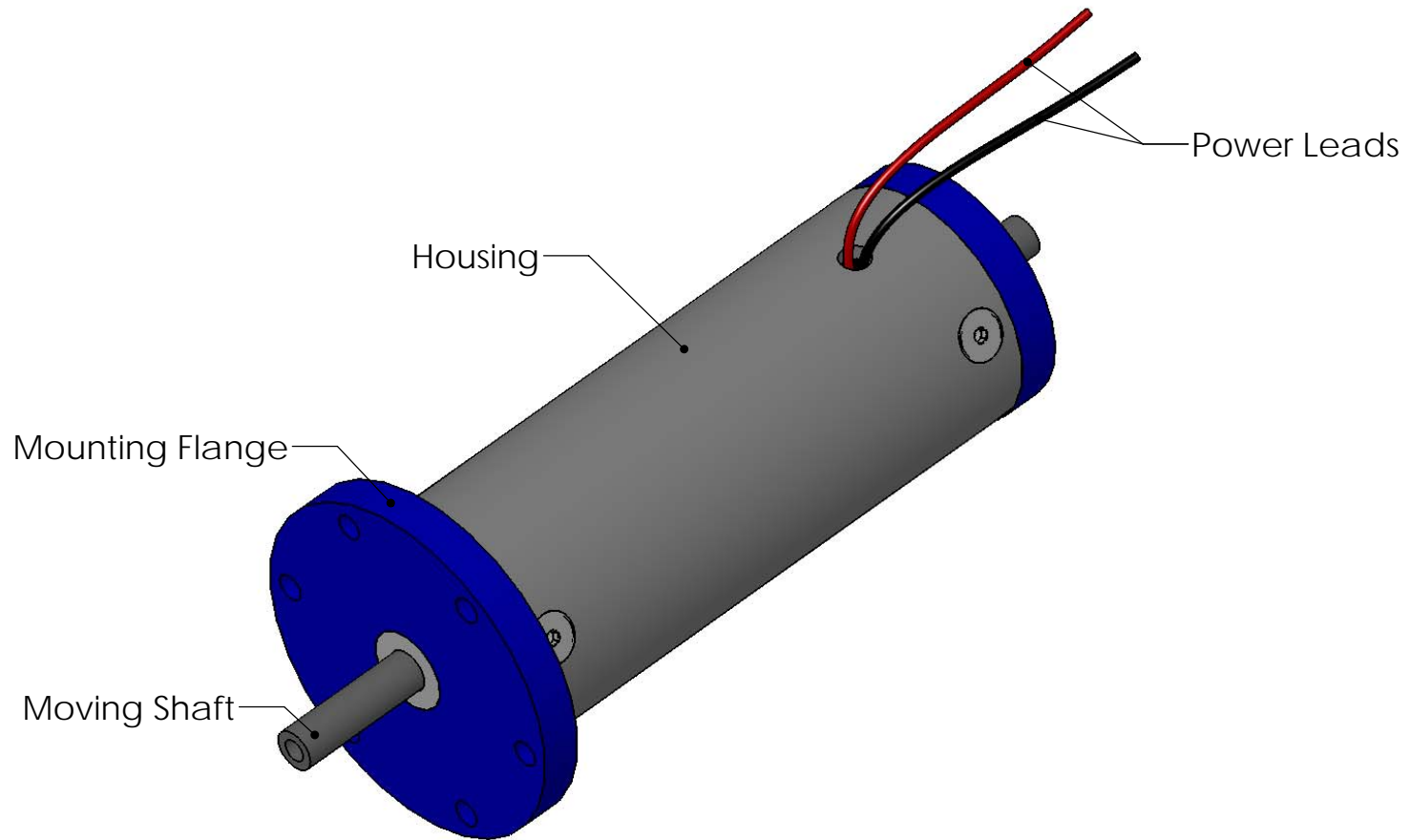

FRONT

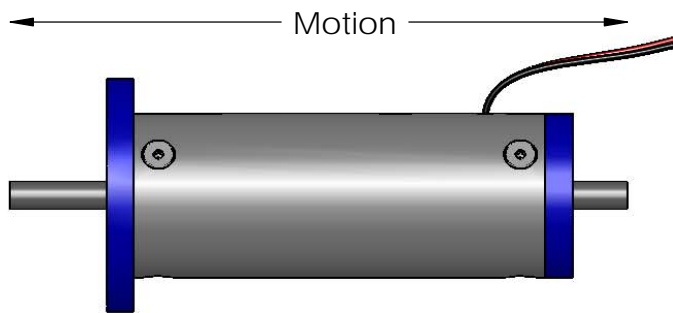

SIDE

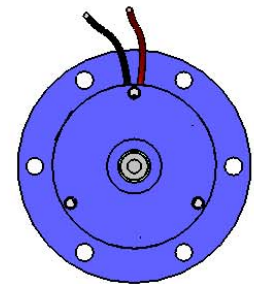

BACK

NCC (MOVING COIL)

NCC01-04-001-1X

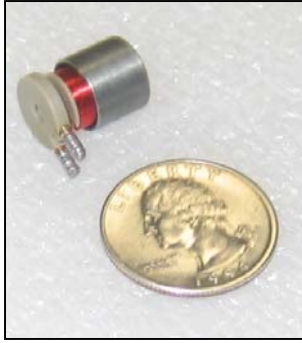

NCC03-14-010-1SL



NCC03-15-050-2X

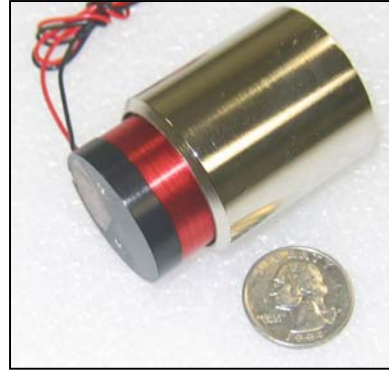

NCC05-11-011-1X

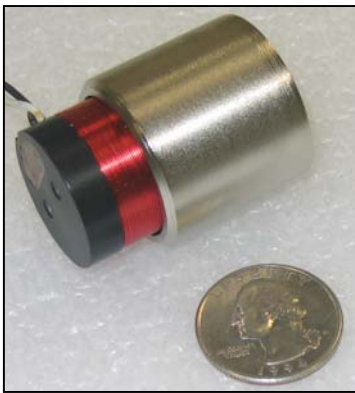

NCC05-18-060-2X



NCC06-60-500-1X



NCC10-15-023-1X



NCC20-18-020-1X



NCC52-20-020-1X



NCC06-08-005-2X



Model # NCABB - CC - DDD - EX

where:

A is C for moving coil or M for moving magnet

BB is the stroke (05 is 0.5 inch)

CC is the outside housing diameter (15 is 1.5 inch)

DDD is continuous force in lbs (140 is 14.0 lbs)

E is the number of poles

X is for special options

NCM (MOVING MAGNET)

NCM02-05-005-4JB

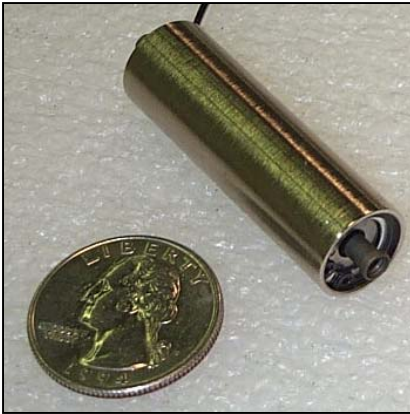

NCM04-25-250-2LVE



NCM05-05-005-2JB



NCM05-23-100-3LB



NCM05-28-180-2X



NCM10-15-020-2LB



NCM30-25-090-2X



CLOSED LOOP VOICE COIL POSITIONING STAGES

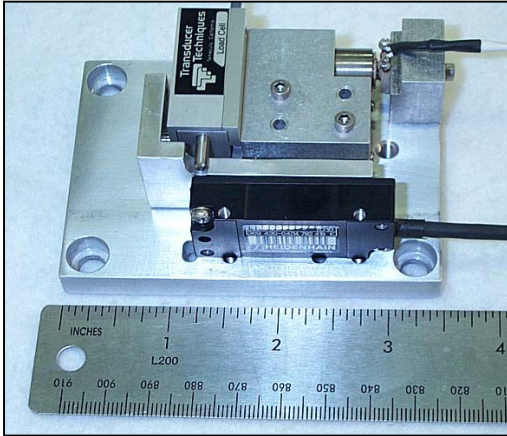

Dual Feedback

0.125" stroke, 25 grams force (Max) 0.1 μm encoder resolution
0.1 grams force resolution

*Force and encoder feedback

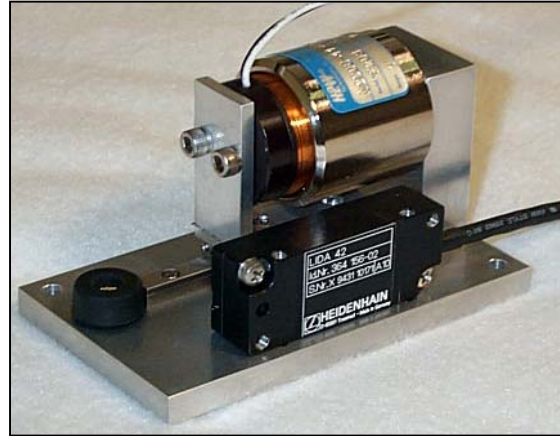

Short Stroke

0.5" stroke, 1 lbs cont., 3 lbs peak,
1 μm encoder resolution



Compact

1.0" stroke, 2.3 lbs cont., 6.9 lbs peak, 1 μm encoder resolution
*6" x 2" x 2.85"

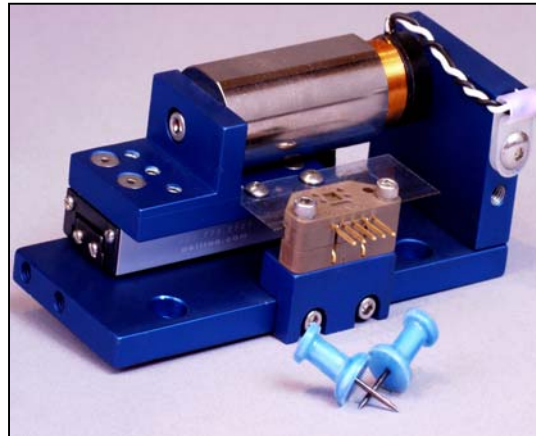

Compact (Low Cost)

0.60" stroke, 0.50 lbs cont., 1.50 peak,
12 μm encoder resolution
*3.75 x 1.75" x 1.53"



High Force

0.8" stroke, 27 lbs cont., 60 lbs peak
1 μm encoder resolution

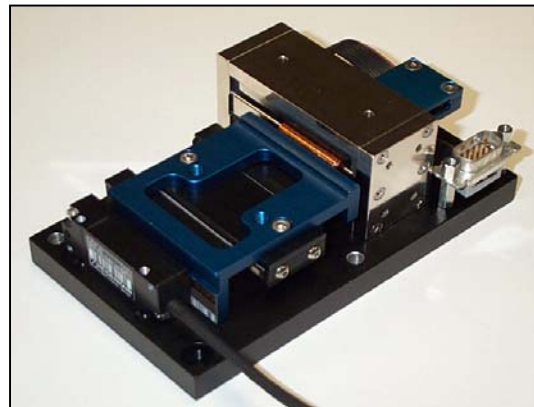

High Resolution

1.0" stroke, 3 lbs cont., 9 lbs peak
0.1 μm encoder resolution

LINEAR INDUCTION MOTORS



Linear Induction Motor



Travel	Unlimited	Unlimited
Velocity	1800 in/sec	45 m/sec
Acceleration	5 g's	5 g's
Peak Force	214 lbs	[950 N]
Continuous Force	43 lbs	[190 N]

What Is A Linear Induction Motor?

A Linear Induction Motor (LIM) is a non-contacting, high speed, linear motor that operates on the same principal as a rotary, squirrel cage, induction motor. They are capable of speeds up to 1800 in/sec [45 m/s] and are typically used in applications where accurate positioning is not required. LIM's can also be operated at stall to produce static thrust

The 3-phase coil assembly can be directly connected to the AC line for single speed applications or to an adjustable frequency drive for precise variable control of the speed of the motor. The motors are reversible and can also be dynamically braked.

The laminated coil assembly (shown above) is used in conjunction with a customer supplied aluminum and steel reaction plate to produce a force. A customer supplied bearing system is required to maintain the .040" - .060" [1 - 1.5 mm] air gap between the coil assembly and the reaction plate. The length of the reaction plate is equal to the coil length plus the stroke.

The amount of thrust produced by the LIM is proportional to the active surface area of the motor.

There is an attractive force between the coil assembly and the steel in the reaction plate only when power is applied to the coil assembly.

Multiple coil assemblies can used together to produce larger forces.

If the reaction plate is a disc, then rotary motion can be produced.

Either the LIM or the reaction plate can move while the other is fixed.

In hostile environments a non-magnetic stainless steel barrier can be used between coil assembly and the reaction plate to provide a seal.

Advantages:

- Only 2 parts
- Wide speed range
- No Maintenance
- Non-contact
- Ease of Control and Installation

Applications:

- Conveying Systems
- Cranes Drives
- Baggage Handling
- Vision Inspection Equipment
- Personal Rapid Transport Systems
- Theme Park Rides

The LIM consists of 2 main components;

- **3 Phase Coil Assembly:** The coil assembly is comprised of a 3-phase winding that is wound and inserted into a steel lamination stack with thermal protection devices. The entire assembly is then encapsulated with thermally conductive epoxy. Steel Angles with mounting holes are provided for mounting the coil assembly to the customers system. The coil assembly is available in many different widths and lengths, to meet the customers force and packaging requirements. The coil assembly can be used in a *single sided* or *double-sided* configuration. The single sided configuration consists of a single coil assembly that is used in conjunction with an aluminum plate backed by a steel reaction plate. The double-sided configuration is where 2 coil assemblies are facing each other, separated by a gap of .25" [6 mm] and only an aluminum reaction plate passes thru the gap. Multiple coil assemblies can be used together to produce larger forces. The standard sizes for the coil assemblies are shown on the following page.
- **Reaction Plate:** The customer supplied reaction plate is required for proper operation of the LIM. The reaction plate is made up of standard, readily available 1018 steel, aluminum, and / or copper. For *single sided* operation, the required reaction plate consists of a .125" [3 mm] thick aluminum or a .080" [2 mm] thick copper plate that is backed by a .25" [6 mm] thick ferrous steel plate. The steel plate can be omitted but the force will be dramatically reduced. For *double-sided* operation only a conductive plate of copper or aluminum is required.

SINGLE SIDED

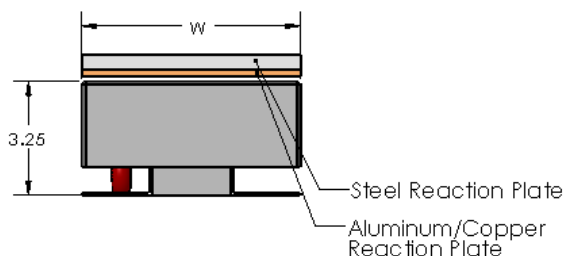

DOUBLE SIDED

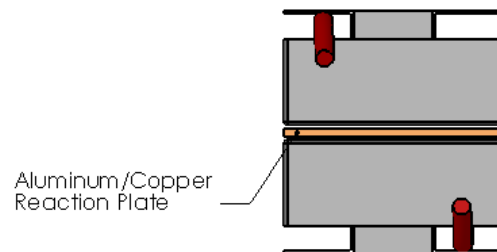

Required Electronics:

A 3-phase AC voltage directly from the line, an adjustable frequency supply, or a vector drive can be used to drive the LIM. The LIMs can be supplied for single phase AC, but the result is a less efficient motor. All standard voltages are available; 220, 380, 400, 415, 460, 600 @ 50 / 60 Hz

The speed of the LIM is proportional to the input frequency (which can be variable) and the pole pitch of the lamination stack (which is fixed). Connecting directly to the AC line at 50 or 60 Hz will produce a constant linear speed. Using an adjustable frequency drive (or inverter) will allow speeds as slow as 6 in/sec [0.15 m/s] and as fast as 1800 in/sec [45 m/s] at 400 Hz.

Mounting:

There are thru holes in the angles of the coil assembly for mounting to the customers system.

Ordering Info:

Individual LIM's can be ordered for any peak force up to 214 lbs [950 N]. Higher forces can be achieved by adding additional coil assemblies in series.

Single Sided LIM

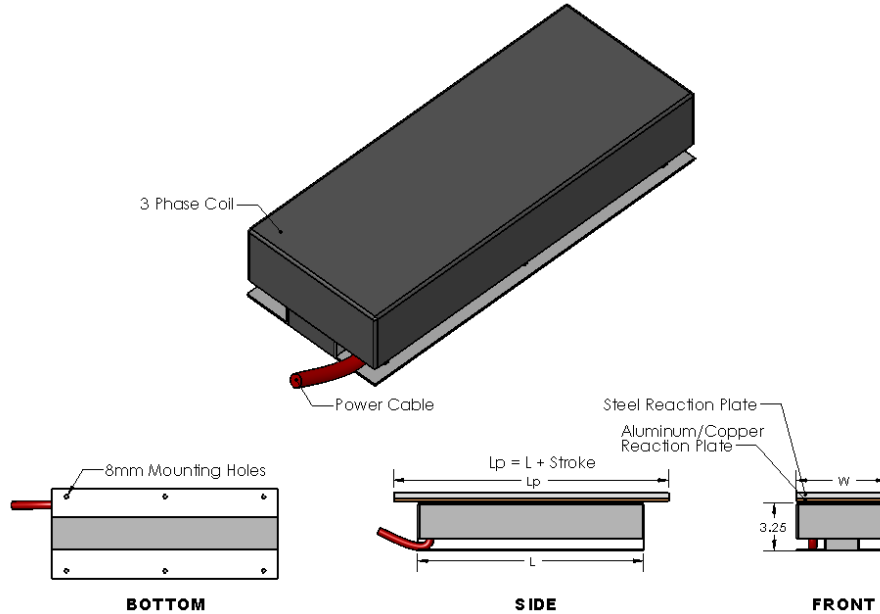

Model #	Fc		Fp		Ic	Ip	L		W	Weight		
	lbs	[N]	lbs	[N]			In	[mm]		In	[mm]	Lbs
LMA-03-020	4	[18]	20	[90]	0.6	3.0	6.9	[175]	5.5	[140]	13	[6]
LMA-05-030	6	[27]	30	[135]	0.9	4.5	11.0	[280]	5.5	[140]	22	[10]
LMB-03-026	5	[23]	26	[115]	0.7	3.5	6.9	[175]	6.3	[160]	17	[8]
LMB-05-038	8	[34]	38	[170]	1.0	5.0	11.0	[280]	6.3	[160]	28	[13]
LMB-07-051	10	[45]	51	[225]	1.4	7.0	15.4	[390]	6.3	[160]	40	[18]
LMC-07-066	13	[59]	66	[295]	1.7	8.5	15.4	[390]	7.5	[190]	51	[23]
LMC-09-081	16	[72]	81	[360]	2.1	10.5	19.7	[500]	7.5	[190]	66	[30]
LMD-09-101	20	[90]	101	[450]	2.6	13.0	19.7	[500]	8.7	[220]	82	[37]
LMD-11-118	24	[105]	118	[525]	3.0	15.0	23.8	[605]	8.7	[220]	100	[45]
LMD-14-143	29	[127]	143	[635]	3.7	18.5	28.0	[710]	8.7	[220]	117	[53]
LME-14-164	33	[146]	164	[730]	4.2	21.0	28.0	[710]	9.8	[250]	139	[63]
LME-16-189	38	[168]	189	[840]	4.8	24.0	32.3	[820]	9.8	[250]	161	[73]
LME-18-214	43	[190]	214	[950]	5.4	27.0	36.4	[925]	9.8	[250]	183	[83]

Fc= Continuous Force @ 460V 3 phase @ 100% Duty, Fp = Peak Force @ 460V 3 phase @ 20% Duty
 Ic = Continuous Current @ 460V 3 phase @ 100% Duty, Ip = Peak Current @ 460V 3 phase @ 20 % Duty

Model # LMX-AA-BBB

where: X is the width from A to E
 AA is the number of poles
 BBB is the Peak Force (Fp) in lbs

(i.e. LMC-09-081 is 7.5" wide Linear Induction Motor with 9 poles and a Peak Force of 81 lbs)

Single Sided LIM

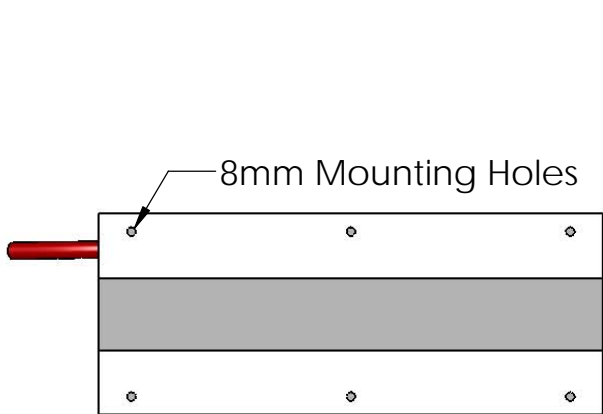
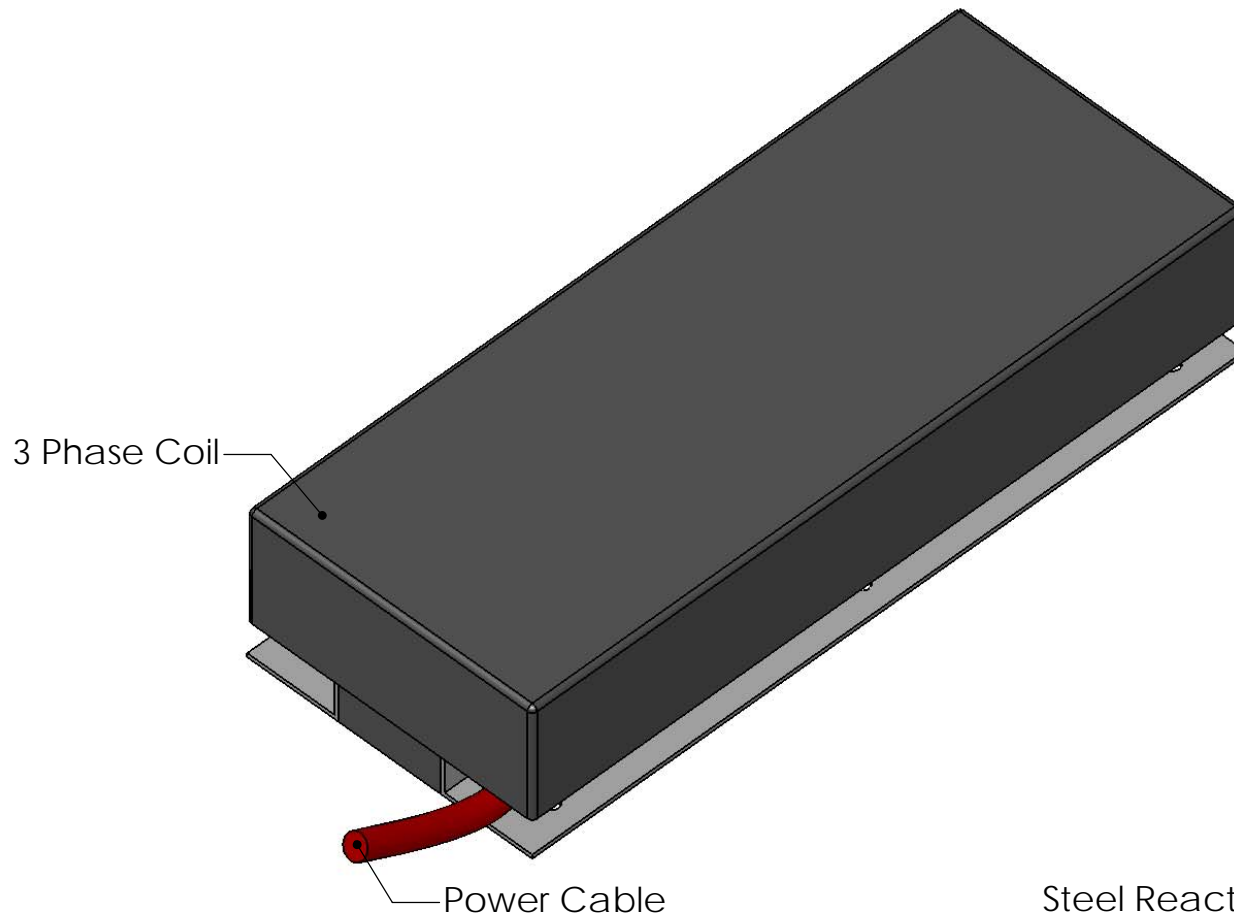

BOTTOM

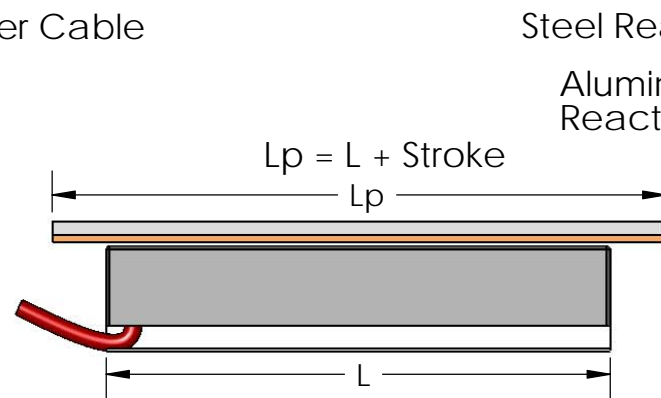

SIDE

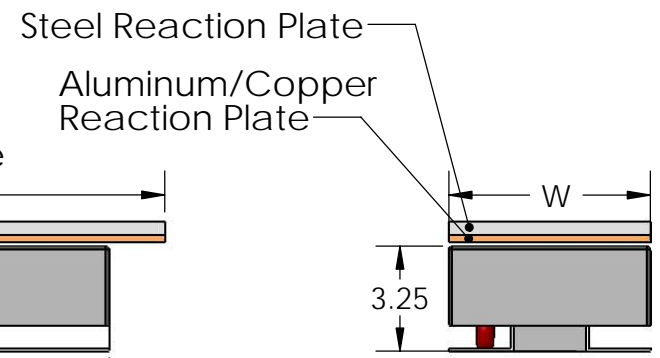

FRONT

LINEAR INDUCTION MOTORS

LMS-350-12

75 lbs force, 230 VAC, 3 phase, 60 HZ, 20A, 12% D.C.



LMB-02-025

25 lbs force, 230 VAC, single phase, 60 HZ, 20% D.C



LMB-04-065

65 lbs, 230 VAC, 3 phase, 60 HZ, 15% D.C



LMB-04-070-FC

460 VAC, 3 phase, 20 HZ, 70% D.C., 12A, 75 lbs thrust, fan cooled



LIMITED ANGLE TORQUE MOTORS



Limited Angle Torque Motors

H2W Technologies **Limited Angle Torque Motors** are ideal for compact, limited angular excursion (<180°), rotary, closed loop servo applications. Unlike conventional rotary brush and brushless motors, the torquers are wound in such a way that no commutation is required for motion to occur. The result is a much simpler and more reliable system.

Torquers operate on the principal of the **Lorentz Force (Torque) Equation**

$$\text{Force or Torque} = B \times I$$

where: B = Flux density (Tesla)

I = Current (Amps)

Simply stated, a current carrying conductor placed in a magnetic field will have a force (or torque) exerted upon it. This force is proportional to the direction and magnitude of the current and the flux density field. Since the permanent magnet flux density field is fixed, the direction of the rotation depends on the polarity of input current and the amount of torque that is produced is directly proportional to the magnitude of the input current.

A DC linear servo amplifier is required to provide power to the torquer.

The torquers are typically supplied unboxed without bearings or a shaft, but can be supplied boxed if required.

Coupling the torquer to your bearing system and a rotary encoder or other feedback device yields a system that is capable of intricate angular position, velocity, and acceleration control.

Low moving inertia of the rotor assembly allows for high angular acceleration of the payload.

The small length to diameter ratio allows the torquers to fit in spaces where conventional rotary brush and brushless DC motors will not.

It should be noted that, angular excursions of greater than 180° (up to 360°) can be achieved by modifying the winding of the stator assembly. In this case the coil assembly will have 4 leads and it will have to be commutated.

Advantages:

- No Torque Ripple
- High Angular Acceleration
- No Commutation
- Brushless
- Low Profile

Applications:

- Aerospace
- Semiconductor
- Medical
- Military

H2W Technologies offers 2 distinct types of limited angle torque motors.

1. **MR Series Limited Angle Torque Motor** - is a toroidally wound iron core stator with a 2, 4 or 6 pole permanent magnet rotor. This torque motor can provide angular excursions up to 180°. It is typically supplied without bearings, shaft or housing to allow for direct mounting to customer supplied bearing system.

2 Pole MR Torquer

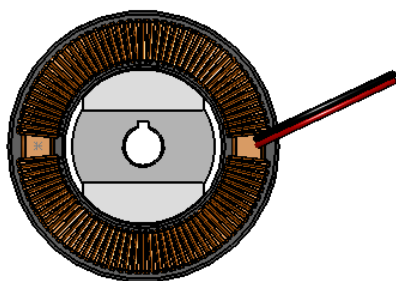

4 Pole MR Torquer

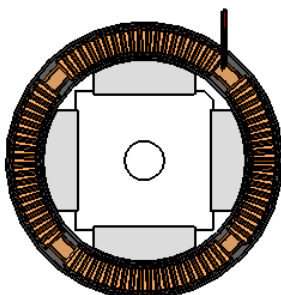

6 Pole MR Torquer

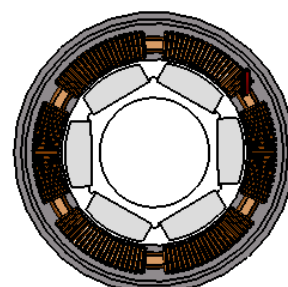

The **MR Series** is comprised of a toroidally wound, stationary, coil assembly with a multi-pole permanent magnet rotor.

Rotor: The rare earth permanent magnet rotor always has an even number of poles, with any where from 2 to 6 poles. The maximum angular excursion with a 2-pole rotor is 180°, with a 4 pole rotor is 90°, and with a 6 pole rotor is 60°. The torque will drop off to zero at the extreme ends of the travel. For constant torque over the required rotation, the angular excursion will always be less than numbers mentioned above.

The rotor is comprised of steel core with a thru hole for attaching the rotor to the shaft. Radially magnetized, multipole, rare earth, permanent magnets are bonded to the steel core. Depending on the application either Neodymium or Samarium Cobalt magnets are used.

Stator: The stator is comprised of a "soft" magnetic steel toroid that is electrically insulated. Multiple sections of insulated copper magnet wire are toroidally wound on the stator toroid. Only 2 leads are brought out from the stator assembly.

The rotor assembly is installed within the ID of the stator assembly. There is a magnetic attractive force between the stator and the rotor. When the stator is perfectly concentric within the rotor, the radial magnetic attractive forces are equal and opposite and they cancel each other out.

2. **WR Series Limited Angle Torque Motor** – is an arc segmented multipole permanent magnet stator with a low inertia copper magnet wire rotor. Angular excursions are typically less than 90°. This torquer is supplied with out a shaft or bearing.

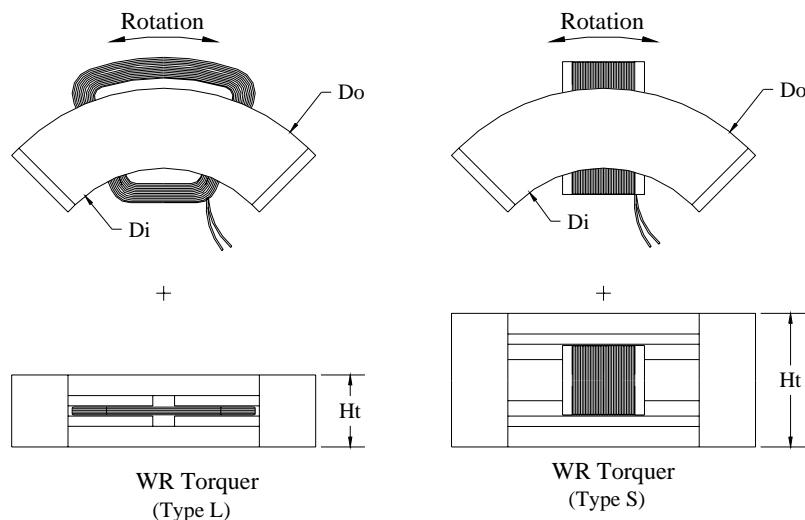

The **WR Series** is comprised of a stationary, arc segmented, multipole permanent magnet stator assembly with a low inertia wound wire rotor.

Rotor: The rotor is made up of a single coil of bondable copper magnet wire. The coil is wound and preformed into the desired shape. It is held together with the bonding agents in the wire. It can be encapsulated with aluminum or plastic brackets in order to provide a means for mounting the rotor to the bearing system and payload. The maximum angular excursion is less than 90°.

Stator: The stationary stator assembly consists of multipole permanent magnets that are bonded to steel plates. The 2 opposing steel plates are spaced apart to provide a gap using end plates. The coil rotor assembly moves angularly within this gap. There is no magnetic attractive force between the stator and the rotor.

The **WR Series** Torquer is available in 2 configurations.

The low profile (**Type L**) configuration has a smaller overall height which allows it to fit in a more compact space, but has less angular rotation for a given stator arc segment.

The second configuration (**Type S**) has a larger overall height but has typically twice the angular rotation per given stator arc segment when compared to the Type L torquer.

Required Electronics:

The motor requires a 1 phase brushless linear amplifier with power supply, that is rated with sufficient current and voltage to meet the motion requirements. A linear amplifier is required because of the very low inductance of the torquer coil assembly. A programmable motion controller is required to close the position loop on the system.

Environmental Considerations:

The torquer is a precision device with sensitive components, it should not be mounted in an environment that is wet or excessively dirty. The magnetic assembly is highly magnetic, it should not be placed in an area where loose steel particles can be drawn into the magnetic gap.

The torquer should not be mounted in an environment with high ambient temperatures (>50°C).

Mounting:

The torquer is typically supplied with out bearings and a shaft. This allows for the stationary and moving parts of the torquer to be mounted directly to the customers rotary payload assembly. The 2 components of the torquer should be mounted such that they are concentric to one another within .001". The rotor and the stator will have a mounting provisions to allow for attachment to the customers system.

Maintenance:

The torquer requires no maintenance.

Ordering Info:

Torquers can be ordered for any angular excursion up to 360° and continuous torques up to 1000 ounce-inches. The torquers are built as the orders are placed, they are not stocked, as each customer requirement is different.

Model #

TMR – AAA – BB – CCC - D

or

TWR– AAA – BB – CCC - D

where: AAA is the angular rotation (120° is -120)
 BB is the OD of the torquer (3.5 inch width is -35)
 CCC is the continuous torque (250 oz-in is -250)
 D is for special options

TMR is the MR series torquer and TWR is a WR series torquer.

(i.e. TMR-120-35-250-0 is a 3.5" OD limited angle torque motor with a 120° angular excursion, 250 oz-in of continuous torque and no special options)

P/N	Continuous Torque Angular Displacement	Type	# of Poles	Continuous Torque	Peak Torque	Outside Diameter	Height	Housed w/ Bearings
				oz-in (Ncm)	oz-in (Ncm)	inches (mm)	inches (mm)	
TMR-010-002-2H	10°	MR	2	2 (1.4)	6 (5.2)	1 (25.4)	1.07 (27.2)	yes
TWR-010-250-8LST **	10°	WR	8	200 (141)	600 (423)	5.50 (139.7)	4.90 (124.4)	yes
TMR-016-007-6	16°	MR	6	4.0 (2.8)	11.0 (7.7)	1.60 (40.6)	0.40 (10.1)	no
TMR-020-010-4	20°	MR	4	10 (7.1)	30 (21.3)	2.2 (55.9)	0.6 (15.2)	no
TMR-020-270V	20°	MR	4	265 (187)	795 (560)	5.25 (133.4)	1.70 (43.2)	no
TMR-040-010-4	40°	MR	4	10.0 (7.0)	30.0 (21.1)	2.50 (63.5)	0.60 (15.2)	no
TMR-040-438-4H	40°	MR	4	438 (309)	1314 (927)	4.25 (108)	2.7 (68.6)	yes
TMR-040-875-4H	40°	MR	4	875 (617)	2625 (1851)	5.54 (141)	2.7 (68.6)	yes
TMR-060-005-2H *	90°	MR	2	5.0 (3.5)	15.0 (10.6)	1.78 (45.2)	1.12 (28.4)	yes
TMR-060-100-2V	60°	MR	2	250 (176)	750 (529)	4.50 (114.3)	1.85 (46.9)	no
TMR-075-10-005-2H	75°	MR	2	1.0 (0.7)	3.0 (2.1)	1.00 (25.4)	0.60 (15.2)	yes
TWR-100-182-400-3P***	100°	WR	3	400 (282)	1200 (846)	18.20 (462.2)	1.45 (36.8)	no

* Can be supplied with encoder

** Water proof (IP-67), supplied with tachometer

*** Arc segmented torquer

MR indicates permanent magnet rotor

WR indicates wound rotor

Please Note: The maximum angle of rotation is 360 degrees divided by the number of poles, however the angle indicated above indicates continuous torque range, which is in the middle of the angle of rotation. Outside of that range, the torque generated decreases.

2 Pole MR Torquer

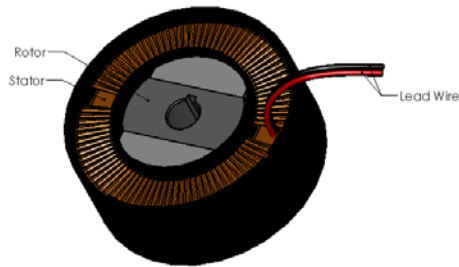

4 Pole MR Torquer

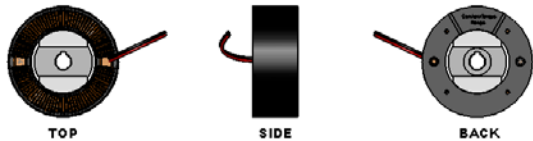
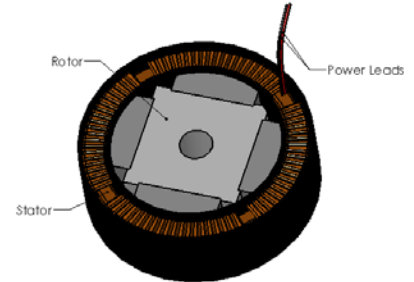

6 Pole MR Torquer

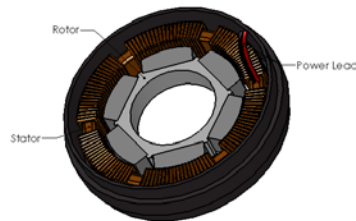

2 Pole MR Torquer

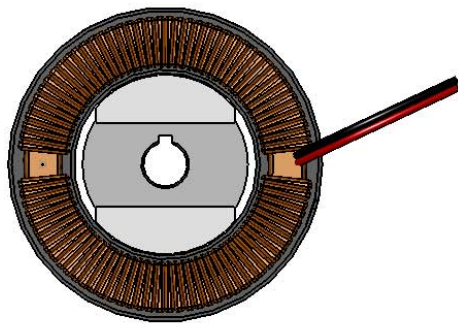
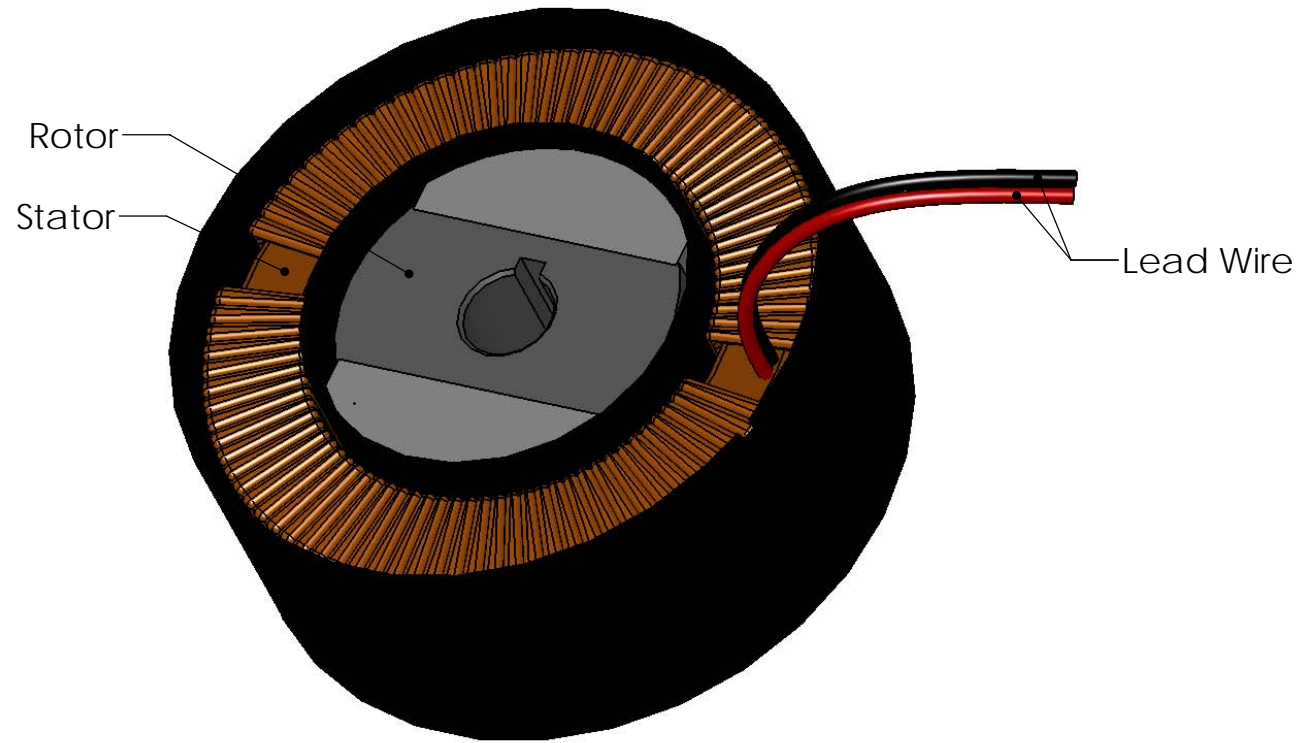

TOP

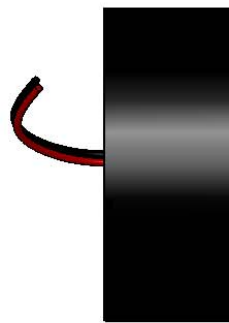

SIDE

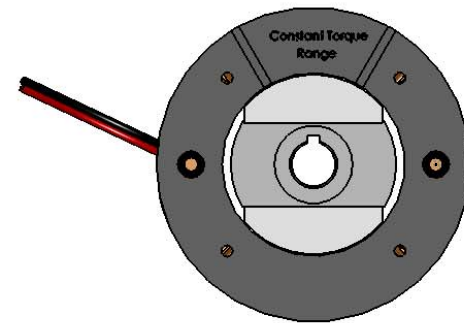

BACK

4 Pole MR Torquer

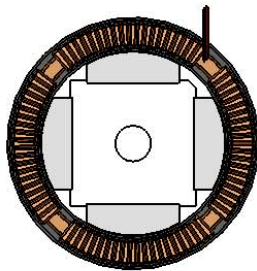
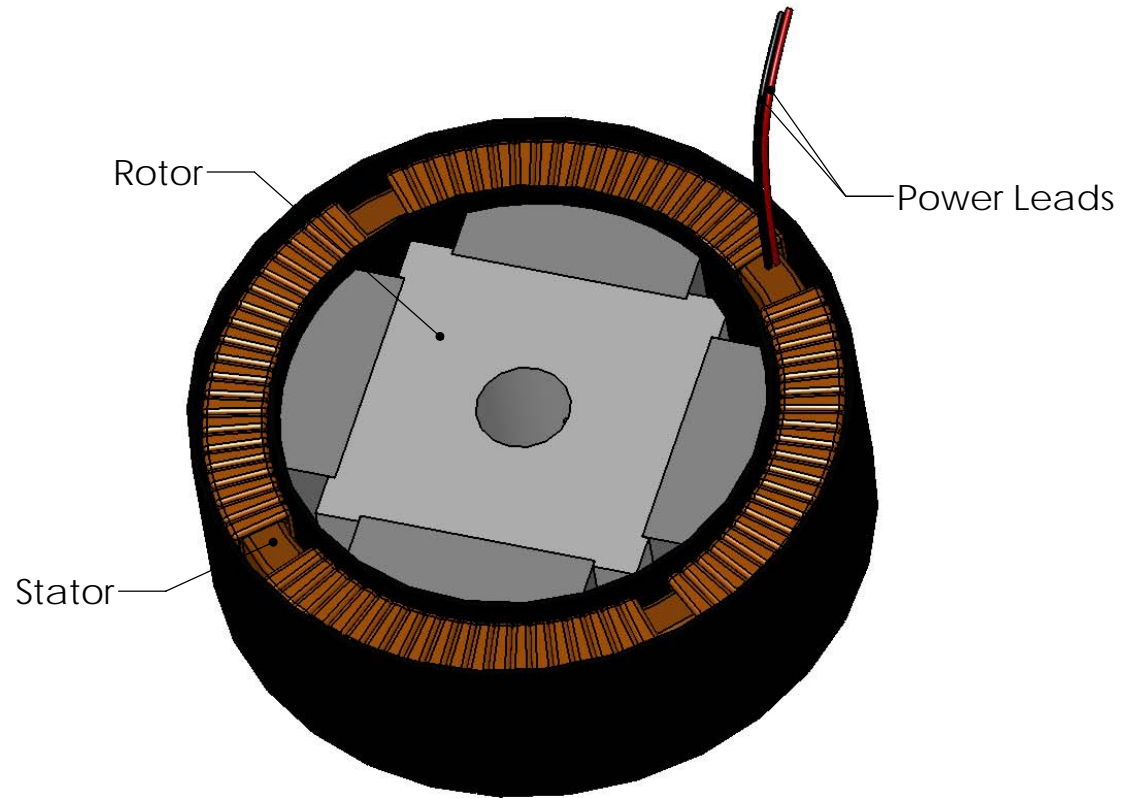

TOP

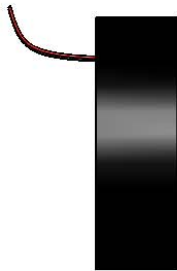

SIDE

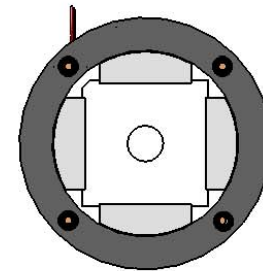

BOTTOM

6 Pole MR Torquer

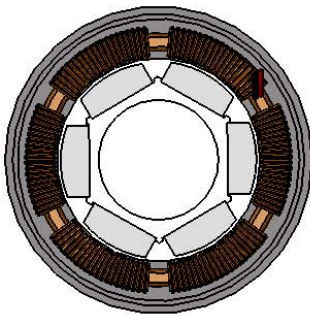
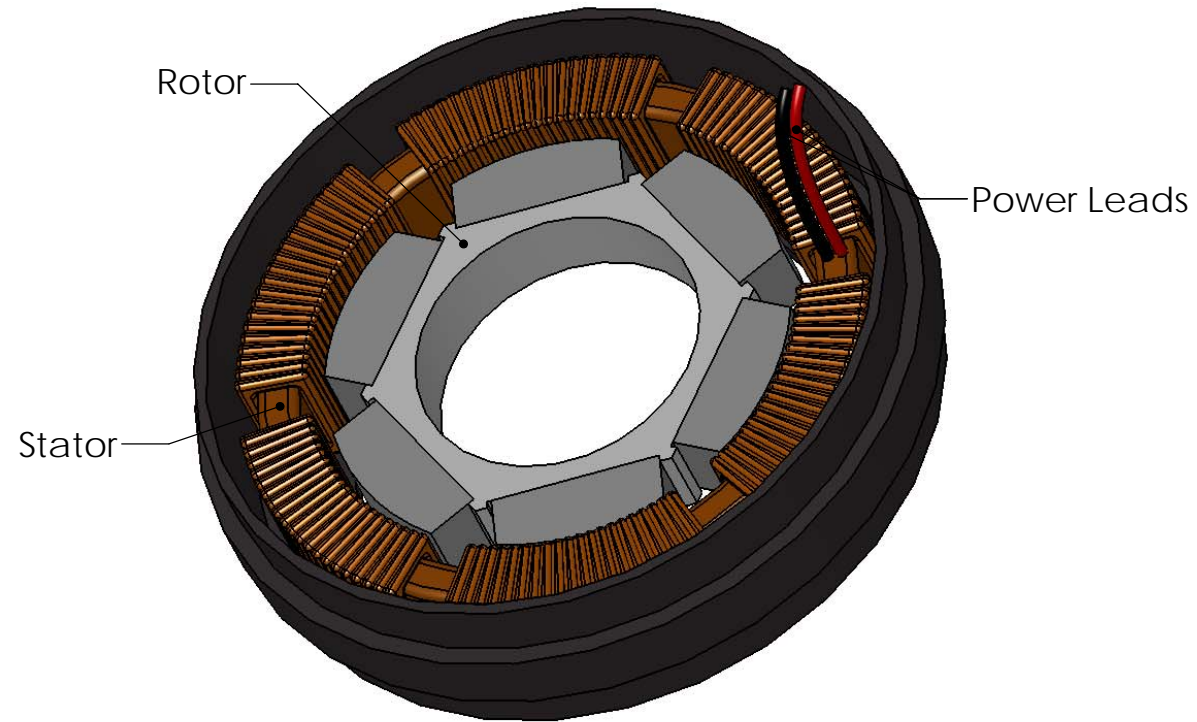

TOP

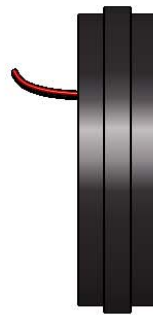

SIDE

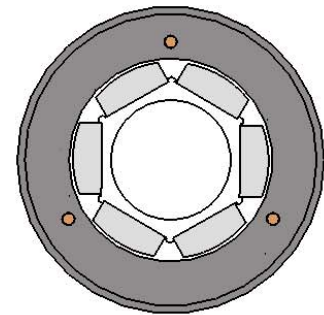

BACK

2 Pole MR Torquer

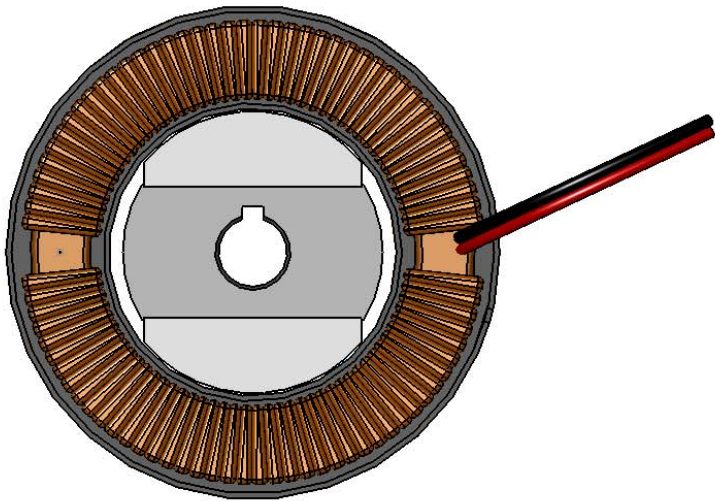

4 Pole MR Torquer

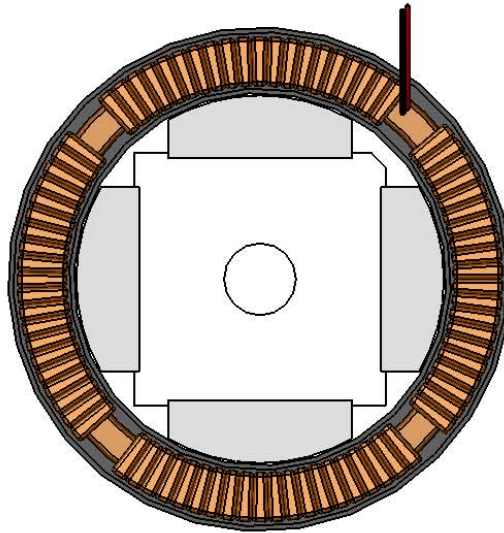

6 Pole MR Torquer

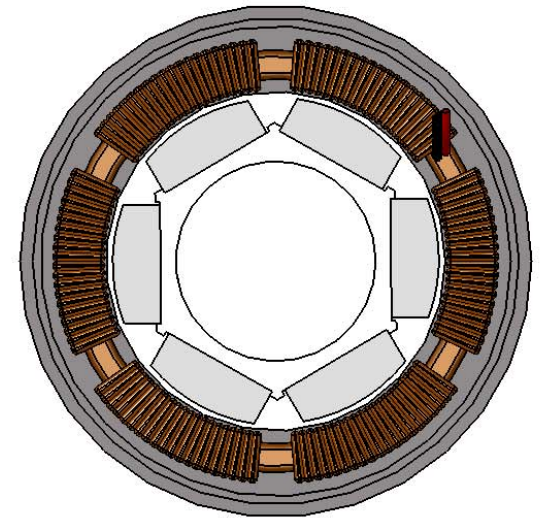

LIMITED ANGLE TORQUE MOTORS

TMR-010-002-2H

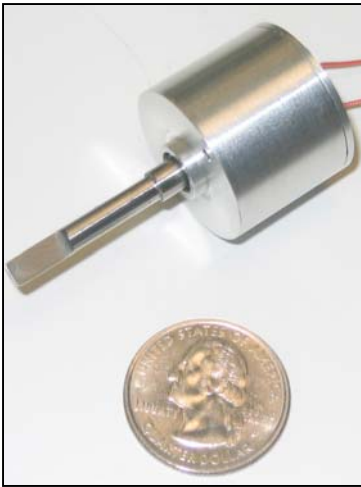

TMR-016-007-6



TMR-020-010-4



TMR-040-010-4

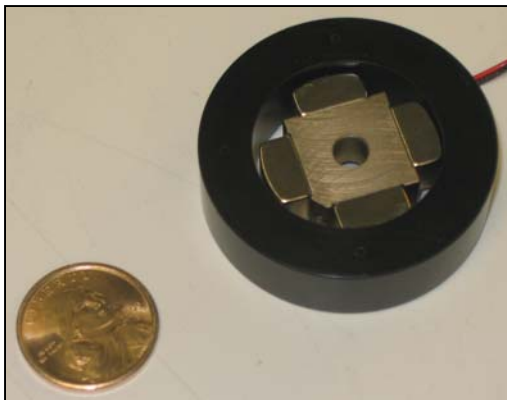

TMR-060-005-2

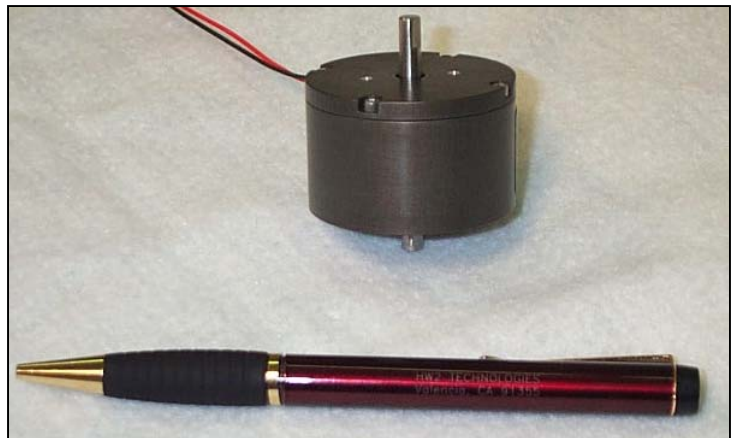

TMR-060-100-2V

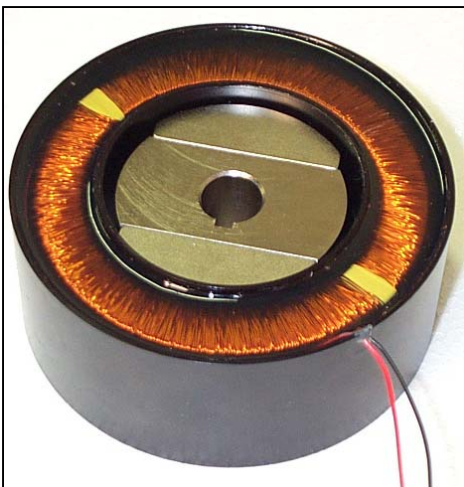

TMR-075-10-005-2H

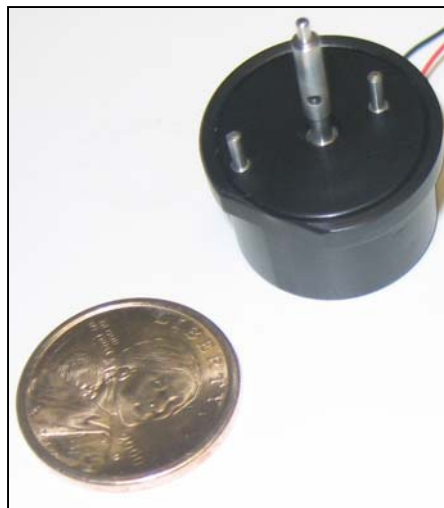

TWR-010-250-8LST

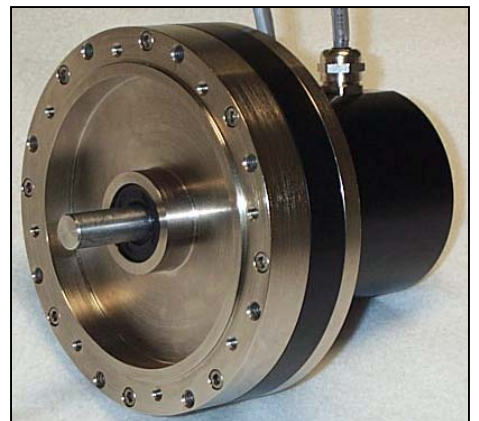



28310-C Ave Crocker • Valencia, CA 91355
E-mail: info@h2wtech.com
Call Toll Free: 888.702.0540
Phone: 661.702-9346 • Fax: 661.702.9348

Technologies, Inc.

Innovation in Linear Motion

Linear Stepper Motor Stage

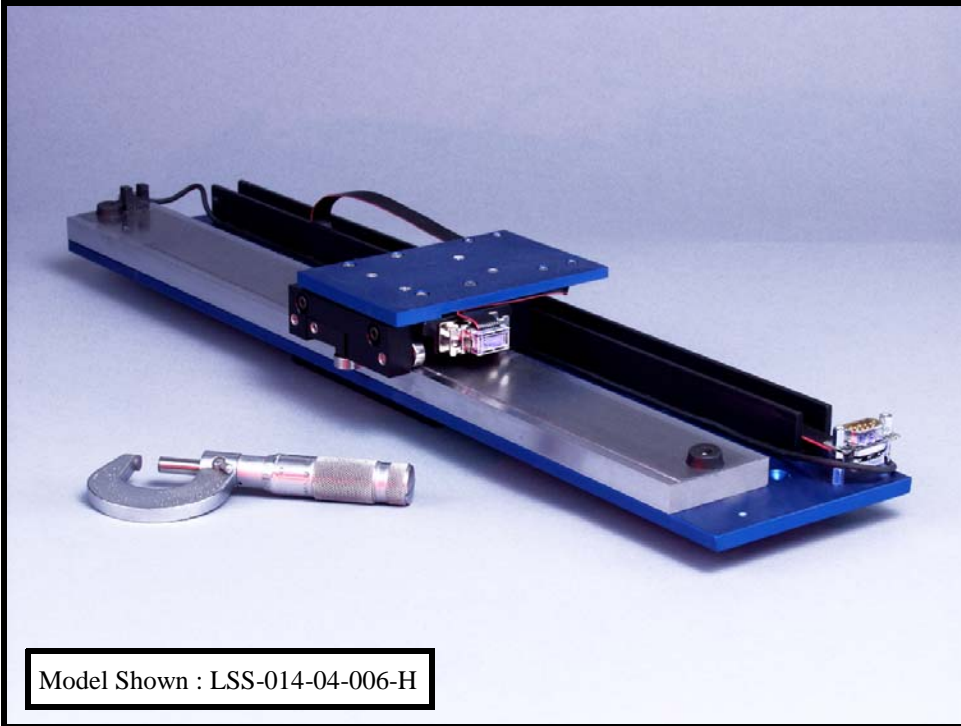

Model Shown : LSS-014-04-006-H

SPECIFICATIONS:

Travel = Up to 144 inches (3.6 m)

Speed = Up to 80 inches / sec (2 m/s)

Forces Available = 2 lbs (9 N) ,
6 lbs (27 N),
10 lbs (45 N),
and 20 lbs (89 N).

Acceleration = Up to 1 G

Resolution = .00004 inches (1-micron)
with microstepping driver.

Accuracy = .001 inches/foot (typical)

Repeatability = .0004 inches/foot
(typical)

Typical Applications:

- Pick and Place
- Wire Bonding
- Parts Transfer
- Semiconductor Wafer Handling
- Inspection Machinery

To find similar products please visit our web-site at: <http://www.h2wtech.com>.

For help with this product, or selecting the proper linear motion product please call us at 888.702.0540 or e-mail us at info@h2wtech.com.

Options:

- 2 Phase or 4 Phase Wiring
- Linear encoder option
- End of travel Limit Switches
- Control packages available from H2W

Benefits:

- Simple design provides trouble-free precision control in open-loop operation, which is highly repeatable.
- Zero backlash.
- Long life high-flex ribbon cable used, to achieve over 100,000,000 cycles typically.



28310-C Ave Crocker • Valencia, CA 91355
E-mail: info@h2wtech.com
Call Toll Free: 888.702.0540
Phone: 661.702-9346 • Fax: 661.702.9348

Technologies, Inc.

Innovation in Linear Motion

IG 34 Frame Brushless Servo Motors

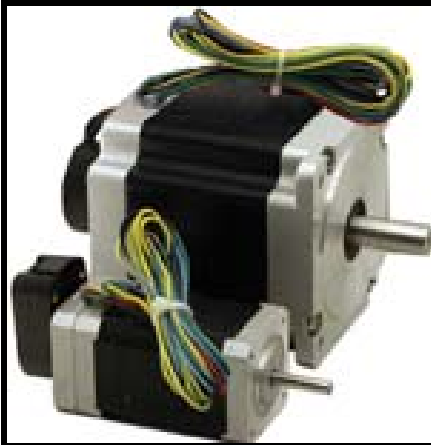

DESCRIPTION

The IG Instrument Rated DC brushless three-phase servomotor delivers high continuous torque in a cost reduced package and with an IP40 environmental rating.

The increased torque is the result of eight magnetic poles on the rotor compared to the traditional four magnetic poles. This design uses neodymium magnets for maximum performance. The IG series has an open-lamination design reducing cost. This series come with NEMA standard 17, 23, 34, and 42 flanges, and in three different stack widths with continuous torque rating from 25 to 820 oz-in (0.18 to 5.80 Nm). The IG's can come with or without halls sensors and with or without a rear shaft. The IG's can also be supplied with an incremental optical encoder with or without hall simulation tracks. To meet the different global requirements the output shaft comes in Imperial or Metric dimensions. These servomotors are also available with planetary gearheads and/or brakes.

Performance Specifications for 34 Frame Brushless Servo Motors

Stack Width A

Maximum Continuous Stall Torque:	7.26 lb-in	(.82 N-m)
Peak Stall Torque:	21.77 lb-in	(2.46 N-m)
Maximum Speed:	8000 RPM	
Weight:	4.19 lbs	(1.90 kg)
Rotor Inertia:	0.00071 lb-in-sec²	(0.80 kg-cm³)

Stack Width B

Maximum Continuous Stall Torque:	14.60 lb-in	(1.65 N-m)
Peak Stall Torque:	43.81 lb-in	(4.95 N-m)
Maximum Speed:	8000 RPM	
Weight:	6.39 lbs	(2.90 kg)
Rotor Inertia:	0.00142 lb-in-sec²	(1.60 kg-cm³)

Stack Width C

Maximum Continuous Stall Torque:	22.13 lb-in	(2.50 N-m)
Peak Stall Torque:	66.38 lb-in	(7.50 N-m)
Maximum Speed:	8000 RPM	
Weight:	8.60 lbs	(3.90 kg)
Rotor Inertia:	0.00212 lb-in-sec²	(2.40 kg-cm³)

To find similar products please visit our website at: <http://www.h2wtech.com>.

For help with this product please call us at 888.702.0540 or e-mail us at info@h2wtech.com.



28310-C Ave Crocker • Valencia, CA 91355
 E-mail: info@h2wtech.com
 Call Toll Free: 888.702.0540
 Phone: 661.702-9346 • Fax: 661.702.9348

Technologies, Inc.

Innovation in Linear Motion

BLS-1525 Brushless Servo Amplifier



DESCRIPTION

The BLS 1525 is designed to operate H2W's linear and rotary brushless servo motors. The BLS 1525 supplies 15 amps continuous current and 25 amps peak current at 150 VDC for a total of 2250 watts of continuous power. The BLS 1525 is a current source type PWM amplifier. The BLS 1525 is a power duplicator of the command signal. A battery, a motion controller, or a signal generator can be the source of the command signal input.

The BLS 1525 can operate in a Torque or Velocity mode. In the Torque mode, the BLS 1525 only closes the torque loop. The velocity loop is closed in the motion controller. In the Velocity mode, the BLS 1525 itself closes both the torque and velocity loop. Unless otherwise specified, the BLS 1525 is preset from the factory in the torque mode.

Performance Specifications

Peak Power	3.75 KW	Input Signal Voltage	+/-10 VDC (Typ), +/-35 VDC Max
Peak Output Voltage	+/- 150 VDC	System Gain	0 to 5100 amps/volt—Velocity Mode 0 to 10.0 amps/volt—Torque Mode
Peak Output Current	+/- 25 Amps (1 sec.)		
Max Continuous Current	+/- 15 Amps	Input Impedance	40 kOhms
Peak Current Limit	0 to 25 amps	Input Voltage	45-120 VAC
RMS Current Limit	0 to 19 amps	Physical Characteristics	2.6 lbs 7.6" x 2.5" x 2.5"
Signal Command Input	Scaling		
Balance	Zero velocity offset	Ambient Temperature	0 to 50 degrees C
Compensation	System Response	Shutdown Temperature	80 degrees C @ Heat Sink
Tachometer	Scaling	Relative Humidity	5 to 95% Non Condensing

To find similar products please visit our website at: <http://www.h2wtech.com>.

For help with this product please call us at 888.702.0540 or e-mail us at info@h2wtech.com.