

3 Phase Brushless Linear Motor



Travel	Unlimited	Unlimited
Velocity	240 inches / sec	[6 m/s]
Acceleration	12 G's	12 G's
Peak Force	600 lbs	[2669 N]
Continuous Force	200 lbs	[888 N]

The 3 phase brushless (or AC servo) linear motor is ideal for long stroke, closed loop servo, linear motion applications. They can be used at speeds up to 240 in / sec [6 m / sec]. They are capable of very precise position, velocity and acceleration control when coupled with a linear encoder.

The 3-phase coil assembly can be commutated trapezoidally using integral Hall Effects or sinusoidally using software commutation in conjunction with the appropriate motion controller and sinusoidal amplifier.

The short encapsulated moving coil assembly moves thru a gap in the long "U" shaped magnet assembly. A customer supplied bearing system is

required to guide the moving coil assembly and to maintain a .025" [0.63 mm] clearance between the magnet and the coil assembly.

The power to the motor (from a customer supplied PWM 3 phase brushless servo amplifier) is supplied to the moving secondary via a power cable.

Larger motors with higher forces are available, consult factory for details and drawings.

The motors are available in 3 different cross sections and 5 different coil assembly lengths.

Advantages:

- Zero cogging
- High speed and accelerations of light loads
- Low moving mass
- Uses standard 3 phase brushless amplifier

Applications:

- Pick and Place Machines
- Coordinate measuring machines
- Laser and Water jet cutters
- Vision Inspection Equipment

The Brushless Linear Motor consists of 2 main parts

- **Long Stationary Magnet Assembly:** The "U" shaped magnet assembly is made up of nickel-plated steel back iron and Neodymium permanent magnets. The magnets are bonded to the 2 parallel steel plates and the plates are bolted to a steel spacer bar. Threaded and thru holes are available in the steel back iron for mounting the magnet assembly to the customer supplied base plate. The magnet assembly is available in widths from 1.59" to 2.65" [40.4 mm to 67.3 mm]. The length of the magnet assembly is a function of the stroke. Single piece motors are available as long as 36 inches [0.91 m] for series BLSA & BLSB motors and 66 inches [1.67 m] for series BLSC motors. Longer motors will be supplied in modular sections.
- **Short Moving Coil Assembly:** The coil assembly is comprised of a 3 phase copper motor winding, an aluminum mounting bracket and an optional Hall Effect board that are all vacuum encapsulated with epoxy. Mounting holes in the aluminum bracket are provided for attaching the secondary to the moving member of the customer supplied table assembly. The coil assembly is available in many different widths and lengths, to meet the customers force and packaging requirements. Multiple coils can be supplied with a single magnet assembly to allow for independent moving heads or they can be coupled together to produce larger forces. The standard lengths for the coil assemblies are from 3.20" [81.3 mm] to 12.80" [325 mm].

Required Electronics:

The motor requires either a trapezoidal or sinusoidal 3 phase brushless amplifier with power supply that is rated with sufficient current and voltage to meet the motion requirements. The inductance of the linear motor coil should be greater than the minimum load inductance of the servo amplifier.

Environmental Considerations:

The brushless motor is an open type motor and should not be mounted in an environment that is wet or excessively dirty. It should be protected with some type of bellows or cover when installed by the customer.

Mounting:

The brushless linear motor should be mounted to flat (better than .003"/ft [246 microns / m] and stiff surface. Threaded and thru holes in the magnet assembly and threaded holes in the coil assembly are present for the mounting of the motor to the customers system. A cable carrier must be provided by the customer to route the motor and Hall Effect cable. The motor may be mounted in any orientation.

Ordering Info:

DC brushless motors can be ordered for any stroke and any peak force up to 240 lbs. Higher forces can be achieved by adding additional coil assemblies in series (consult factory for more information)

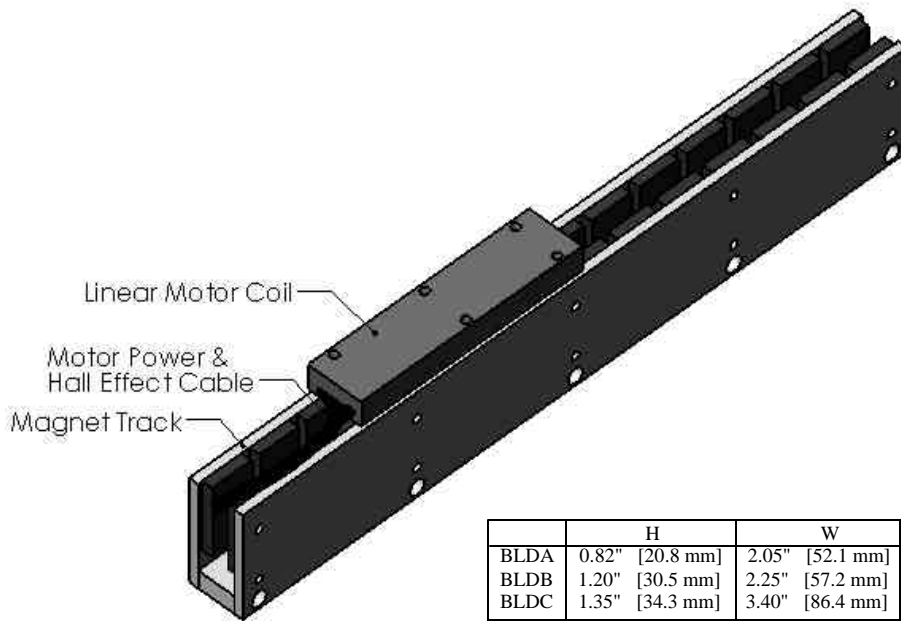

	H	W	A	B	C
BLDA	0.82" [20.8 mm]	2.05" [52.1 mm]	4-40 [M3]	6-32 [M3]	6-32 [M3]
BLDB	1.20" [30.5 mm]	2.25" [57.2 mm]	6-32 [M3]	8-32 [M4]	8-32 [M4]
BLDC	1.35" [34.3 mm]	3.40" [86.4 mm]	10-32 [M5]	10-32 [M5]	10-32 [M5]

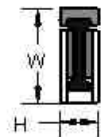
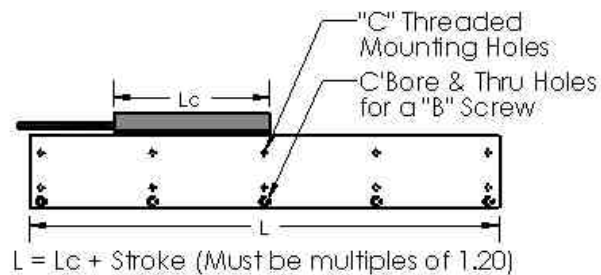
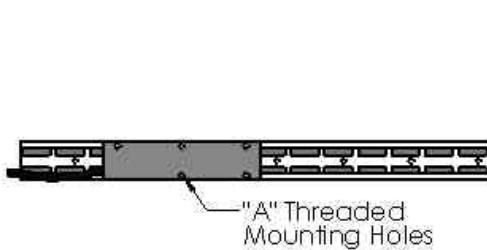

Model #	Kp lbs/amp [N/amp]		F cont lbs[N]		F peak lb [N]		I c amps	I p amps	Ve V/in/s V/m/s		Rc ohms	L mHenry	Lc In [mm]		Coil Weight lbs [Kg]
BLDA-01	1.5	[6.8]	5.5	[24.5]	16.5	[73.5]	3.6	10.8	0.20	[7.90]	3.8	1	3.2	[81.3]	0.27 [0.12]
BLDA-02	3.1	[13.7]	10	[45]	45	[202]	3.1	9.3	0.40	[15.7]	7.6	2	5.6	[142.2]	0.48 [0.22]
BLDB-02	4.9	[21.8]	14	[62.2]	38.7	[172]	2.6	7.8	0.64	[25.2]	11.8	4.8	5.6	[142.2]	0.6 [0.27]
BLDB-03	7.4	[32.7]	19	[84.5]	56.7	[252]	2.6	7.8	0.96	[37.8]	17.7	7.2	8.0	[203.2]	0.86 [0.39]
BLDC-02	6.1	[27.3]	20	[89]	60	[267]	3.4	10.2	0.80	[31.5]	8.6	6	5.6	[142.2]	1.22 [0.55]
BLDC-03	9.2	[40.9]	30	[134]	90	[402]	23.3	9.9	1.2	[47.2]	12.9	9	8.0	[203.2]	1.75 [0.79]
BLDC-04	12.3	[54.7]	40	[178]	120	[534]	3.2	9.6	1.6	[63]	17.2	12	10.4	[264.2]	2.27 [1.03]
BLDC-05	15.3	[68.1]	50	[222]	150	[667]	3.2	9.6	2.0	[78.7]	21.5	15	12.8	[325.1]	2.8 [1.27]
BLDC-06	18.4	[81.8]	60	[267]	180	[800]	3.2	9.6	2.4	[94.5]	25.8	18	15.2	[386.1]	3.36 [1.53]
BLDD-03	18.4	[81.8]	75	[333]	225	[1000]	4.2	12.6	2.4	[94.5]	12.0	15	11.2	[285]	5.0 [2.27]
BLDD-04	24.5	[109]	100	[444]	300	[1334]	4.1	12.3	3.2	[126]	16.0	20	14.6	[369]	6.5 [2.95]
BLDD-05	36.8	[163.7]	150	[667]	450	[2000]	4.1	12.3	4.8	[189]	24.0	30	21.3	[541]	9.5 [4.32]
BLDD-06	49.1	[218.4]	200	[888]	600	[2669]	4.0	12.0	6.4	[252]	32.0	40	28.0	[711]	12.5 [5.68]

F cont = Continuous Force, F peak = Peak Force @ 10% Duty
 Kp = Force Constant, I c = Continuous Current, I p = Peak Current @ 10 % Duty
 Required DC Bus Voltage for Amplifier; $V_{required} = (I_{peak} \times R_c \times 1.4) + (\text{Back EMF} \times \text{Velocity})$