

High Speed Series

Brushless DC Motors

High Speed Housed and Frameless Brushless DC Motors



BH02302 housed motor with
encoder and housed BH03401



Frameless BH02301 motor
with fiberglass rotor sleeve

Engineering Guide

Hathaway
Emoteq, Inc

Emoteq, Inc

10002 E. 43rd St. So.,
Tulsa, Oklahoma 74146
Rep Tel 800 433 3434
Rep Fax 800 200 6963

High Speed Series

Brushless DC Motors

Product Features

BH Series Housed and Frameless Motors

The **BH Series** of three phase brushless motors was introduced as a family of general purpose servo motors. However, the four pole rotors and high operating efficiencies of the designs have meant that the majority of the motors supplied have been used in



BH02303 housed motor with holding brake and 1000 PPR encoder with line driver

high operating speed applications. The new Quantum Series of motors in sizes 17, 23, and 34 now satisfy requirements for small servo motors.

The BH Series motors are available in two diameters and various lengths to suit a range of applications for high speed motors. Hall effect sensors for commutation are integral to the motor and require no setup on

the part of the user.

The standard BH Series motors are available in two frame sizes of 2.3 and 3.4 inch (57.7 & 86.4mm) diameters. Additionally the motors are available in frameless configurations of 1.80 and 3.00 inch stator diameters (45.7 & 76.2mm).

BH Series motors are especially well suited to applications demanding high power density motors which minimize size, weight, inertia, and limit, through high operating efficiency, the power losses into the attached mechanical structure.

Due to the special nature of high speed systems, Emotek usually engineers the mechanical, electrical and magnetic designs for optimum efficiency based on the application requirements. Several different magnet containment methods are employed and depend on the operating speed of the motor as well as application environment parameters.

In addition to the BH Series, and to illustrate the expanding range of capabilities, data on some sample high speed motor designs is included in this engineering guide. For further assistance call 800 221 7572 USA or 918 627 1845 international.

High Speed Motor Model Numbering

A complete model number is comprised of a series designator, a frame size, frame length, winding designator, and mechanical changes and options. Model numbers for housed and frameless motors are the same except for the -H suffix indicating a housed motor. Certain options may only be specified with housed motors.

Motor Series Designator

BH Brushless, high speed (standard)
HS High Speed (high efficiency laminations)
HSS Low hysteresis laminations (very high speed)
SB Special versions

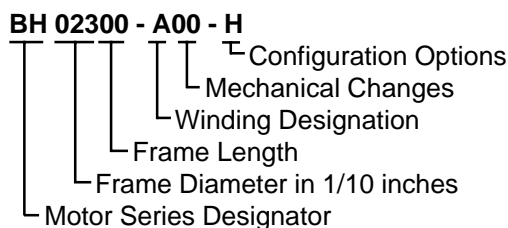

Frame Diameter

BH and QB motor housing diameters
HT/HS frameless stator diameter (inches)

Frame Length

No. of stacks. Stack length varies with series

Windings

-A00 Standard (catalog) design
-X00 Special winding (new design not released by engineering)
-A0X Standard winding, special mechanical design

Mechanical Changes

Issued in numerical sequence. See specific drawing.

Configuration Options

- H Housed motor
- HE Housed motor with encoder
- HB Housed motor with integral brake.
- HR Housed motor with resolver
- T Tachometer (housed or frameless motor)

High Speed Series

Brushless DC Motors

Product Features

Design Features of Emoteq's High Speed Motors

- High torque to inertia and size ratios
- High energy Neodymium Iron Boron magnets standard
- Rotor magnet sleeving incorporated into designs
- Integral Hall effect sensors for commutation
- Extensive range of standard designs
- Mechanical, electrical, and magnetic circuit changes readily undertaken
- Fast delivery on both standard and custom designs

Applications of High Speed Motor Technology

- Printed circuit board drilling spindles
- Laser scanning heads
- Image acquisition and reproduction
- High speed machining heads
- Semiconductor deposition and cleaning systems
- Silicon wafer slicing equipment
- Optical glass grinding



Frameless SB2500 motor with magnet sleeve for high speed operation.

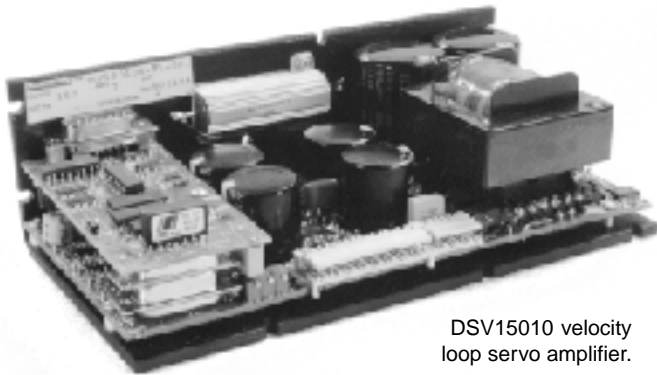

DSV15010 velocity loop servo amplifier.

Drive Electronics for High Speed Brushless Motors

Driving high speed brushless DC motors at maximum efficiency requires specially configured drive electronics. The DSV Series of amplifiers has been engineered with a special topology to deliver energy to the motor windings at only the commutation frequency of the motor instead of with Pulse Width Modulation. PWM stator energy control adds significant losses in the stator due to the high frequency switching employed in such drives.

However, while there are several methods available to achieve stator energy delivery, it is important that the drive also be capable of correctly controlling phase currents for reliability, driving in four quadrant velocity loop control for dynamic performance, and managing regenerated energy for power stage protection. Of course the DSV Series amplifiers have all these capabilities plus a host of other standard and optional features to simplify control system integration. Please inquire about drive electronics suitable for your high speed motor application.

DSV Model	Operating Voltage	Continuous Current	Peak Current
DSV04807	48	7	12
DSV04812	48	12	20
DSV15007	150	7	12
DSV15012	150	12	20
DSV30007	300	7	12
DSV30012	300	12	20

Hathaway
Emoteq, Inc

Emoteq, Inc (Main)
10002 E. 43rd St. So.
Tulsa, OK 74116
USA
Tel 800 433 3434
Rep Fax 800 200 6963

Emoteq UK
Box 772,
Rottingdean BN2 8ND
United Kingdom
Tel 01273 390800
Fax 01273 301060

High Speed Series

Brushless DC Motors

BH02300 Series

Frameless BH02300 Series

MODEL	"A" DIM.	"B" DIM.	"C" DIM.
BH02300	.500 (12.7)	.680 (17.3)	1.120 (28.5)
BH02301	1.150 (29.2)	1.330 (33.8)	1.770 (45.0)
BH02302	1.800 (45.7)	1.980 (50.3)	2.420 (61.5)
BH02303	2.450 (62.2)	2.630 (66.8)	3.070 (78.0)

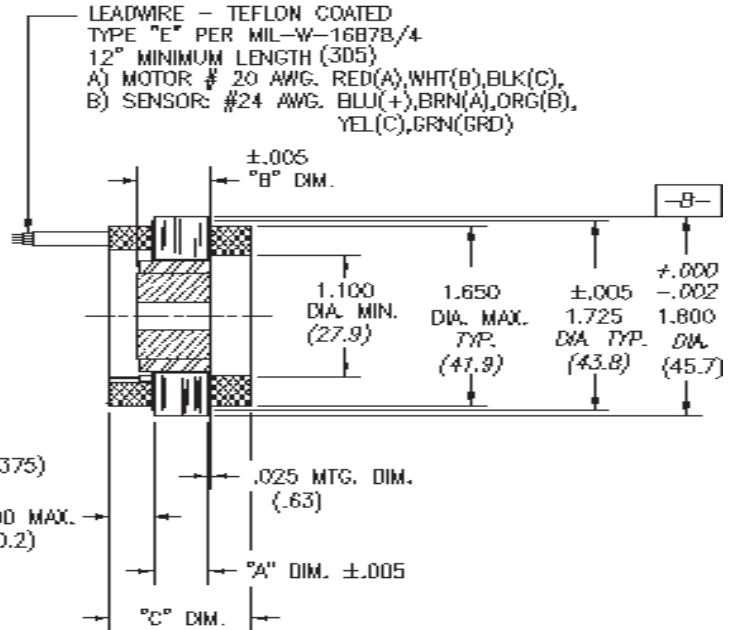
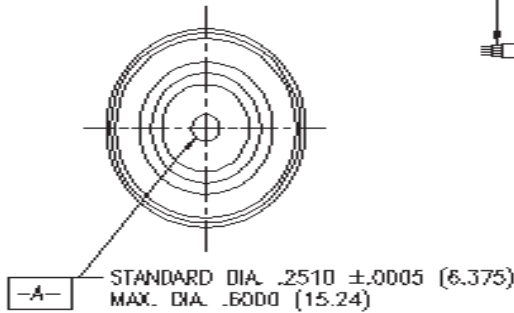

1. MOTOR SUPPLIED AS TWO SEPARATE COMPONENTS, ROTOR ASSEMBLY AND STATOR ASSEMBLY.
2. DIAMETERS "A" AND "B" TO BE CONCENTRIC WITHIN .002 WHEN MOUNTED.
3. MOUNTING SURFACE BETWEEN 1.800 AND 1.725 DIAMETERS ON BOTH SIDES.

Housed BH02300 Series

MODEL	LENGTH
BH02300	1.991 (50.6)
BH02301	2.641 (67.1)
BH02302	3.291 (83.8)
BH02303	3.941 (100.1)

(5.2)
.205 ±.010 DIA. THRU. 4 PLCS.
EQ. SP. ON A 2.625 DIA. B.C.
(66.7)

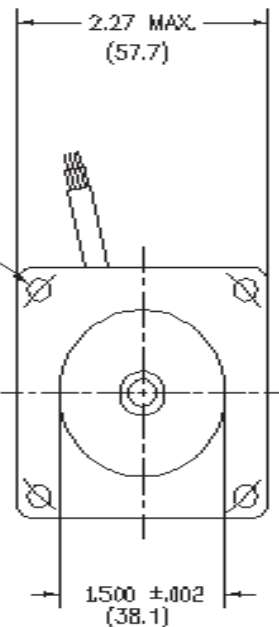

LEADWIRE - TEFLON COATED
TYPE "E" PER MIL-W-16878/4
12" MINIMUM LENGTH (305)
A) MOTOR: # 20 AWG. RED(A), WHT(B), BLK(C),
B) SENSOR: #24 AWG. BLU(+), BRN(A), ORG(B),
YEL(C), GRN(GRD)

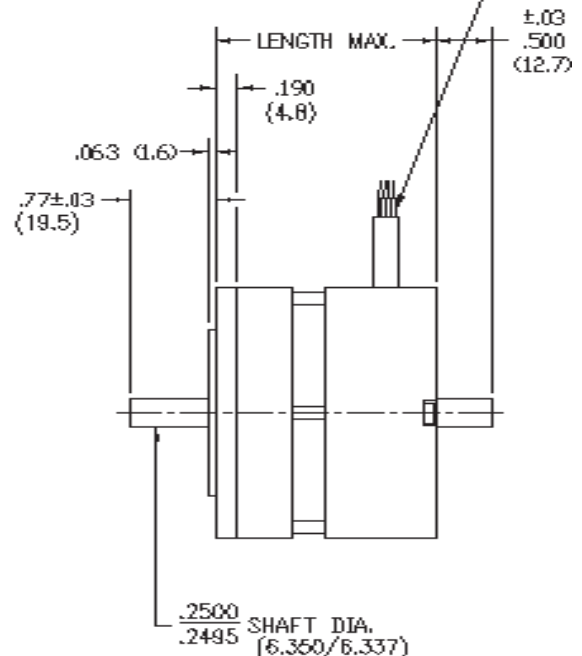

Hathaway
Emoteq, Inc

Emoteq, Inc (Main)
10002 E. 43rd St. So.
Tulsa, OK 74116
USA
Tel 800 433 3434
Fax 918 660 0207

Emoteq UK
Box 772,
Rottingdean BN2 8ND
United Kingdom
Tel 01273 390800
Fax 01273 301060

High Speed Series

BH02300 Series

Brushless DC Motors

Size Constants						
PARAMETER	SYMBOL	UNIT	BH02300	BH02301	BH02302	BH02303
Max Cont. Stall Torque	T_C	oz.in. Nm	14.3 0.101	29.8 0.21	43.1 0.30	56.1 0.39
Max Rated Torque, 25%	T_R	oz.in. Nm	161 1.14	340 2.40	522 3.69	699 4.94
Max Cont. Output Power	P_{out}	Watts	113	185	229	272
Motor Constant,	K_M	oz.in./V Nm/A	3.78 0.027	7.21 0.051	9.71 0.068	11.97 0.084
Electrical Time Constant	T_E	msec	0.32	0.53	0.63	0.71
Mechanical Time Constant	T_M	msec	8.48	4.55	3.65	3.22
Thermal Resistance	TPR	°C/Watt	4.18	3.55	3.16	2.81
Viscous Damping	F_1	oz.in./rpm Nm/rpm	3.2E-5 18	6.5E-5 4.6E-7	9.7E-5 6.9E-7	12.9E-5 9.1E-7
Max Cogging Torque	T_F	oz.in. Nm	1.56 0.011	2.07 0.0147	2.49 0.0176	2.84 0.0201

Mechanical Constants						
Frameless Motor Inertia	J_M	oz.in.s ² Kg.m ²	7.6E-4 5.4E-6	1.5E-3 1.1E-5	2.3E-3 1.6E-5	3.1E-3 2.2E-5
Frameless Motor Weight	Wt	oz Kg	8 0.22	14 0.40	20 0.57	26 0.74
Housed Motor Inertia	J_M	oz.in.s ² Kg.m ²	8.3E-4 5.9E-6	1.61E-3 1.1E-5	2.39E-3 1.7E-5	3.17E-3 2.2E-5
Housed Motor Weight	Wt	oz Kg	18 0.51	24 0.68	30 0.85	36 1.02
Number of Poles	-	-	4	4	4	4

Winding Constants														
Winding Designation	-	-	A	B	C	A	B	C	A	B	C	A	B	C
Design Voltage	V_p	Volts	24	43	130	24	43	130	24	43	130	24	43	130
Peak Torque	T_p	oz.in. Nm	85 0.60	106 0.75	133 0.94	175 1.23	245 1.73	340 2.40	172 1.22	309 2.18	522 3.69	263 1.85	472 3.33	650 4.58
Peak Current	I_p	Amperes	21.8	19.3	9.6	25.5	27.8	20.3	13.5	24.1	25.8	20.7	37.2	23.9
Torque Constant, ±10%	K_t	oz.in./A Nm/A	3.91 0.027	5.54 0.039	13.85 0.09	6.88 0.05	8.82 0.06	16.81 0.11	12.85 0.09	12.85 0.09	20.24 0.14	12.69 0.09	12.69 0.09	27.2 0.19
No Load Speed	S_{NL}	RPM Rad/s	8220 861	10410 1090	12600 1319	4690 491	6550 686	10420 1091	2500 262	4500 471	8650 906	2540 266	4560 478	6440 674
BEMF Constant, ±10%	K_B	V/KRPM V/rad/s	2.89 0.03	4.09 0.04	10.24 0.09	5.08 0.05	6.52 0.06	12.45 0.11	9.51 0.09	9.51 0.09	14.99 0.14	9.39 0.09	9.39 0.09	20.11 0.19
Terminal Resistance, ±12%	R_M	Ohms	1.10	2.23	13.5	0.94	1.55	5.65	1.78	1.78	4.54	1.16	1.16	5.44
Terminal Inductance, ±30%	L_M	mH	0.35	0.71	4.42	0.49	0.81	2.96	1.13	1.13	2.80	0.82	0.82	3.75

The graph plots Speed (RPM) and Speed (rad/sec) against Torque (oz. in.) for four motor models: BH02300, BH02301, BH02302, and BH02303. The top x-axis shows Torque in Nm (0 to 0.3). The left y-axis shows Speed in RPM (0 to 20000), and the right y-axis shows Speed in rad/sec (0 to 2000). Each curve represents the maximum continuous speed and torque for that model at a 115°C rise.

Continuous Duty Speed/Torque Curves for 115°C Rise

Speed/torque curves are provided as a guide to motor performance capability. The curves depict the maximum continuous speed and torque combinations based upon a winding temperature rise of 115°C. Typically the standard windings do not allow utilization of all of the performance envelope mainly because of the low K_t of higher speed windings. However, if required, standard motors can be driven to higher speeds if higher voltages are applied.

When it not possible to use a standard winding, a new winding can easily be designed.

High Speed Series

Brushless DC Motors

BH03400 Series

Frameless BH03400 Series

MODEL	"A" DIM.	"B" DIM.	"C" DIM.
BH03400	.500 (12.7)	.680 (17.3)	1.500 (38.1)
BH03401	1.150 (29.2)	1.330 (33.8)	2.150 (54.0)
BH03402	1.800 (45.7)	1.980 (50.3)	2.800 (71.1)
BH03403	2.450 (62.2)	2.630 (66.8)	3.450 (87.6)

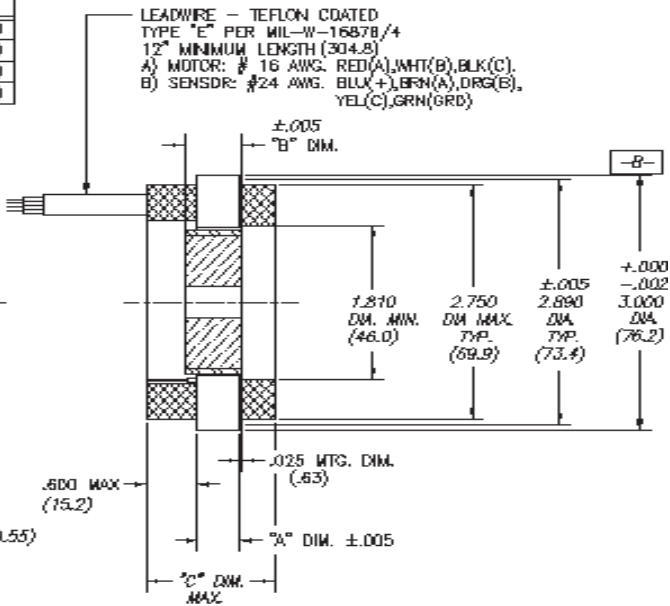
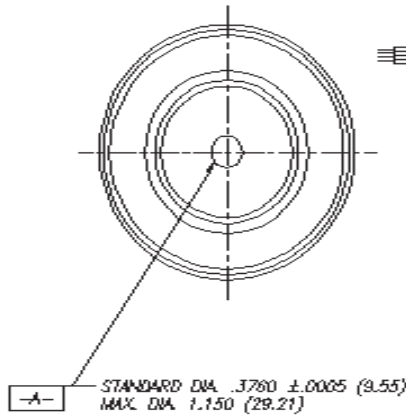

LEADWIRE - TEFLON COATED
 TYPE "E" PER MIL-W-16878/4
 12" MINIMUM LENGTH (304.8)
 A) MOTOR: # 16 AWG. RED(A), WHT(B), BLK(C).
 B) SENSOR: #24 AWG. BLU(+), BRN(A), ORG(B),
 YEL(C), GRN(GRD)

1. MOTOR SUPPLIED AS TWO SEPARATE COMPONENTS, MAGNET ASSY AND ARMATURE/SENSOR ASSY.
2. DIAMETERS -A- AND -B- TO BE CONCENTRIC WITHIN .002 WHEN MOUNTED.
3. MOUNTING SURFACE BETWEEN 3.000 AND 2.890 DIAMETERS ON BOTH SIDES.

Housed BH03400 Series

BH03400 SERIES HOUSED

MODEL	LENGTH
BH03400	2.300 (58.4)
BH03401	2.850 (74.3)
BH03402	3.600 (91.4)
BH03403	4.250 (108)

(5.66)
 .223 ±.010 DIA THRU. 4 PLCS.
 EQ. SP. ON A 3.875 DIA B.C.
 (98.4)

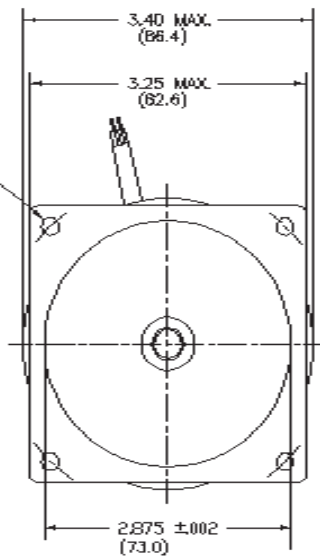

LEADWIRE - TEFLON COATED
 TYPE "E" PER MIL-W-16878/4
 12" MINIMUM LENGTH (304.8)
 A) MOTOR: # 16 AWG. RED(A), WHT(B), BLK(C).
 B) SENSOR: #24 AWG. BLU(+), BRN(A), ORG(B),
 YEL(C), GRN(GRD)

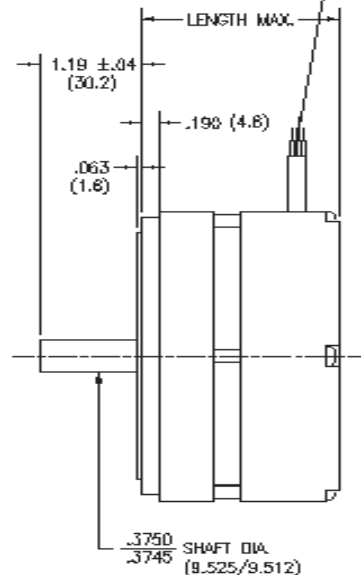

High Speed Series

Brushless DC Motors

BH03400 Series

Size Constants

PARAMETER	SYMBOL	UNIT	BH03400	BH03401	BH03402	BH03403
Max Cont. Stall Torque	T_C	oz.in.	47.5	106	165	217
			Nm	0.34	0.75	1.16
Max Rated Torque, 25%	T_R	oz.in.	293	704	1022	1304
			Nm	2.07	4.97	7.22
Max Cont. Output Power	P_{out}	Watts	359	540	670	783
			Motor Constant, K_M	oz.in./V	9.1	18.3
		Nm/A	0.064	0.129	0.189	0.239
Electrical Time Constant	T_E	msec	0.66	1.19	1.63	1.97
Mechanical Time Constant	T_M	msec	11.15	5.44	3.78	3.05
Thermal Resistance	TPR	°C/Watt	2.44	2.00	1.84	1.65
Viscous Damping	F_V	oz.in./rpm	1.12E-4	2.41E-4	3.69E-4	4.97E-4
			Nm/rpm	8.0E-7	1.7E-6	2.6E-6
Max Cogging Torque	T_F	oz.in.	2.83	4.07	5.01	5.78
			Nm	0.020	0.028	0.035

Mechanical Constants

Frameless Motor Inertia	J_M	oz.in.s ²	6.3E-3	1.3E-2	1.9E-2	2.6E-2
		Kg.m ²	4.4E-5	9.1E-5	1.3E-4	1.8E-4
Frameless Motor Weight	Wt	oz	19	35	50	65
		Kg	0.53	0.99	1.42	1.84
Housed Motor Inertia	J_M	oz.in.s ²	6.4E-3	1.3E-2	2.0E-2	2.7E-2
		Kg.m ²	4.5E-5	9.2E-5	1.4E-4	1.9E-4
Housed Motor Weight	Wt	oz	37	53	69	85
		Kg	1.05	1.50	1.95	2.4
Number of Poles	-	-	4	4	4	4

Winding Constants

Winding Designation	-	-	A			B			C			A			B			C		
			24	43	130	24	43	130	24	43	130	24	43	130	24	43	130	24	43	130
Design Voltage	V_P	Volts	24	43	130	24	43	130	24	43	130	24	43	130	24	43	130	24	43	130
Peak Torque	T_P	oz.in.	155	277	293	365	655	704	815	832	1022	1253	769	1304	8.85	5.43	9.2	8.85	5.43	9.2
Peak Current	I_P	Amperes	12.2	21.9	14.3	16.9	28.6	18.2	39.7	22.3	14.8	57.4	11.7	18.4	57.4	11.7	18.4	57.4	11.7	18.4
Torque Constant, ±10%	K_T	oz.in./A	12.65	12.65	20.43	21.70	22.91	38.58	20.53	37.32	69.04	21.86	65.57	70.66	21.86	65.57	70.66	21.86	65.57	70.66
		Nm/A	0.089	0.089	0.144	0.153	0.161	0.272	0.144	0.263	0.487	0.154	0.463	0.499	0.154	0.463	0.499	0.154	0.463	0.499
No Load Speed	S_{NL}	RPM	2540	4570	8570	1490	2530	4540	1570	1550	2540	1480	880	2480	1480	880	2480	1480	880	2480
		Rad/s	266	479	897	156	265	475	164	162	266	155	92	260	155	92	260	155	92	260
BEMF Constant, ±10%	K_B	V/KRPM	9.35	9.35	15.11	16.05	16.94	28.53	15.18	27.60	51.05	16.16	48.48	52.25	16.16	48.48	52.25	16.16	48.48	52.25
		V/rad/s	0.089	0.089	0.144	0.153	0.161	0.272	0.144	0.263	0.487	0.154	0.463	0.499	0.154	0.463	0.499	0.154	0.463	0.499
Terminal Resistance, ±12%	R_M	Ohms	1.96	1.96	5.02	1.42	1.50	4.49	0.60	1.93	6.70	0.42	3.66	4.31	0.42	3.66	4.31	0.42	3.66	4.31
Terminal Inductance, ±30%	L_M	mH	1.29	1.29	3.38	1.69	1.88	5.36	0.96	3.19	10.92	0.80	7.23	8.39	0.80	7.23	8.39	0.80	7.23	8.39

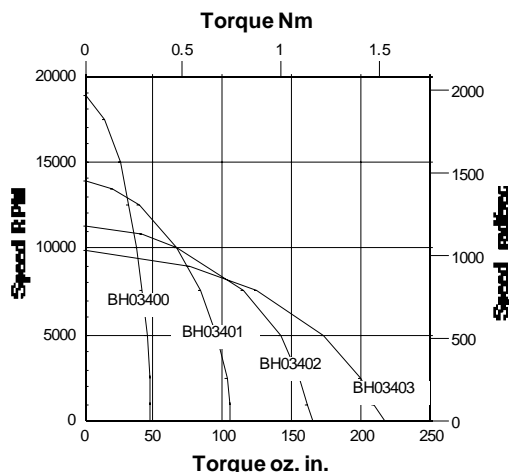

Continuous Duty Speed/Torque Curves for 115°C Rise

Speed/torque curves are provided as a guide to motor performance capability. The curves depict the maximum continuous speed and torque combinations based upon a winding temperature rise of 115°C. Typically the standard windings do not allow utilization of all of the performance envelope mainly because of the low K_T of higher speed windings. However, if required, standard motors can be driven to higher speeds if higher voltages are applied.

When it not possible to use a standard winding, a new winding can easily be designed.

High Speed Series

Brushless DC Motors

Example Designs

Example Designs of High Speed Brushless Motors

The motors whose specifications are published on these two pages, are used in the following applications (in no particular order):

- Printed circuit board drilling spindles
- Laser scanning heads
- Image acquisition and reproduction
- High speed machining heads
- Semiconductor deposition and cleaning systems
- Silicon wafer slicing equipment
- Optical glass grinding

The loadpoint curves published below are provided to serve as a guide to motor capabilities. Details of the output powers of the motors is tabulated on the opposite page.

Application and Design Engineering

Generally, designing motors for high speed applications requires consideration of all parameters of the application including the loadpoint (speed and torque or output power), power supply, the mechanical constraints, and the environmental conditions.

Emoteq is organized with applications and design engineers who can assist in defining a motor to suit your requirements. Further, we can quickly deliver motors to meet your needs through our special products group.

Once prototype testing and production design release has been finalized, then our standard product manufacturing group takes over to provide cost effective motors and assure uniformly high quality.

Loadpoint curves for design examples

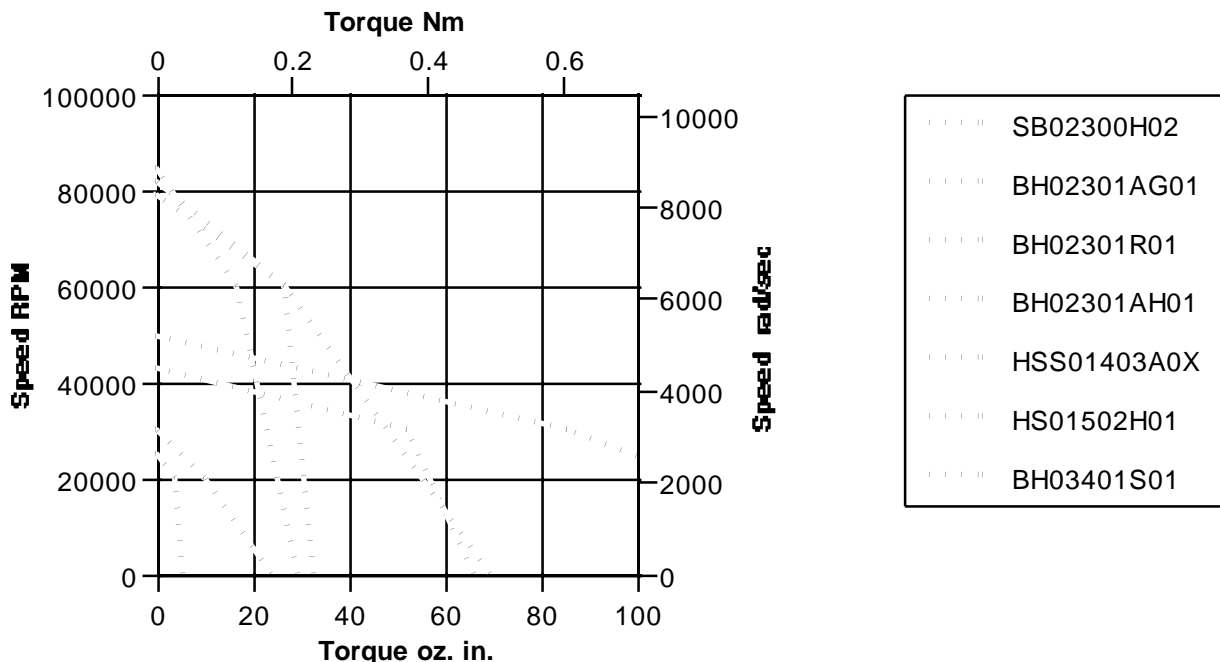

High Speed Series

Brushless DC Motors

Example Designs

Size Constants									
Parameter	Symbol	Unit	SB02300	BH02301	BH02301	BH02301	HS01502	HSS01403	BH03401
Max Cont. Stall Torque	T_C	oz.in. Nm	5.9 0.042	24.1 0.170	66.5 0.470	69.8 0.493	29.6 0.209	33.0 0.233	253 1.79
Max Rated Torque, 25%	T_R	oz.in. Nm	76.8 0.543	234 1.65	351 2.48	237 1.67	113 0.799	225 1.594	535 3.784
Motor Constant,	K_M	oz.in./V Nm/V	1.96 0.014	5.70 0.040	7.06 0.050	5.34 0.038	3.42 0.024	4.50 0.032	19.49 0.138
Electrical Time Constant	T_E	msec	0.236	0.616	0.719	0.529	0.536	0.316	2.527
Mechanical Time Constant	T_M	msec	8.58	4.98	3.746	5.393	2.456	2.662	4.178
Thermal Resistance	TPR	°C/Watt	8.5	3.55	0.74	0.44	1.00	1.12	0.40
Viscous Damping	F_V	oz.in./rpm Nm/rpm	2.0E-5 1.5E-7	4.8E-5 3.4E-7	6.7E-5 4.7E-7	4.7E-5 3.3E-7	1.6E-5 1.1E-7	1.4E-5 1.0E-7	2.6E-4 1.9E-6
Max Cogging Torque	T_F	oz.in. Nm	0.50 0.003	2.07 0.015	2.07 0.015	2.07 0.015	1.80 0.013	2.0 0.014	4.07 0.029

Mechanical Constants									
Stator Diameter	D	in mm	1.800 45.720	1.800 45.720	1.800 45.720	1.800 45.720	1.488 37.795	1.400 35.560	3.000 76.200
Stator Length	L	in mm	0.250 6.35	1.150 29.21	1.150 29.21	1.150 29.21	1.050 26.67	1.450 36.83	1.150 29.21
Length over coils	OL	in mm	0.870 22.09	1.77 44.95	1.77 44.95	1.77 44.95	1.90 48.26	2.16 54.91	2.15 54.61
Frameless Motor Inertia	J_M	oz.in.s ² Kg.m ²	2.3E-4 1.6E-6	1.1E-3 8.0E-6	1.3E-3 9.3E-6	1.1E-3 7.7E-6	2.0E-4 1.4E-6	3.8E-4 2.7E-6	1.1E-2 7.9E-5
Frameless Motor Weight	Wt	oz Kg	3.0 0.09	10.9 0.31	11.1 0.32	10.7 0.304	6.5 0.185	8.0 0.228	33.9 0.962
Number of Poles	-	n	4	4	4	4	4	4	4

Winding Constants									
Winding Designation	-	-	H02	AG01	R01	AH01	H01	A0X	S01
Design Voltage	V_p	Volts	21.2	110	180	300	120	150	300
Peak Torque	T_p	oz.in. Nm	70 0.49	234 1.65	351 2.48	237 1.67	113 0.79	225 1.59	535 3.78
Peak Current	I_p	Amperes	56.2	47.3	61.3	43.2	57.7	87.2	64.7
Torque Constant, ±10%	K_T	oz.in./A Nm/A	1.16 0.008	4.95 0.035	5.73 0.040	5.00 0.035	1.92 0.014	2.58 0.018	8.27 0.058
No Load Speed	S_{NL}	RPM Rad/s	24675 2584	30003 3149	42458 4446	81116 8494	84433 8841	78383 8208	49039 5135
BEMF Constant, ±10%	K_B	V/KRPM V/rad/s	0.85 0.008	3.66 0.035	4.24 0.040	3.69 0.035	1.42 0.014	1.91 0.018	6.118 0.058
Terminal Resistance, ±12%	R_M	Ohms	0.352	0.756	0.658	0.875	0.315	0.330	0.180
Terminal Inductance, ±30%	L_M	mH	0.083	0.465	0.473	0.463	0.169	0.104	0.455
Loadpoint data									
Speed	S	RPM	20000	20000	30000	60000	60000	60000	30000
Torque	T	oz.in. Nm	3.9 0.028	10.2 0.072	52.7 0.372	27.2 0.192	17.0 0.121	27.0 0.191	85.7 0.606
Output Power	P	Watts	57.7	151.5	1168	1208	757	1200	1903
Temp Rise	T_{rise}	°C	118	89	115	73	87	113	96
Voltage	$V_{terminal}$	VDC	21.2	110	180	300	120	150	300
DC link current	I	Amps	3.37	1.60	7.35	4.5	7.0	8.7	7.1
Efficiency	-	%	80.6	85.7	88.2	87.8	89.7	92.2	88.7
Cooling	-	-	still air	still air	water	water	water	water	water

Brushless DC Motors

Size Constants

These parameters are dependent upon the size and shape of the motor but are largely independent of the winding used. However, special designs incorporating different lamination and magnet materials as well as design modifications such as increased magnetic air gaps can change these parameters. In such instances, a specific set of design data will be provided.

Maximum Continuous Stall Torque (T_C) is the amount of torque produced at zero speed which results in a 75°C rise in temperature. Generally, the highest operating temperature that should be allowed is 150°C and is a combination of the ambient temperature and the temperature rise for a given operating condition.

Maximum Rated Torque (T_R) is the amount of torque that the motor can produce without danger of demagnetizing the rotor. This torque is only available for short durations. Also, it may not be possible to produce the Maximum Rated Torque because of limitations of voltage and current (see Peak Torque).

Motor Constant (K_M) is the ratio of the peak torque to the square root of the input power at stall with 25°C ambient temperature. This ratio is useful during the initial selection of a motor because it indicates the ability of the motor to convert electrical power into torque.

$$K_M = T_P (\text{Peak Torque}) / \sqrt{P_P (\text{Peak Input Power})}$$

or

$$K_M = K_T (\text{Torque Constant}) / \sqrt{R_M (\text{Term. Resistance})}$$

Electrical Time Constant (T_E) is the ratio of inductance L_M in Henries, to the resistance R_M in Ohms. This is the inductance and resistance as measured across any two phases in a delta or wye configuration.

$$T_E = L_M / R_M$$

Mechanical Time Constant (T_M) is the time required to reach 63.2% of the motors maximum speed after the application of constant DC voltage through the commutation electronics, ignoring friction, windage, and core losses.

$$T_M = J_M * R_M / K_T * K_B$$

Thermal Resistance (TPR) correlates winding temperature rise to the average power dissipated in the stator winding. The published TPR assumes that a housed motor is mounted to an aluminum heatsink of specific dimensions. Additional cooling from forced air, water jacketing, or increased heatsinking decreases the motor Thermal Resistance allowing higher power outputs than the published data.

Viscous Damping (F) represents the losses in the motor which are proportional to speed with an infinite source impedance. Such losses include windage, friction, and eddy currents.

Maximum Cogging Torque (T_C) is principally the static friction torque felt as the motor is rotated at low speed. The published value does not include the bearing friction of a housed motor.

Winding Constants

The winding constants are the parameters that vary with the number of wire turns per coil and the wire size. These parameters are collected under an alphabetical winding designation. A single frame size and length of motor will have several different windings. Special windings receive new designations in the sequence by which they are designed and released to production.

Design Voltage (V_p) is the nominal voltage required to produce the peak torque when the rotor speed is zero and the winding temperature is 25°C. As such, V_p is the product of I_p and R_M . At any temperature greater than 25°C, the required voltage to produce peak torque increases due to the increase in winding resistance. The design voltage is not a limit but a reference point for the data.

Peak Torque (T_p) is the nominal value of developed torque with the rated current I_p applied to the windings. For each winding specified the product of peak current (I_p) and nominal torque sensitivity (K_T) gives T_p unless the maximum rated torque (T_R) is reached.

Peak Current (I_p) is the rated current used to obtain the nominal peak torque from the motor with nominal torque sensitivity (K_T). I_p is generally the design voltage divided by the terminal resistance (R_M).

High Speed Series

Connection Diagrams

Brushless DC Motors

Torque Sensitivity (K_T) is the ratio of the developed torque to the applied current for a specific winding. K_T is related to the BEMF Constant K_B .

No Load Speed (S_{NL}) is the theoretical no load speed of the motor with the design voltage applied.

BEMF Constant (K_B) is the ratio of voltage generated in the winding to the speed of the rotor. K_B is proportional to K_T .

Terminal Resistance (R_M) is the winding resistance measured between any two leads of the winding in either a delta or wye configuration at 25°C.

Terminal Inductance (L_M) is the winding inductance measured between any two leads of the winding in either delta or wye configuration at 25°C.

Mechanical Data

Rotor inertia (J_M) is the moment of inertia of the rotor about its axis of rotation.

Motor Weight (W) is the weight of the standard motor.

Number of Poles (N_p) is the number of permanent magnet poles of the rotor. For the standard BH Series motors this is four poles (two pole pairs).

Speed-Torque Curves

BH Series curves are for the standard catalog designs. The curves are based upon a 115°C rise over the ambient temperature.

The temperature rise of the example motors for a particular loadpoint is given in the tabulated data and differs from model to model.

Motor Connections and Commutation Logic

MOTOR EXCITATION SEQUENCE AND SENSOR OUTPUT LOGIC FOR CW ROTATION VIEWING LEADWIRE END.

EXCITATION STEP		1	2	3	4	5	6	1
MOTOR LEADS	(RED) A	+	+	-	-	+	+	
	(WHT) B	-	+	+	-	-	+	
	(BLK) C	-	-	+	+	-	-	
SENSOR OUTPUTS	(BRN) A	1	1	0	0	1	1	
	(ORG) B	0	1	1	1	0	0	
	(YEL) C	0	0	0	1	1	1	

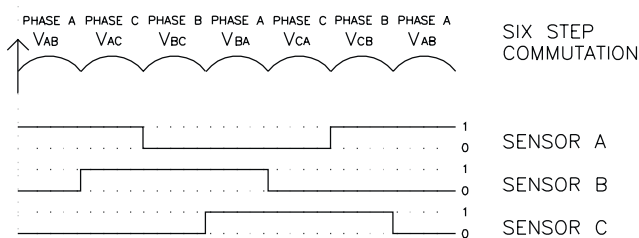
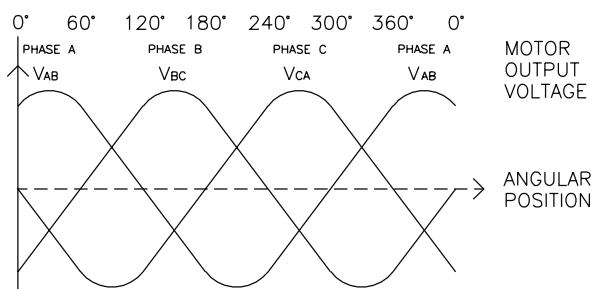

HALL EFFECT CONNECTION DIAGRAM

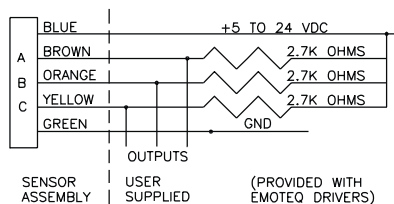

High Speed Series

Brushless DC Motors

**Sales
Offices**

Hathaway Corporation

Emoteq, Inc

Factory Direct Sales Offices

Emoteq, Inc (Main)

10002 E. 43rd St. So.
Tulsa, OK 74146
USA
Representative Tel 918 627 1845
Fax 918 660 0207

Emoteq UK

Box 772,
Rottingdean BN2 8ND
United Kingdom
Tel 01273 390800
Fax 01273 301060

International Representatives

Germany

IME GmbH
Brugger-Str. 8
78628 Rottweil
Tel (49) 0741 174290
Fax (49) 0741 22060

Singapore

Plant & Mill Supplies Ltd.
4 Loyang Street,
Loyang Ind. Estate,
Singapore 508839
Tel (65) 542 4211
Fax (65) 542 1318

All data subject to specific tolerances. All critical design data should be verified before final design. Errors due to rounding may exist in the data. Emoteq reserves the right to make changes without notice.

Hathaway
Emoteq, Inc

Emoteq, Inc

10002 E. 43rd St. So.
Tulsa, Oklahoma 74146
Rep Tel 800 433 3434
Fax 918 660 0207